

Tamper

40 lb class

TEX 640

Safety and operators instructions



Specifications

Net Weight	17 kg	38.5 lbs
Length	1226 mm	48.25 in
Bore	38 mm	1.5 in
Stroke	140 mm	5.5 in
Blows per minute	1450	1450
Chuck Sizes		804 taper
Air Inlet (NPT)	13 mm	1/2 in
Air Consumption*	1.1 m ³ /m	38.5 cfm

*ESTIMATED

Contents

ENGLISH.....4

ENGLISH

Contents

Introduction 5

About the Safety and operating instructions 5

Safety instructions 6

- Safety signal words 6
- Personal precautions and qualifications 6
- Installation, precautions 6
- Operation, precautions 7
- Maintenance, precautions 10
- Storage, precautions 10

Overview 11

- Design and function 11
- Main parts 11
- Labels 11

Installation 12

- Hoses and connections 12
- Methods to prevent freezing 12
- Connecting a water separator 13
- Lubrication 13
- Fitting and removing the butt 13

Operation 14

- Start and stop 14
- Operating 14
- When taking a break 14

Maintenance 14

- Every day 15
- Periodic maintenance 15
- Tightening torques 15
- Adjustment of the piston rod seal 16

Troubleshooting 16

Storage 17

Disposal 17

Introduction

Thank you for choosing a product from Atlas Copco. Since 1873, we have been committed to finding new and better ways of fulfilling our customers' needs. Through the years, we have developed innovative and ergonomic product designs that have helped customers improve and rationalize their daily work.

Atlas Copco has a strong global sales and service network, consisting of customer centers and distributors worldwide. Our experts are highly trained professionals with extensive product knowledge and application experience. In all corners of the world, we can offer product support and expertise to ensure that our customers can work at maximum efficiency at all times.

For more information please visit: www.atlascopco.com

About the Safety and Operating Instructions

The aim of the instructions is to provide you with knowledge of how to use the pneumatic breaker in an efficient, safe way. The instructions also give you advice and tell you how to perform regular maintenance on the pneumatic breaker.

Before using the pneumatic breaker for the first time you must read these instructions carefully and understand all of them.

Safety instructions

To reduce the risk of serious injury or death to yourself or others, read and understand the Safety and operating instruction before installing, operating, repairing, maintaining, or changing accessories on the machine.

Post this Safety and operating instruction at work locations, provide copies to employees, and make sure that everyone reads the Safety and operating instruction before operating or servicing the machine.

In addition, the operator or the operator's employer must assess the specific risks that may be present as a result of each use of the machine.

Safety signal words

The safety signal words Danger, Warning and Caution have the following meanings:

DANGER	Indicates a hazardous situation which, if not avoided, will result in death or serious injury.
WARNING	Indicates a hazardous situation which, if not avoided, could result in death or serious injury.
CAUTION	Indicates a hazardous situation which, if not avoided, could result in minor or moderate injury.

Personal precautions and qualifications

Only qualified and trained persons may operate or maintain the machine. They must be physically able to handle the bulk, weight, and power of the tool. Always use your common sense and good judgement.

Personal protective equipment

Always use approved protective equipment. Operators and all other persons in the working area must wear protective equipment, including at a minimum:

- > Protective helmet
- > Hearing protection
- > Impact resistant eye protection with side protection
- > Respiratory protection when appropriate
- > Protective gloves

- > Proper protective boots
- > Appropriate work overall or similar clothing (not loose-fitting) that covers your arms and legs.

Drugs, alcohol or medication

▲ **WARNING** Drugs, alcohol or medication

Drugs, alcohol or medication may impair your judgment and powers of concentration. Poor reactions and incorrect assessments can lead to severe accidents or death.

- ▶ Never use the machine when you are tired or under the influence of drugs, alcohol or medication.
- ▶ No person who is under the influence of drugs, alcohol or medication may operate the machine.

Installation, precautions

▲ **DANGER** Whipping air hose

A compressed air hose that comes loose can lash around and cause personal injury or death. To reduce this risk:

- ▶ Check that the compressed air hose and the connections are not damaged, replace if necessary.
- ▶ Check that all compressed air connections are properly attached.
- ▶ Never carry a pneumatic machine by the air hose.
- ▶ Never attempt to disconnect a compressed air hose that is pressurized. First switch off the compressed air at the compressor and then bleed the machine by activating the start and stop device.
- ▶ Never point a compressed air hose at yourself or anyone else. To avoid the risk of getting injured, never use compressed air to blow for example dust, dirt etc. from your clothes.
- ▶ Do not use quick disconnect couplings at tool inlet. Use hardened steel (or material with comparable shock resistance) threaded hose fittings.
- ▶ Whenever universal twist couplings (claw couplings) are used, we recommend that lock pins are installed and whipcheck safety cables are used to safeguard against possible hose to tool and hose to hose connection failure.

▲ WARNING Ejected butt

If the lock nut on the machine is not tightened securely, the butt can be ejected with force, which can cause personal injury.

- ▶ Never start the machine while changing the butt.
- ▶ Before changing the butt or accessories, stop the machine, switch off the power supply and bleed the machine by activating the start and stop device.
- ▶ Never point the butt end of the machine at yourself or anyone else.
- ▶ Make sure that the butt is fully fitted and the lock nut is tightened securely before the machine is started.

Operation, precautions

▲ DANGER Explosion hazard

If a butt comes into contact with explosives or explosive gases, an explosion could occur. When working on certain materials and when using certain materials in machine parts, sparks and ignition can occur. Explosions will lead to severe injuries or death.

- ▶ Never operate the machine in any explosive environment.
- ▶ Never use the machine near flammable materials, fumes, or dust.
- ▶ Make sure that there are no undetected sources of gas or explosives.

▲ WARNING Unexpected movements

The tamper is exposed to forces when in use. The forces can cause sudden and unexpected movements that can cause injuries. Furthermore, losing your balance or slipping may cause injury.

- ▶ Make sure that you always keep a stable position with your feet as far apart as your shoulder width, and keeping a balanced body weight.
- ▶ Always inspect the equipment prior to use. Never use the equipment if you suspect that it is damaged.
- ▶ Make sure that the handle grip is clean and free of grease and oil.
- ▶ Keep your feet away from the butt.
- ▶ Stand firmly and always hold on to the machine with a firm grip.
- ▶ Never start the machine when it is lying on the ground.

- ▶ Never strike or abuse the equipment.
- ▶ Check regularly for wear on the butt, and check whether there are any signs of damage or visible cracks.
- ▶ Pay attention and look at what you are doing.

▲ WARNING Dust and fume hazard

Dusts and/or fumes generated or dispersed when using the machine may cause serious and permanent respiratory disease, illness, or other bodily injury (for example, silicosis or other irreversible lung disease that can be fatal, cancer, birth defects, and/or skin inflammation).

Some dusts and fumes created by drilling, breaking, hammering, sawing, grinding and other construction activities contain substances known to the State of California and other authorities to cause respiratory disease, cancer, birth defects, or other reproductive harm. Some examples of such substances are:

- > Crystalline silica, cement, and other masonry products.
- > Arsenic and chromium from chemically-treated rubber.
- > Lead from lead-based paints.

Dust and fumes in the air can be invisible to the naked eye, so do not rely on eye sight to determine if there is dust or fumes in the air.

To reduce the risk of exposure to dust and fumes, do all of the following:

- ▶ Perform site-specific risk assessment. The risk assessment should include dust and fumes created by the use of the machine and the potential for disturbing existing dust.
- ▶ Use proper engineering controls to minimize the amount of dust and fumes in the air and to minimize build-up on equipment, surfaces, clothing, and body parts. Examples of controls include: exhaust ventilation and dust collection systems, water sprays, and wet drilling. Control dusts and fumes at the source where possible. Make sure that controls are properly installed, maintained and correctly used.
- ▶ Wear, maintain and correctly use respiratory protection as instructed by your employer and as required by occupational health and safety regulations. The respiratory protection must be effective for the type of substance at issue (and if applicable, approved by relevant governmental authority).
- ▶ Work in a well ventilated area.

- ▶ If the machine has an exhaust, direct the exhaust so as to reduce disturbance of dust in a dust filled environment.
- ▶ Operate and maintain the machine as recommended in the operating and safety instructions
- ▶ Select, maintain and replace consumables/ inserted tools/ other accessory as recommended in the operating and safety instructions. Incorrect selection or lack of maintenance of consumables/ inserted tools/ other accessories may cause an unnecessary increase in dust or fumes.
- ▶ Wear washable or disposable protective clothes at the worksite, and shower and change into clean clothes before leaving the worksite to reduce exposure of dust and fumes to yourself, other persons, cars, homes, and other areas.
- ▶ Avoid eating, drinking, and using tobacco products in areas where there is dust or fumes.
- ▶ Wash your hands and face thoroughly as soon as possible upon leaving the exposure area, and always before eating, drinking, using tobacco products, or making contact with other persons.
- ▶ Comply with all applicable laws and regulations, including occupational health and safety regulations.
- ▶ Participate in air monitoring, medical examination programs, and health and safety training programs provided by your employer or trade organizations and in accordance with occupational health and safety regulations and recommendations. Consult with physicians experienced with relevant occupational medicine.
- ▶ Work with your employer and trade organization to reduce dust and fume exposure at the worksite and to reduce the risks. Effective health and safety programs, policies and procedures for protecting workers and others against harmful exposure to dust and fumes should be established and implemented based on advice from health and safety experts. Consult with experts.

▲ WARNING Projectiles

Failure of the work piece, of accessories, or even of the machine itself may generate high velocity projectiles. During operating, splinters or other particles from the working material may become projectiles and cause personal injury by striking the operator or other persons. To reduce these risk:

- ▶ Use approved personal protective equipment and safety helmet, including impact resistant eye protection with side protection.
- ▶ Make sure that no unauthorised persons trespass into the working zone.
- ▶ Keep the workplace free from foreign objects.
- ▶ Ensure that the work piece is securely fixed.

▲ WARNING Slipping, tripping and falling hazards

There is a risk of slipping or tripping or falling, for example tripping on the hoses or on other objects. Slipping or tripping or falling can cause injury. To reduce this risk:

- ▶ Always make sure that no hose or other object is in your way or in any other person's way.
- ▶ Always make sure you are in a stable position with your feet as far apart as your shoulders width and keeping a balanced body weight.

▲ WARNING Motion hazards

When using the machine to perform work-related activities, you may experience discomfort in the hands, arms, shoulders, neck, or other parts of the body.

- ▶ Adopt a comfortable posture whilst maintaining secure footing and avoiding awkward off-balanced postures.
- ▶ Changing posture during extended tasks may help avoid discomfort and fatigue.
- ▶ In case of persistent or recurring symptoms, consult a qualified health professional.

▲ WARNING Long piston stroke hazard

The butt is directly connected to the piston and will immediately start to move up and down when the start and stop device is activated, this can cause personal injury.

- ▶ Pay attention and look at what you are doing when starting the machine.

▲ WARNING Vibration hazards

Normal and proper use of the machine exposes the operator to vibration. Regular and frequent exposure to vibration may cause, contribute to, or aggravate injury or disorders to the operator's fingers, hands, wrists, arms, shoulders and/or nerves and blood supply or other body parts, including debilitating and/or permanent injuries or disorders that may develop gradually over periods of weeks, months, or years. Such injuries or disorders may include damage to the blood circulatory system, damage to the nervous system, damage to joints, and possibly damage to other body structures.

If numbness, persistent recurring discomfort, burning sensation, stiffness, throbbing, tingling, pain, clumsiness, weakened grip, whitening of the skin, or other symptoms occur at any time, when operating the machine or when not operating the machine, stop operating the machine, tell your employer and seek medical attention. Continued use of the machine after the occurrence of any such symptom may increase the risk of symptoms becoming more severe and/or permanent.

Operate and maintain the machine as recommended in these instructions, to prevent an unnecessary increase in vibration.

The following may help to reduce exposure to vibration for the operator:

- ▶ Let the tool do the job. Use a minimum hand grip consistent with proper control and safe operation.
- ▶ If the machine has vibration absorbing handles, keep them in a central position, avoid pressing the handles into the end stops.
- ▶ When the percussion mechanism is activated, the only body contact with the machine you should have are your hands on the handle or handles. Avoid any other contact, for example supporting any part of the body against the machine or leaning onto the machine trying to increase the feed force. It is also important not to keep the start and stop device engaged while extracting the tool from the broken work surface.
- ▶ Immediately stop working if the machine suddenly starts to vibrate strongly. Before resuming the work, find and remove the cause of the increased vibrations.
- ▶ Participate in health surveillance or monitoring, medical exams and training programs offered by your employer and when required by law.
- ▶ When working in cold conditions wear warm clothing and keep hands warm and dry.

See the "Noise and vibration declaration statement" for the machine, including the declared vibration values. This information can be found at the end of these Safety and operating instructions.

- ◆ Comply with the recommended air-pressure when operating the machine. Either higher or lower air-pressure has the potential of resulting in higher levels of vibration.

▲ DANGER Electrical hazard

The machine is not electrically insulated. If the machine comes into contact with electricity, serious injuries or death may result.

- ▶ Never operate the machine near any electric wire or other source of electricity.
- ▶ Make sure that there are no concealed wires or other sources of electricity in the working area.

▲ WARNING Concealed object hazard

During operating, concealed wires and pipes constitute a danger that can result in serious injury.

- ▶ Check the composition of the material before operating.
- ▶ Watch out for concealed cables and pipes for example electricity, telephone, water, gas and sewage lines etc.
- ▶ If the butt seems to have hit a concealed object, switch off the machine immediately.
- ▶ Make sure that there is no danger before continuing.

▲ WARNING Involuntary start

Involuntary start of the machine may cause injury.

- ▶ Keep your hands away from the start and stop device until you are ready to start the machine.
- ▶ Learn how the machine is switched off in the event of an emergency.
- ▶ Release the start and stop device immediately in all cases of power supply interruption.
- ▶ Before undertaking any kind of maintenance, installation, inspection or cleaning; switch off the air supply, bleed the machine by activating the start and stop device and disconnect the machine from the power source.

▲ WARNING Noise hazard

High noise levels can cause permanent and disabling hearing loss and other problems such as tinnitus (ringing, buzzing, whistling, or humming in the ears). To reduce risks and prevent an unnecessary increase in noise levels:

- ▶ Risk assessment of these hazards and implementation of appropriate controls is essential.
- ▶ Operate and maintain the machine as recommended in these instructions.
- ▶ Select, maintain and replace the butt as recommended in these instructions.
- ▶ If the machine has a muffler, check that it is in place and in good working condition.
- ▶ Always use hearing protection.

Maintenance, precautions

▲ WARNING Machine modification

Any machine modification may result in bodily injuries to yourself or others.

- ▶ Never modify the machine. Modified machines are not covered by warranty or product liability.
- ▶ Always use original parts, butts, and accessories.
- ▶ Change damaged parts immediately.
- ▶ Replace worn components in good time.

Storage, precautions

- ◆ Keep the machine and tools in a safe place, out of the reach of children and locked up.

Overview

To reduce the risk of serious injury or death to yourself or others, read the Safety instructions section found on the previous pages of this manual before operating the machine.

Design and function

Tex 640 Round & Pole butts are pneumatic tampers designed to effectively compact soil around foundations and other structures and for compacting back fill in trenches. Tex 640 is designed for light to medium applications and Tex 640 is designed for heavier applications. The pneumatic tampers are designed for vertical downward use. No other use is permitted.

Recommended butts are listed in the spare parts list.

Main parts

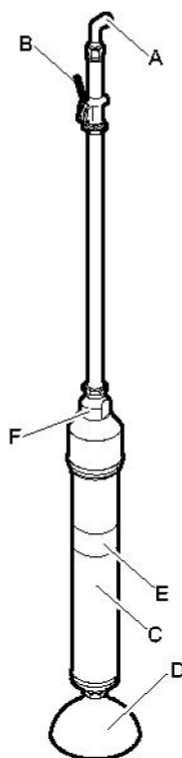
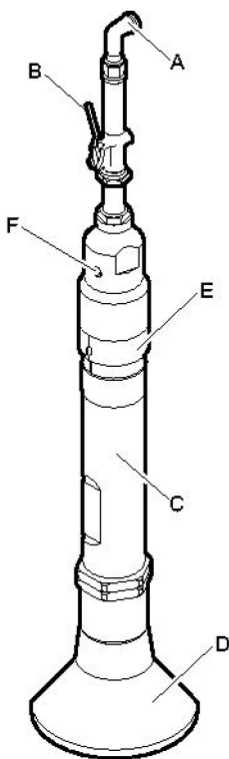

- A. Air inlet
- B. Start and stop device
- C. Cylinder
- D. Butt
- E. Exhaust deflector
- F. Integrated oiler

Labels

The machine is fitted with labels containing important information about personal safety and machine maintenance. The labels must be in such condition that they are easy to read. New labels can be ordered from the spare parts list.

Data plate

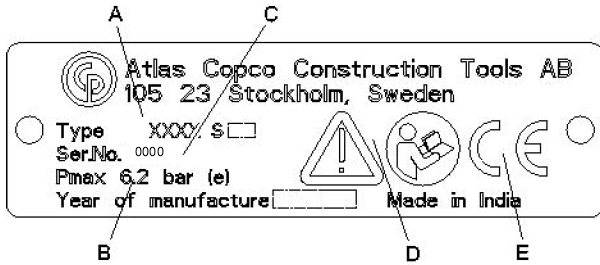

- A. Machine type
- B. Maximum permitted compressed air pressure
- C. Serial number
- D. The warning symbol together with the book symbol means that the user must read the safety and operating instructions before the machine is used for the first time.
- E. The CE symbol means that the machine is EC-approved. See the EC declaration which is delivered with the machine for more information. If the CE symbol is missing, it means that the machine is not EC-approved.

Noise level label

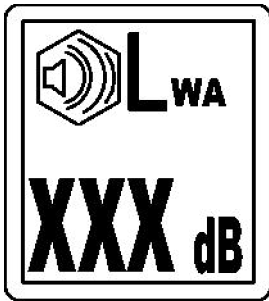

The label indicates the guaranteed noise level corresponding to EC-directive 2000/14/EC. See "Technical data" for accurate noise level.

Safety label

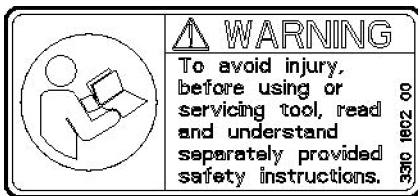

To avoid injury, before using or servicing tool, read and understand separately provided safety instructions.

Installation

Hoses and connections

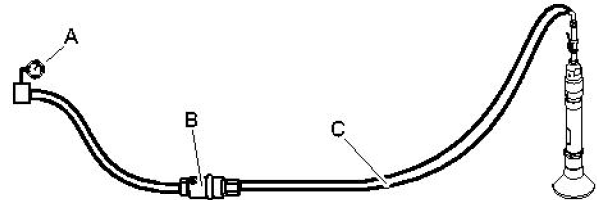

- A. Compressed air source
 - B. Water separator (optional)
 - C. Max. 10 feet (3 meter) compressed air hose between the water separator and the machine.
- ♦ Check that you are using the correct recommended operating pressure, 87 psig (6 bar (e)).
 - ♦ The maximum permissible air pressure, 90 psig (6.2 bar (e)), must not be exceeded.
 - ♦ Blow any impurities out of the compressed air hose before connecting it to the machine.
 - ♦ Select the correct dimension and length for the compressed air hose. For hose lengths up to 100 feet (30 meters), a hose with a minimum internal diameter of $\frac{3}{4}$ in. (19 mm) should be used. If the hose length is between 100 and 330 feet (30 and 100 meters), a hose with a minimum internal diameter of 1 in. (25 mm) should be used.

Methods to prevent freezing

Ice formation in the machine can occur when the ambient air temperature is 32-50 °F (0-10 °C) and the relative humidity is high.

The following actions can be taken to counteract the risk of ice formation:

- ♦ Use AC Airolene Plus Tool Oil as a lubricant. CP Airolene Plus Tool Oil counteracts freezing.
- ♦ Use a water separator.

Connecting a water separator

The length of the air hose between the compressor and the water separator must be such that the water vapor is cooled and condenses in the hose before reaching the water separator.

If the ambient temperature is below 32 °F (0 °C) the hose must be short enough to prevent the water from freezing before reaching the water separator.

Lubrication

The lubricant is important for the machine's function and has a great impact on the useful service life.

Every day before using and after each eight hours service, fill the integrated oil reservoir with recommended lubricant.

Use a synthetic lubricant such as AC Airolene Plus Tool Oil or mineral oil with the properties recommended in the table below.

Lubricant	Temperature range °F (°C)	Viscosity
AC Airolene Plus Tool Oil	-4 to +120 (-20 to +50)	-
Air tool oil	-4 to +60 (-20 to +15)	100-150 SUS (ISO VG 22-32)
Air tool oil	+60 to +120 (+15 to +50)	225-350 SUS (ISO VG 46-68)

Oiler adjustment

Every day before using and after each eight hours service, fill the integrated oil reservoir with recommended oil.

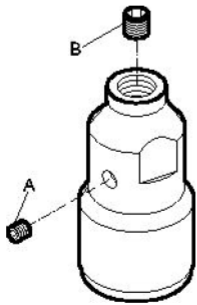

1. Remove the oil plug (A) and fill the integrated oil reservoir with recommended oil.
2. If oiler adjustment is needed, adjust the oil regulating plug (B), clockwise to reduce flow and counter clockwise to increase flow.

Fitting and removing the butt

Whenever fitting or removing the butt the following instructions must be observed:

- ◆ To prevent an accidental start: switch off the air supply and disconnect the machine from the power source. Bleed the machine by pressing the start and stop device.

Removing

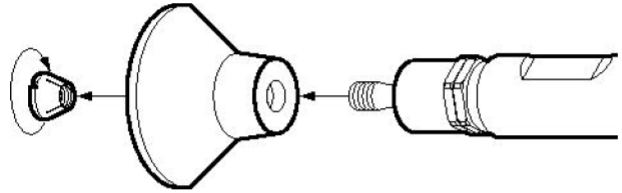

1. Unscrew the lock nut.
2. The butt is fitted to the piston with a taper, so careful use of a hammer might be needed. Be careful not to cause damage to the sealing surface on the piston rod.

Fitting

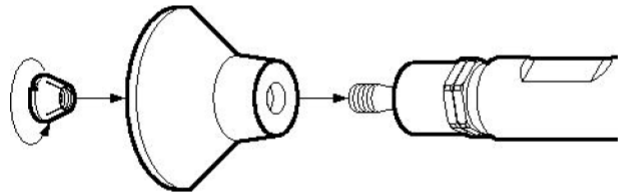

Before fitting the butt, carefully check that the contact surfaces are clean, both the taper on the piston rod and inside the butt.

1. Lubricate the threads.
2. Tighten the lock nut. For the correct torque, see section "Tightening torques".
3. Check that the butt is properly pressed up on the piston rod taper.

Operation

▲ WARNING Involuntary start

Involuntary start of the machine may cause injury.

- ▶ Keep your hands away from the start and stop device until you are ready to start the machine.
- ▶ Learn how the machine is switched off in the event of an emergency.
- ▶ Stop the machine immediately in all cases of power supply interruption.

Start and stop



Start the machine by squeezing the start and stop device while firmly holding the handle.

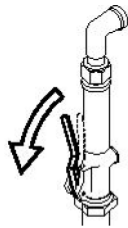

Stop the machine by releasing the start and stop device. The start and stop device returns automatically to the stop position.

Operating

Compacting

- ◆ Stand in a stable position with your feet well away from the butt.
- ◆ Hold the tamper in a vertical position and press it slightly against the working surface before you start.
- ◆ Strive to find a feed force that makes the tamper move as little as possible vertically.
- ◆ Let the machine do the work; do not press too hard.

- ◆ Avoid making contact with solid materials for example granite and concrete which would cause substantial vibrations and uncontrollable movements of the tamper.
- ◆ Any form of idling, operating without a butt or operating with an uplifted machine must be avoided.
- ◆ Check regularly that the machine is well lubricated.

When taking a break

- ◆ During all breaks you must place the machine in such a way that there is no risk for it to be unintentionally started. Make sure to place the machine on the ground, so that it can not fall.
- ◆ In the event of a longer break or when leaving the workplace: Switch off the power supply and then bleed the machine by activating the start and stop device.

Maintenance

Regular maintenance is a basic requirement for the continued safe and efficient use of the machine. Follow the maintenance instructions carefully.

- ◆ Before starting maintenance on the machine, clean it in order to avoid exposure to hazardous substances. See “Dust and fume hazards”
- ◆ Use only authorised parts. Any damage or malfunction caused by the use of unauthorised parts is not covered by warranty or product liability.
- ◆ When cleaning mechanical parts with solvent, comply with appropriate health and safety regulations and ensure there is satisfactory ventilation.
- ◆ For major service to the machine, contact your nearest authorised workshop.
- ◆ After each service, check that the machine's vibration level is normal. If not, contact your nearest authorised workshop.

Every day

Before undertaking any maintenance or changing the butt on pneumatic machines, always switch off the air supply and bleed the machine by depressing the start and stop device. Then disconnect the air hose from the machine.

- ◆ Clean and inspect the machine and its functions each day before the work commences.
- ◆ Check that the butt is properly fitted.
- ◆ Conduct a general inspection for leaks and damage.
- ◆ Check that the air inlet nipple is tightened and that the claw coupling is free from damage.
- ◆ Check the tamping butt lock nut, it must be tightened securely.
- ◆ Check the setting of the piston rod seal. See section "Adjustment of the piston rod seal".
- ◆ Change damaged parts immediately.
- ◆ Replace worn components in good time.
- ◆ Make sure that all the attached and related equipment, such as hoses and water separators are properly maintained.

Periodic maintenance

After each operating period of approximately 150 impact hours or twice a year the machine must be dismantled and all parts be cleaned and checked. This work must be performed by authorised staff, trained for this task.

Tightening torques

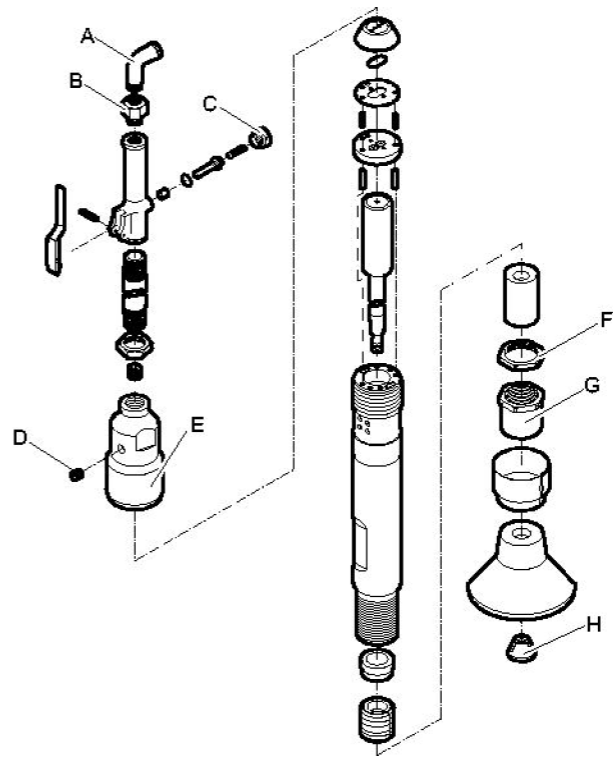

- A. Elbow - street, 30-40 lbf/ft (41-56 Nm) (use Loctite® 242™).
- B. Strainer - air, 50-60 lbf/ft (68-81 Nm) (use Loctite® 542™).
- C. Cap - valve, 60-70 lbf/ft (81-95 Nm) (use Loctite® 542™).
- D. Plug - filler, 20-25 lbf/ft (27-34 Nm).
- E. Cylinder - head, 125-160 lbf/ft (169-217 Nm).
- F. Lock nut - retainer, 90-100 lbf/ft (122-136 Nm).
- G. Retainer - piston bushing, 2-4 lbf/ft (3-5 Nm).
- H. Lock nut - butt, 60-90 lbf/ft (81-122 Nm).

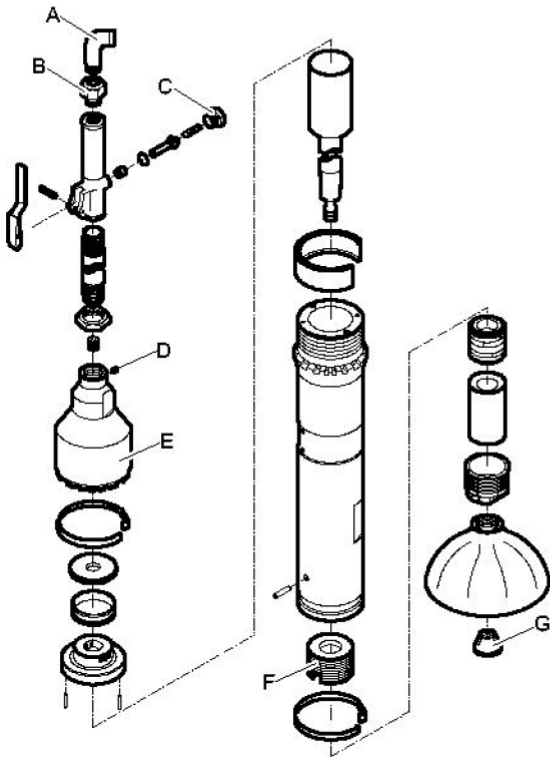

- A. Elbow - street, 30-40 lbf/ft (41-56 Nm) (use Loctite® 242™).
- B. Strainer - air, 50-60 lbf/ft (68-81 Nm) (use Loctite® 542™).
- C. Cap - valve, 60-70 lbf/ft (81-95 Nm) (use Loctite® 542™).
- D. Plug - filler, 15 lbf/ft (20 Nm).
- E. Cylinder - head, 125-160 lbf/ft (169-217 Nm).
- F. Bushing - cylinder, 100 lbf/ft (136 Nm).
- G. Lock nut - butt, 80-110 lbf/ft (108-149 Nm).

Loctite is a registered trademark of Henkel Corporation. 242 and 542 are trademarks of Henkel Corporation.

Adjustment of the piston rod seal

Before undertaking any kind of maintenance, installation, inspection, or cleaning, switch off the air supply, bleed the machine by activating the start and stop device and disconnect the machine from the power source.

The setting of the piston rod seal should be checked daily. Using the tamper with a leakage between the seal and the piston rod will cause damage to the piston and the cylinder. Check by moving the piston by hand. A slight drag should be noticed. Adjust the seal if necessary.

Adjustment of the seal

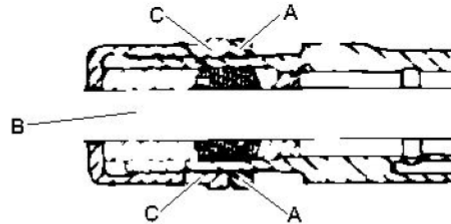

1. Loosen the lock nut (A).
2. Tighten the retainer (C) until the piston (B) does not move.
3. Back off the lock nut (A) until the piston (B) moves with a slight drag, when moved by hand.
4. Tighten the lock nut (A).

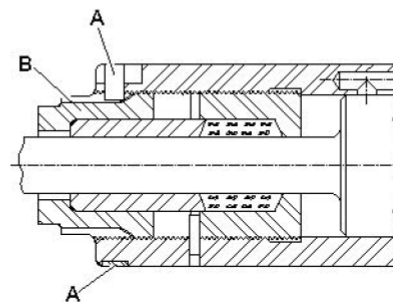

1. Remove the lock clip (A).
2. Tighten the gland nut (B) until the piston does not move.
3. Back off the gland nut (B) until the piston moves with a slight drag, when moved by hand.
4. Fit the lock clip (A) into the mating slots of the cylinder and the gland nut (B).

Troubleshooting

If the pneumatic machine does not start, has low power or uneven performance, check the following points.

- ◆ Check that the pneumatic machine is getting the correct amount of lubricant. Too much lubrication can cause starting problems, low power or uneven performance.
- ◆ Check that the compressed air system supplies the machine with sufficient air pressure to give full power.
- ◆ Check that the dimension and length of the air hose are according to the recommendations. See “Installation”.
- ◆ If there is a risk of freezing, check that the machine's exhaust ports are not blocked.
- ◆ If the machine function is still not satisfactory after this procedure, contact an authorised service workshop.

Storage

- > Clean the machine properly before storage, in order to avoid hazardous substances. See “Dust and fume hazard”
- > Pour approximately 1/2 oz (5 cl) of oil directly into the air inlet nipple, connect the machine to the compressed air supply and start it for a few seconds.
- > Always store the machine in a dry place.

Disposal

A used machine must be treated and disposed of in such a way that the greatest possible portion of the material can be recycled and any negative influence on the environment is kept as low as possible, and in respect to local restrictions.

Noise and vibration declaration statement

Guaranteed sound effect level **L_w** according to ISO 3744 in accordance with directive 2000/14/EC.

Sound pressure level **L_p** according to ISO 11203.

Vibration value **A** and uncertainty **B** according to EN 12096. Values determined according to ISO 8662-5. See table "Noise and vibration data" for the values of A, B, etc.

These declared values were obtained by laboratory type testing in accordance with the stated directive or standards and are suitable for comparison with the declared values of other tools tested in accordance with the same directive or standards. These declared values are not adequate for use in risk assessments and values measured in individual work places may be higher. The actual exposure values and risk of harm experienced by an individual user are unique and depend upon the way the user works, in what material the breaker is used, as well as upon the exposure time and the physical condition of the user, and the condition of the breaker.

We, Atlas Copco, cannot be held liable for the consequences of using the declared values, instead of values reflecting the actual exposure, in an individual risk assessment in a work place situation over which we have no control.

Additional vibration information

This tool may cause hand-arm vibration syndrome if its use is not adequately managed.

This additional vibration information may be of assistance to employers in meeting their obligations (for example under EU Directive 2002/44/EC) to assess the risks to their workers arising from hand arm vibration associated with the use of this tool.

The vibration emission varies greatly with task and operator technique. The declared vibration value relates to a single axis on the D-handle and much higher vibration levels may occur at other hand positions or measurement directions.

We believe that normal intended use of the tool will usually produce three axes vibration emissions in the range of **C** m/s² when breaking concrete and in the range of **E** m/s² when breaking brick (vibration total value according to the definition in ISO 5349-1:2001) depending on the details of the task, but emissions outside this range may occur for some applications.

A figure of **D** m/s² for concrete and **F** m/s² for brick is probably a usable average emission value when, for example, estimating the likely average exposure (and hence risk in accordance with EU-directive 2002/44/EC) of users performing a wide range of tasks within the intended use of the tool. We point out that application of the tool to a sole specialist task may produce a different average emission and in such cases we strongly recommend a specific evaluation of the vibration emission.

We recommend a programme of health surveillance to detect early symptoms that may relate to vibration exposure, so that management procedures can be modified to help prevent significant disability.

Unauthorized use or copying of all or part of the contents is prohibited. This specifically applies to trademarks, model designations, parts numbers and drawings.

