

THE NEW RELIANT™ RS45 – THE MOST POWERFUL, LIGHTWEIGHT, AIR COMPRESSOR IN ITS CLASS

RELIANT™ RS45



55% Lighter. Quieter Operation. More Air Power Than the Competition.

Vanair once again is listening and meeting the demands of the marketplace with the introduction of the new Reliant™ RS45 air compressor; the most powerful, lightweight system in its class. At 55% less weight than its predecessor, the RS45's featherweight rust-proof aluminum canopy reduces truck weight and fuel consumption. Providing an impressive 45 cfm and 150 psi of on-demand air power at 100% duty cycle, the RS45 has the highest cfm rating in its class. Advanced sound attenuation technology has significantly reduced the sound level on the machine. Quieter, lighter and more powerful, the RS45 will meet your toughest challenges out in the field.

SPECIFICATIONS

Capacity (CFM)	30	30	30	35	35	35	40	40	40	45	45	45
Air Pressure (PSI)	100	125	150	100	125	150	100	125	150	100	125	150
Hydraulic Flow (GPM)*	7	7.2	7.3	8.3	8.4	8.6	9.6	9.7	9.8	11	11.1	11.2
Hydraulic Pressure (PSI)*	1950	2175	2375	2000	2200	2450	2050	2250	2475	2150	2350	2550

Dimensions with fittings (In.):
35.3L X 21W X 22.81H | Dry Weight (Lbs.): 195

* Ratings are approximate and are based on 120 °F hydraulic fluid temperature. Add 400 PSI minimum to hydraulic requirements for hydraulic system continuous pressure ratings. Consult Vanair® for specific details.

Product improvement is a continuing goal. Design and specifications are subject to change without notice or obligation.
RELIANT RS45_01242018



PERFORMANCE/FEATURES

- 30-45 CFM and Up to 150 PSI
- Lightweight - Only 195 lbs
- Quiet - Only 74 dBA @ 7 meters
- 12V and 24V DC Models Available

ENCAPSULATED AIR COMPRESSOR

- Rotary Screw Air Compressor
- Bolt-On Electric Inlet Valve
- Integral Air-to-Oil Separator Tank
- Lifetime Warranty on Air End

AIR-TO-OIL COOLER

- Capable of Cooling Up to 175 PSI
- Ambient Operating Range of -20 °F to + 125 °F

HYDRAULIC COOLER

- Integrated Cooler Reduces Heat in Truck Hydraulic System

HYDRAULICS

- Gear-Type Motor
- Hydraulic Oil In - 1/2" 37 Degree JIC (#12)
- Hydraulic Oil Out - 3/4" 37 Degree JIC (#16)
- Open Center or Closed Center
- Hydraulic Case Drain - 3/8" 37 Degree JIC (#6)
- Hydraulic Load Sense Line - 1/4" 37 Degree JIC (#4)*

INSTRUMENTATION

- Conveniently Located and Easy to Read or Remote Mountable
- LED Electronic Display for Temperature, Pressure, and Machine Hours

SAFETY EQUIPMENT

- Air Pressure Relief Safety Valve
- Hydraulic Oil Pressure Relief Valve
- Automatic Blow-Down on Shutdown
- High-Temperature and High-Pressure
- Compressor Shutdown
- Oil Fill Plug Safety Relief

SERVICEABILITY/CONVENIENCE

- Reversible Hinged Hood and Oil Fill Service
- Access Panel for Easy Accessibility
- JIC Fittings on Front of Machine for Hydraulic and Air Connections for Convenience

CANOPY

- Lightweight Powder-Coated Aluminum Sheet Metal Enclosure
- Single Point Lifting Bail

*Load sense line for closed center hydraulic system only.

HYDRAULIC SYSTEM REQUIREMENTS

All hydraulic ratings and pressures are at the machine and do not take into account the pressure drops of individual hydraulic systems. These pressure drops need to be taken into account and added to the rating of the hydraulic pump and components. Vanair highly recommends consulting a hydraulic supply expert for specifying the correct hydraulic pump size and type, oil reservoir size, hydraulic cooler, hydraulic pressure relief, and other hydraulic supply components for your application. Please take into consideration the following: The hydraulic flow and pressure requirements of the air compressor, the continuous hydraulic load when the compressor is running, the duty cycle and ambient operating temperatures, and any other hydraulic equipment that may share the same hydraulic supply system (Vanair recommends a dedicated pump and hydraulic circuit).

OPTIONS/ACCESSORIES

- Cold Weather Package with Thermal Valve
- 20 - 60 Gallon Air Reservoirs
- Aftercoolers
- Air Hoses
- Air Tools
- Hose Reels and Fittings
- OSHA Safety Valve (Velocity Fuse)
- Service/Control Line Moisture Separators
- Tool Oiler/Lubricator
- Service Airline De-Icer
- Filter Regulator Lubricator (FRL) 1/2"

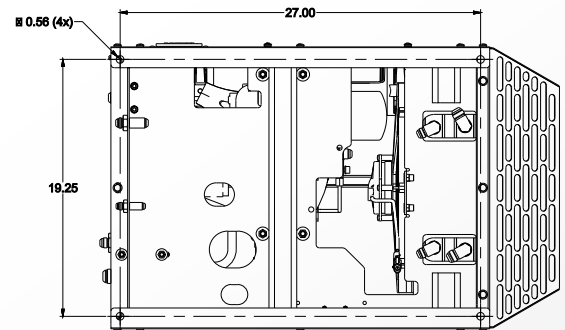
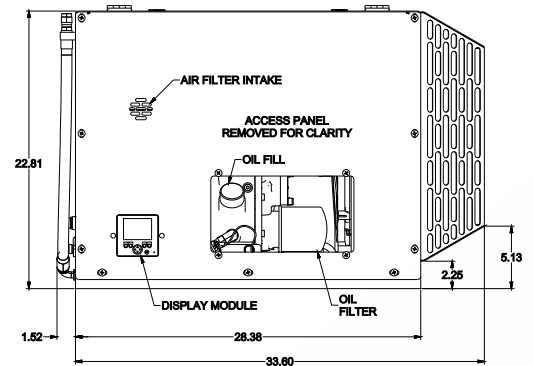
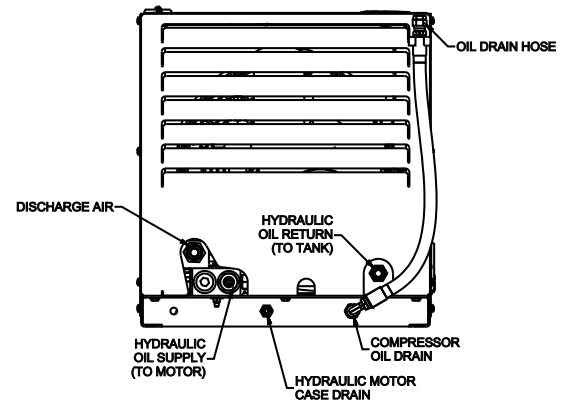

Bottom view with mounting pattern