

# AIR N ARC<sup>®</sup>

BY VANAIR<sup>®</sup>

ALL-IN-ONE Power Systems<sup>®</sup>

## AIR N ARC<sup>®</sup> 300

### ALL-IN-ONE POWER SYSTEMS<sup>®</sup> WELDER • GENERATOR • AIR COMPRESSOR • BATTERY BOOSTER OPERATION MANUAL & PARTS LIST

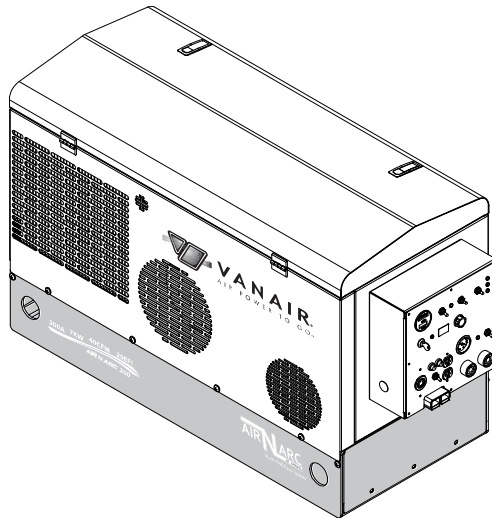

#### NOTE



Read this manual before installing, operating or servicing this equipment. Failure to comply with the operation and maintenance instructions in this manual WILL VOID THE EQUIPMENT WARRANTY.

#### NOTE

Making unauthorized modifications to the system components WILL VOID THE WARRANTY!

Always inform Vanair Manufacturing, Inc., before beginning any changes to the Air N Arc system.

Vanair Manufacturing, Inc.

10896 West 300 North  
Michigan City, IN 46360

Phone: (219) 879-5100  
(800) 526-8817

Service Fax: (219) 879-5335

Parts Fax: (219) 879-5340

Sales Fax: (219) 879-5800

[www.vanair.com](http://www.vanair.com)

#### NOTE

Use only Vanair Vanguard™ Premium Synthetic Oil and Genuine Vanair Parts. Inspect and replace damaged components before operation. Substituting non-Vanguard™ Oil or non-genuine Vanair filter components WILL VOID THE COMPRESSOR WARRANTY!



**VANAIR**<sup>®</sup>  
AIR POWER TO GO™

090010-OP\_r0

Effective Date: -  
3-12

©Vanair Manufacturing, Inc.

**AIR N ARC®  
ALL-IN-ONE POWER-SYSTEMS®**

**RELIANT™ SERIES**

**POWERFLEX™ SERIES**

**PRO SERIES**

**CONTRACTOR SERIES**

**VIPER™ SERIES**

**FST™ SERIES**

**(844) VAN - SERV**

**SERVICE@VANAIR.COM**

**PARTS@VANAIR.COM**

**10896 W. 300 N.  
MICHIGAN CITY, IN 46360**

**(800) 526-8817**

**VANAIR.COM**

**EFFECTIVE: JAN 8, 2016**

090088\_r1

# VANAIR VANTAGE WARRANTY

This limited warranty supersedes all previous Vanair warranties and is exclusive with no other guarantees or warranties expressed or implied.

**LIMITED WARRANTY**—Subject to the expressed terms and conditions set forth below, Vanair Mfg., Inc. ("Vanair"), of Michigan City, Indiana (USA), warrants to the original retail purchaser of new Vanair equipment that such equipment is free from defects in materials and workmanship when shipped by Vanair.

For warranty claims received by Vanair within the applicable warranty periods described below, Vanair will repair or replace any warranted equipment, parts or components that fail due to defects in material or workmanship or refund the purchase price for the equipment, at Vanair's discretion. Vanair is not responsible for time or labor to gain access to the machine to perform work. **WARRANTY WILL BE VOID IF GENUINE VANAIR PARTS AND FLUIDS ARE NOT USED.**

Vanair must be notified in writing within thirty (30) days of any such defect or failure. No warranty work or returns without prior authorization is allowed. Vanair will provide instructions on the warranty claim procedures to be followed.

Warranty will commence upon receipt of the Warranty Registration Card. If the Warranty Registration Card is not received within six (6) months of shipment from Vanair, the warranty commencement date shall be thirty (30) days from the date of shipment from Vanair. Records of warranty adherence are the responsibility of the end user.

1. Lifetime Warranty Parts – 3 Years Labor
  - Rotary Screw Air Compressor Air End
2. 6 Years Parts – 3 Years Labor
  - Vanair Super Capacitor (VSC)
3. 3 Years Parts – 1 Year Labor
  - Reciprocating Compressor Air End
  - Generators
  - Welders
4. 2 Years Parts – 1 Year Labor
  - Hydraulic Motors
  - Hydraulic Pumps
5. 1 Year Parts – 1 Year Labor
  - All electronics including, but not limited to:
    - (i) I/O Boards
    - (ii) Modules
    - (iii) Panel Boxes
    - (iv) Instrumentation
    - (v) Clutches
    - (vi) Solenoids
    - (vii) Running Gear/Trailers
    - (viii) Compressor/Hydraulic Coolers, including Fan and Radiator Core

This Limited Warranty shall not apply to:

1. Consumable components, such as shaft seals, valves, belts, filters, capacitors, contactors, relays, brushes or parts that fail due to normal wear and use.
2. Items furnished by Vanair, but manufactured by others, such as engines and trade accessories (these items are covered by the manufacturer's warranty, if any).
3. Equipment that has been modified by any party other than Vanair or equipment which has not been used and maintained in accordance with Vanair's specifications.
4. Equipment which has been improperly installed and/or improperly operated, based upon Vanair's specifications for the equipment or industry standards.
5. Equipment installed by non-authorized or third party personnel.

Vanair products are intended for purchase and use by commercial/industrial users and persons trained and experienced in the use and maintenance of industrial equipment.

In the event of a warranty claim covered by this Limited Warranty, the exclusive remedies shall be, at Vanair's sole discretion: (i) repair; or (ii) replacement; (iii) where authorized in writing by Vanair in appropriate cases, the reasonable cost of repair or replacement at an authorized Vanair service facility; or (iv) payment of (or credit for) the purchase price (less reasonable depreciation based upon actual use) upon return of the equipment at the warranty claimant's risk and expense. Vanair will pay standard ground freight for any warranty item shipped to and from Vanair or (Vanair designated facility) within the first year of the applicable warranty period. Any additional expedited freight cost is the responsibility of the purchaser.

TO THE GREAT EXTENT PERMITTED BY APPLICABLE LAW, THE REMEDIES PROVIDED HEREIN ARE THE SOLE AND EXCLUSIVE REMEDIES APPLICABLE TO THE VANAIR EQUIPMENT. IN NO EVENT SHALL VANAIR BECOME LIABLE FOR DIRECT, INDIRECT, SPECIAL, PUNITIVE, INCIDENTAL OR CONSEQUENTIAL DAMAGES (INCLUDING LOSS OF PROFIT OR LOST BUSINESS OPPORTUNITY), WHETHER BASED ON CONTRACT, TORT OR ANY OTHER LEGAL THEORY. IN NO EVENT SHALL VANAIR BECOME OBLIGATED TO PAY MORE ON ANY WARRANTY CLAIM THAN THE PURCHASE PRICE ACTUALLY PAID BY THE ORIGINAL RETAIL PURCHASER.

THIS LIMITED WARRANTY IS MADE IN LIEU OF ALL OTHER WARRANTIES, EXPRESS OR IMPLIED, INCLUDING THE WARRANTIES OF MERCHANTABILITY AND/OR FITNESS FOR A PARTICULAR PURPOSE, OR ANY OTHER WARRANTY OR GUARANTY ARISING BY OPERATION OF LAW. ANY WARRANTY NOT EXPRESSLY PROVIDED HEREIN, IMPLIED WARRANTY, GUARANTY AND ANY REPRESENTATION REGARDING THE PERFORMANCE OF THE EQUIPMENT, AND ANY REMEDY FOR BREACH OF CONTRACT, IN TORT, OR ANY OTHER LEGAL THEORY WHICH, BUT FOR THIS PROVISION, MIGHT ARISE BY IMPLICATION, OPERATION OF LAW, CUSTOM OF TRADE, OR COURSE OF DEALING ARE EXCLUDED AND DISCLAIMED BY VANAIR.

Some states in the United States of America do not allow limitations of how long an implied warranty lasts, or the exclusion of incidental, indirect, special or consequential damages, and as such, the above limitations and exclusions may not apply to you. This warranty provides specific legal rights. Other rights may be available to you, but may vary from state to state.

In Canada, legislation in some provinces provides for certain additional warranties or remedies other than as stated herein, and to the extent that they may not be saved, the limitations and exclusions set out forth above may not apply. This Limited Warranty provides specific legal rights, and other rights may be available, but may vary from province to province.



**VANAIR®**  
MOBILE POWER SOLUTIONS™

# TABLE OF CONTENTS

---



---

**WARRANTY ..... BEHIND COVER**

**TABLE OF CONTENTS.....I**

**GLOSSARY.....IX**

G.1 GENERAL TERMS AND DEFINITIONS ..... IX

G.2 WELDING TERMS AND DEFINITIONS..... IX

G.3 AIR COMPRESSOR TERMS AND DEFINITIONS ..... X

**WARRANTY CLAIMS PROCEDURE ..... XIII**

CLAIMS PROCESS FOR WARRANTED PARTS ..... XIII

PROCEDURE ..... XIII

RETURN MATERIAL AUTHORIZATION FORM..... XVI

**INTRODUCTION..... 1**

EXPERIENCE THE VANAIR ADVANTAGE ..... 1

**SECTION 1: SAFETY ..... 3**

1.1 GENERAL INFORMATION ..... 3

1.2 DANGERS, WARNINGS, CAUTIONS, AND NOTES ..... 3

1.3 INTERNATIONAL SAFETY SYMBOL ..... 4

1.4 ARC WELDING HAZARDS..... 4

    1.4.1 ELECTRICAL SHOCK CAN KILL..... 4

    1.4.2 FUMES AND GASSES CAN BE HAZARDOUS ..... 6

    1.4.3 BUILD UP OF GAS CAN INJURE OR KILL ..... 6

    1.4.4 ENCLOSED SPACES CAN CAUSE A BUILD-UP OF NOXIOUS FUMES AND OVERHEATING..... 7

    1.4.5 ARC RAYS CAN BURN EYES AND SKIN ..... 7

    1.4.6 WELDING CAN CAUSE FIRE AND EXPLOSION ..... 7

    1.4.7 FLYING METAL CAN INJURE EYES ..... 8

    1.4.8 HOT PARTS CAN CAUSE SEVERE BURNS ..... 9

    1.4.9 NOISE CAN DAMAGE HEARING..... 9

    1.4.10 MAGNETIC FIELDS CAN AFFECT PACEMAKERS..... 9

<b>Continued on next page...</b>
----------------------------------

## SECTION 1: SAFETY (CONTINUED)

1.4.11	CYLINDERS CAN EXPLODE IF DAMAGED.....	9
1.5	ENGINE HAZARDS.....	10
1.5.1	BATTERY EXPLOSION CAN BLIND.....	10
1.5.2	FUEL CAN CAUSE FIRE OR EXPLOSION.....	10
1.5.3	MOVING PARTS CAN CAUSE INJURY.....	11
1.5.4	HOT PARTS CAN CAUSE SEVERE BURNS.....	11
1.5.5	ENGINE EXHAUST GASES CAN KILL.....	11
1.5.6	ENCLOSED SPACES CAN CAUSE A BUILD-UP OF NOXIOUS FUMES AND OVERHEATING.....	11
1.5.7	BATTERY ACID CAN BURN SKIN AND EYES.....	12
1.5.8	ENGINE HEAT CAN CAUSE FIRE.....	12
1.5.9	EXHAUST SPARKS CAN CAUSE FIRE.....	12
1.6	COMPRESSED AIR HAZARDS.....	12
1.6.1	BREATHING COMPRESSED AIR CAN CAUSE SERIOUS INJURY OR DEATH.....	12
1.6.2	ENCLOSED SPACES CAN CAUSE A BUILD-UP OF NOXIOUS FUMES AND OVERHEATING.....	12
1.6.3	COMPRESSED AIR CAN CAUSE INJURY.....	13
1.6.4	TRAPPED AIR PRESSURE AND WHIPPING HOSES CAN CAUSE INJURY.....	13
1.6.5	HOT METAL FROM AIR ARC CUTTING AND GOUGING CAN CAUSE FIRE OR EXPLOSION.....	13
1.6.6	HOT PARTS CAN CAUSE SEVERE BURNS.....	13
1.6.7	READ INSTRUCTIONS.....	13
1.7	ADDITIONAL SYMBOLS FOR INSTALLATION, OPERATION AND MAINTENANCE.....	14
1.7.1	FALLING UNIT CAN CAUSE INJURY.....	14
1.7.2	OVERHEATING CAN DAMAGE MOTORS.....	14
1.7.3	FLYING SPARKS CAN CAUSE INJURY.....	14
1.7.4	OVERUSE CAN CAUSE OVERHEATING.....	14
1.7.5	ENCLOSED SPACES CAN CAUSE A BUILD-UP OF NOXIOUS FUMES AND OVERHEATING.....	15
1.7.6	TILTING OF TRAILER CAN CAUSE INJURY.....	15
1.7.7	READ INSTRUCTIONS.....	15
1.7.8	H.F. RADIATION CAN CAUSE INTERFERENCE.....	15
1.7.9	ARC WELDING CAN CAUSE INTERFERENCE.....	16
1.8.	CALIFORNIA PROPOSITION 65 WARNINGS.....	16
1.9	PRINCIPAL SAFETY STANDARDS.....	17
1.10	EMF INFORMATION.....	18
1.11	MACHINE CANOPY ACCESS SAFETY SWITCHES.....	18
1.12	DISPOSING OF MACHINE FLUIDS.....	19

**Continued on next page...**

**SECTION 2: DESCRIPTION .....21**

FIGURE 2-1: MAJOR MACHINE COMPONENTS LOCATIONS..... 20

2.1 GENERAL DESCRIPTION ..... 21

2.2 COMPRESSED AIR SYSTEM..... 21

    2.2.1 COMPRESSOR UNIT ..... 21

    2.2.2 ELECTRONIC INLET VALVE ..... 22

    2.2.3 AIR INLET FILTER ..... 22

    2.2.4 SECONDARY SPIN-ON AIR/OIL COALESCER..... 22

    2.2.5 MINIMUM PRESSURE/CHECK VALVE ..... 23

    2.2.6 PRESSURE RELIEF VALVE ..... 23

    2.2.7 ADJUSTABLE PRESSURE SWITCH..... 23

    2.2.8 OIL RESERVOIR AND PRIMARY AIR/OIL SEPARATOR..... 24

2.3 OIL COOLING SYSTEM ..... 24

    2.3.1 FAN TEMPERATURE SWITCHES..... 24

    2.3.2 COMPRESSOR SPIN-ON OIL FILTER..... 25

2.4 ENGINE..... 25

2.5 AC GENERATOR ..... 26

2.6 INSTRUMENTATION ..... 27

    2.6.1 VOLTS/AMPS METER ..... 28

    2.6.2 WELDER FUNCTION SWITCHES..... 28

    2.6.3 DC CHARGER MODE TOGGLE SWITCH..... 28

    2.6.4 VOLTS/AMPS MANUAL ADJUSTMENT DIAL..... 28

    2.6.5 COMPRESSOR ON/OFF TOGGLE SWITCH..... 30

    2.6.6 COMPRESSOR AIR PRESSURE SWITCH/GAUGE..... 30

    2.6.7 WELDER LEAD CONNECTION..... 30

    2.6.8 BATTERY CABLE RECEPTACLE ..... 30

    2.6.9 GENERATOR CONTROL ON/OFF TOGGLE SWITCH..... 30

    2.6.10 AC VOLTAGE OUTLETS..... 30

    2.6.11 CIRCUIT BREAKER OVERLOAD TRIP/RESET BUTTONS..... 30

    2.6.12 ENGINE CONTROL (ON/OFF/START) SWITCH..... 31

    2.6.13 FUEL GAUGE/HOUR METER ..... 31

**SECTION 3: SPECIFICATIONS .....33**

TABLE 3A: WELDER, GENERATOR, AND ENGINE SPECIFICATIONS..... 33

TABLE 3B: SPECIFICATIONS — AIR COMPRESSOR ..... 33

TABLE 3C: SPECIFICATIONS — UNIT WEIGHT AND DIMENSIONS..... 34

**Continued on next page...**

## SECTION 3: SPECIFICATIONS (CONTINUED)

TABLE 3D: BOLT AND TORQUE SPECIFICATIONS ..... 34  
 TABLE 3E: VARIOUS FUNCTION ACCEPTABLE TESTING OUTPUT RANGES ..... 35  
 TABLE 3F: GENUINE VANGUARD™ OIL CHARACTERISTICS ..... 35

## SECTION 4: OPERATION ..... 37

4.1 MACHINE PACKAGE RECEIPT/INSPECTION ..... 37  
 4.2 MACHINE PACKAGE PREP ..... 37  
 4.3 SERVICE BODY PREP ..... 37  
 4.4 MACHINE PACKAGE MOUNTING ..... 39  
 4.5 INSTALLATION AND DIMENSIONS DIAGRAM (PART 1 OF 2) ..... 42  
 4.5 INSTALLATION AND DIMENSIONS DIAGRAM (PART 2 OF 2) ..... 43

## SECTION 5: OPERATION ..... 45

5.1 GENERAL INFORMATION ..... 45  
 5.2 ENGINE START-UP AND SHUTDOWN PROCEDURE ..... 46  
     5.2.1 ENGINE START-UP ..... 47  
     5.2.2 ENGINE SHUTDOWN ..... 47  
 5.3 ENGINE THROTTLE CONTROL FUNCTIONS ..... 48  
 5.4 OPERATING THE WELDER ..... 49  
     5.4.1 WELDER OPERATING PROCEDURE ..... 49  
         5.4.1.1 CC (CONSTANT CURRENT) MODE ..... 49  
         5.4.1.2 CV (CONSTANT VOLTAGE) MODE - USING A VOLTAGE SENSING SUITCASE FEEDER ..... 50  
         5.4.1.3 CV (CONSTANT VOLTAGE) MODE - USING A SPOOL GUN ..... 51  
 5.5 OPERATING THE GENERATOR ..... 52  
 5.6 OPERATING THE AIR COMPRESSOR ..... 53  
 5.7 OPERATING THE BATTERY BOOSTER/CHARGER ..... 54  
     5.7.1 CONNECTION - DISCONNECTION SEQUENCE AND OPERATION ..... 55

## SECTION 6: MAINTENANCE ..... 57

6.1 GENERAL INFORMATION ..... 57  
 6.2 ROUTINE MAINTENANCE SCHEDULE ..... 57  
 6.3 MAINTENANCE SCHEDULE TABLE ..... 59  
 6.4 REPLACEMENT PARTS ..... 63  
 6.5 PARTS REPLACEMENT AND ADJUSTMENT PROCEDURES ..... 63  
     6.5.1 COMPRESSOR AIR FILTER ..... 65  
         6.5.1.1 COMPRESSOR AIR FILTER CHECK ..... 65

**Continued on next page...**

## SECTION 6: MAINTENANCE (CONTINUED)

6.5.1.2	COMPRESSOR AIR FILTER INSPECTION.....	66
6.5.1.3	COMPRESSOR AIR FILTER REPLACEMENT.....	66
6.5.2	REPAIRING THE AIR INLET VALVE.....	67
6.5.3	CHECKING THE COMPRESSOR OIL.....	69
6.5.4	REPLACING THE COMPRESSOR OIL FILTER.....	70
6.5.5	CHANGING THE COMPRESSOR OIL.....	72
6.5.6	REPLACING THE SPIN-ON AIR/OIL COALESCER.....	73
6.5.7	REPAIRING THE COMPRESSOR SHAFT SEAL.....	74
6.5.7.1	PART I - REMOVING THE COMPRESSOR SERPENTINE BELT.....	74
6.5.7.2	PART II - ACCESSING THE COMPRESSOR UNIT SHAFT SEAL.....	76
6.5.7.3	PART III - REPLACING THE COMPRESSOR SERPENTINE BELT.....	77
6.5.8	REPLACING THE AIR INLET SOLENOID VALVE.....	78
6.5.8.1	SOLENOID VALVE - PREPARATION BEFORE MOUNTING.....	78
6.5.8.2	CONNECTING THE NEW SOLENOID VALVE.....	80
6.5.9	DRAINING THE AIR TANK.....	81
6.5.10	CHECKING THE AIR TANK RELIEF VALVE.....	82
6.5.11	REBUILDING THE MINIMUM PRESSURE/CHECK VALVE.....	82
6.5.11.1	SETTING THE MINIMUM PRESSURE VALVE.....	84
6.5.12	INSPECTING THE SYSTEM COOLERS.....	84
6.5.13	CHECKING THE ENGINE OIL.....	84
6.5.14	ADJUSTING THE ENGINE SPEED.....	86
6.5.15	ADJUSTING THE PRESSURE SETTING.....	86
6.5.16	REPLACING AND RE-TENSIONING THE SERPENTINE DRIVE BELTS.....	88
6.5.16.1	RE-TENSIONING THE AIR COMPRESSOR SERPENTINE BELT.....	88
6.5.16.2	REPLACING THE AIR COMPRESSOR SERPENTINE BELT.....	90
6.5.16.3	RE-TENSIONING THE GENERATOR SERPENTINE BELT.....	92
6.5.16.4	REPLACING THE GENERATOR SERPENTINE BELT.....	92
6.6	SERVICING THE SYSTEM FUSES AND CIRCUIT BREAKERS.....	94
6.7	EXTREME CONDITION OPERATION.....	95
6.7.1	COLD WEATHER OPERATION.....	97
6.7.1.1	ENGINE OPERATION.....	97
6.7.2	HIGH TEMPERATURE OPERATION.....	97
6.7.3	HIGH ALTITUDE OPERATION.....	97

**Continued on next page...**

## **SECTION 6: MAINTENANCE (CONTINUED)**

- 6.8 STORAGE AND INTERMITTENT USE..... 98
- 6.8.1 INTERMITTENT USE ..... 98
- 6.8.2 LONG TERM STORAGE ..... 98

## **SECTION 7: TROUBLESHOOTING ..... 99**

- 7.1. GENERAL INFORMATION ..... 99
- 7.2 TROUBLESHOOTING GUIDE ..... 100

## **SECTION 8: DIAGRAMS ..... 111**

- 8.1 GENERAL INFORMATION ..... 111
- 8.2 WIRING DIAGRAM - AIR N ARC 300 SERIES ..... 112
- 8.3 WIRING DIAGRAM - SWITCHES & LIGHTS ..... 113
- 8.4 TRUNK LINE ASSEMBLY HARNESS..... 114
- 8.5 COMPRESSOR FLOW SCHEMATIC DIAGRAM..... 115

## **SECTION 9: ILLUSTRATED PARTS LIST..... 117**

- 9.1 PARTS ORDERING PROCEDURE..... 117
- TABLE 9A: RECOMMENDED SPARE PARTS LIST ..... 118
- 9.2 AIR N ARC 300 SYSTEMS ASSEMBLIES..... 120
- 9.3 COMPRESSOR AND PARTS ASSEMBLY ..... 122
- 9.4 COOLING SYSTEM ..... 126
- 9.5 FRAME AND CANOPY (1 OF 2) ..... 128
- 9.6 FRAME AND CANOPY (2 OF 2) ..... 130
- 9.7 INSTRUMENT PANEL..... 132
- 9.8 GENERATORS AND PARTS ..... 136
- 9.9 ENGINE AND DRIVE PARTS..... 138
- 9.10 ELECTRICAL SYSTEM ..... 142
- 9.11 FUEL TANK ASSEMBLY ..... 144
- 9.12 AIR STORAGE ASSEMBLY ..... 146
- 9.13 DECAL AND PLATE LOCATIONS (1 OF 4)..... 148
- 9.13 DECAL AND PLATE LOCATIONS (2 OF 4)..... 150
- 9.13 DECAL AND PLATE LOCATIONS (3 OF 4)..... 152
- 9.13 DECAL AND PLATE LOCATIONS (4 OF 4)..... 154

**Continued on next page...**



**APPENDIX A: ADDITIONAL INFORMATION..... 157**

A.1	ELECTRIC MOTOR CHART - STARTING WATTS.....	157
A.2	EXTENSION CORD CHART.....	158
A.3	WATTAGE REQUIREMENTS FOR COMMON RECEPTACLE UNITS .....	159
A.4	AIR TOOL AIR CONSUMPTION CHART .....	160
A.5	AIR N ARC 300 SERIES ALL-IN-ONE POWER SYSTEM AVAILABLE OPTIONS LIST.....	161
A.6	HOSE INSTALLATION GUIDE.....	163

**APPENDIX B: INSTRUMENT PANEL FUNCTIONS ..... 165**

B.1	INSTRUMENT PANEL KEY FUNCTION MAP.....	165
	MACHINE PACKAGE ON/OFF OPERATION FUNCTIONS (B.2.~)	
B.2.1	INSTRUMENT PANEL - OFF FUNCTION .....	166
B.2.2	INSTRUMENT PANEL - KEY TO ON FUNCTION.....	167
B.2.3	INSTRUMENT PANEL - KEY TO START FUNCTION.....	168
B.2.4	INSTRUMENT PANEL - KEY TO RUN (ON) FUNCTION.....	169
	<b>COMPRESSOR MODE FUNCTIONS (B.3.~)</b>	
B.3.1	INSTRUMENT PANEL - COMPRESSOR OFF FUNCTION .....	170
B.3.2	INSTRUMENT PANEL - COMPRESSOR ON FUNCTION.....	171
	<b>DC WELDER/CHARGER MODE FUNCTIONS (B.4.~)</b>	
B.4.1	INSTRUMENT PANEL - WELDER/CHARGER OFF FUNCTION.....	172
B.4.2	INSTRUMENT PANEL - DC CHARGER (12V) FUNCTION.....	173
B.4.3	INSTRUMENT PANEL - DC CHARGER (12V BOOST) FUNCTION.....	174
B.4.4	INSTRUMENT PANEL - DC CHARGER (24V BOOST) FUNCTION.....	175
B.4.5	INSTRUMENT PANEL - WELDER CC FUNCTION.....	176
B.4.6	INSTRUMENT PANEL - WELDER CV FUNCTION .....	177
	<b>GENERATOR MODE FUNCTIONS (B.5.~)</b>	
B.5.1	INSTRUMENT PANEL - GENERATOR OFF FUNCTION .....	178
B.5.2	INSTRUMENT PANEL - GENERATOR ON FUNCTION.....	179

**APPENDIX C: MAINTENANCE AND SERVICE LOG .... 181**

C.1	GENERAL DESCRIPTION.....	181
C.2	MAINTENANCE AND SERVICE LOG .....	182

**BLANK PAGE**

# GLOSSARY: TERMS AND DEFINITIONS

---

---

## G.1 GENERAL TERMS AND DEFINITIONS

**Air/Oil Separator** - Coalescer element.

**CFM** - Cubic Feet per Minute.

**ft-lb** - Foot Pound (torque measurement).

**N.C.** - Normally closed.

**N.O.** - Normally open.

**RMA** - Return Material Authorization (number). This number is assigned by a service technician, and is needed for warranty claims.

**RPM** - Revolutions Per Minute.

**Speed Control** - Governor.

## G.2 WELDING TERMS AND DEFINITIONS

**Air Carbon Arc Cutting (CAC-A)** - A cutting process by which metals are melted by the heat of an arc using a carbon electrode. Molten metal is forced away from the cut by a blast of forced air.

**Alternating Current (AC)** - An electrical current that reverses its direction at regular intervals, such as 60 cycles alternating current (AC), or 60 hertz.

**Amperage** - The measurement of the amount of electricity flowing past a given point in a conductor per second. Current is another name for amperage.

**Arc** - The physical gap between the end of the electrode and the base metal. The physical gap causes heat due to resistance of current flow and arc rays.

**Constant Current (CC) Welding Machine** - These welding machines have limited maximum short circuit current, with consistent amperage regardless of the voltage output.

**Constant Voltage (CV) Welding Machine** - This type of welding machine output maintains a relatively stable, consistent voltage regardless of the amperage output. It results in a relatively flat volt-amp curve.

**Current** - Another name for amperage. The amount of electricity flowing past a point in a conductor every second.

**Direct Current (DC)** - Flows in one direction and does not reverse its direction of flow as alternating current does.

**Direct Current Electrode Negative (DCEN)** - The direction of current flow through a welding circuit when the electrode lead is connected to the negative terminal and the work lead is connected to the positive terminal of a DC welding machine. Also called direct current, straight polarity (DCSP).

**Direct Current Electrode Positive (DCEP)** - The direction of current flow through a welding circuit when the electrode lead is connected to a positive terminal and the work lead is connected to a negative terminal to a DC welding machine. Also called direct current, reverse polarity (DCRP).

**Duty Cycle** - The number of minutes out of a 10-minute time period an arc welding machine can be operated at maximum rated output. An example would be 60% duty cycle at 250 amps. This would mean that at 250 amps the welding machine can be used for 6

minutes and then must be allowed to cool with the fan motor running for 4 minutes.

**Flux Cored Arc Welding (FCAW)** - An arc welding process which melts and joins metals by heating them with an arc between a continuous, consumable electrode wire and the work. Shielding is obtained from a flux contained within the electrode core. Added shielding may or may not be provided from externally supplied gas or gas mixture.

**Hertz** - Hertz is often referred to as "cycles per second". In the United States, the frequency or directional change of alternating current is usually 60 hertz.

**KVA (Kilovolt-amperes)** - Kilovolt-amperes. The total volts times amps divided by 1,000, demanded by a welding power source from the primary power furnished by the utility company.

**KW (Kilowatts)** - Primary KW is the actual power used by the power source when it is producing its rated output. Secondary KW is the actual power output of the welding power source. Kilowatts are found by multiplying volts and amps and dividing by 1,000 and taking into account any power factor.

**Microprocessor** - One or more integrated circuits that can be programmed with stored instructions to perform a variety of functions.

**MIG Welding (GMAW or Gas Metal Arc Welding)** - Also referred to as solid wire welding. An arc welding process which joins metals by heating them with an arc. The arc is between a continuously fed filler metal (consumable) electrode and the work piece. Externally supplied gas or gas mixtures provide shielding.

**Open-Circuit Voltage (OCV)** - As the name implies, no current is flowing in the circuit because the circuit is open. The voltage is impressed upon the circuit, however, so that when the circuit is completed, the current will flow immediately.

**Plasma Arc Cutting** - An arc cutting process which severs metal by using a constricted arc to melt a small area of the

work. This process can cut all metals that conduct electricity.

**Pounds Per Square Inch (psi)** - A measurement equal to a mass or weight applied to one square inch of surface area.

**Rated Load** - The amperage and voltage the power source is designed to produce for a given specific duty cycle period. For example, 275 amps, 25 load volts, at 60% duty cycle.

**Stick Welding (SMAW or Shielded Metal Arc)** - An arc welding process which melts and joins metals by heating them with an arc, between a covered metal electrode and the work. Shielding gas is obtained from the electrode outer coating, often called flux. Filler metal is primarily obtained from the electrode core.

**TIG Welding (GTAW or Gas Tungsten Arc)** - Often called TIG welding (Tungsten Inert Gas), this welding process joins metals by heating them with a tungsten electrode which should not become part of the completed weld. Filler metal is sometimes used and argon inert gas or inert gas mixtures are used for shielding.

**Voltage** - The pressure or force that pushes the electrons through a conductor. Voltage does not flow, but causes amperage or current to flow. Voltage is sometimes termed electromotive force (EMF) or difference in potential.

**Voltage-Sensing Wire Feeder** - Feeder operates from arc voltage generated by welding power source.

**Wire Feed Speed** - Expressed in in/min or mm/s, and refers to the speed and amount of filler metal fed into a weld. Generally speaking the higher the wire feed speed, the higher the amperage.

## G.3 AIR COMPRESSOR TERMS AND DEFINITIONS

**Aftercoolers** - devices for removing the heat of compression of the air or gas after

compression is completed. They are one of the most effective means of removing moisture from compressed air.

**Air Receivers** - tanks into which the compressed air is discharged from the air compressor. Receivers help to eliminate pulsations in the discharge line and also act as storage capacity during intervals when the dean

**Air Regulator** - Used to control the amount of pressure received from the tank.

**Check Valve** - Ensures the air flows in one direction.

**Discharge Pressure** - This is the absolute pressure of the air at outlet (delivery) of a compressor.

**Free Air Delivery (FAD)** - Free air delivery is the volume of air delivered under the conditions of temperature and pressure existing at the compressor intake. This generally taken as 1.0332 kg/cm square abs & 15 degree Centigrade.

**Inlet Pressure** - This is the absolute pressure of the air at inlet (suction) to a compressor.

**Intercoolers** - devices for removing the heat of compression of the air or between consecutive stages of multistage air compressors.

**Line Pressure Gauge** - Reads amount of pressure in the air hose, which supplies the tool with air.

**Moisture Separators** - devices for collecting and removing moisture precipitated from the air or gas during the process of cooling.

**Piston** - Compresses the air by pulling air into the cylinder of the pump when it moves downward and the pushes the air out when it moves upward.

**Pressure Switch** - Stops the motor when the tank is full (cut out pressure) and starts the motor when the pressure falls to a specific setting (cut in pressure).

**PSIG** - pounds per square inch gauge

**Pump** - Part that compresses the air and pushes it into the tank.

**Reciprocating Air Compressors** - those in which each compressing element consists of a piston moving back and forth in a cylinder.

**Rotary Air Compressors** - those which utilize two inter-meshing helical rotors to trap a volume of air, then compress it to a higher pressure.

**Single Stage Air Compressors** - those in which compression from initial to final pressure is complete in a single step or stage.

**Tank** - Holds the compressed air until used by an air tool or for some other purpose.

**Tank Pressure Gauge** - Indicates amount of pressure in tank.

**Two Stage Air Compressors** - those in which compression from initial to final pressure is completed in two distinct steps or stages.

**BLANK PAGE**

# WARRANTY CLAIMS PROCEDURE

## CLAIMS PROCESS FOR WARRANTED VANAIR PARTS

This process must be used by owners of Vanair® equipment in situations where a warranted item needs repair or replacement under the terms of the purchase warranty. Do not return items to Vanair without prior authorization from the Vanair Warranty Administrator.

### PROCEDURE:

When a customer needs assistance in troubleshooting a system and/or returning parts, follow the steps below.

**1. Locate the machine's serial number:**

The machine package serial number plate is located inside the machine compartment on the floor near to the generator mounting and the engine oil drain tube outlet (see *Figure 1*).

**2. Fill out the Return Material Authorization Form's required information:**

Locate the form on **page XVI** of this Section. Follow the instructions given on the form to fill in the information needed. This form is used for the purpose of soliciting a warranty case. All of the field information **except** for the bottom section block fields, which include *Disposition of Goods*, *Notifications* and *Additional Notes*, will be required.

**3. Have a list of the symptoms/condition/malfunctions along with any applicable temperature and pressure readings, and also the number of operational hours available:**

The above information is needed in addition to the information from Step #2.

**4. Contact the Vanair Service Department by phone (1-219-879-5100) to speak with a Service Technician.**

**5. Vanair Service will troubleshoot the problem based on the information provided by the customer, and**

#### NOTE

The RMA number must be placed on the outside of the package being returned.

#### NOTE

All labor claims or invoices must be approved by the Vanair Warranty Administrator prior to starting repair work along with the cost of the repair. All paper work associated with the returned item and warranty repair cost must reference the RMA number issued against the part, and be forwarded to Vanair within 30 days of the completion of work.

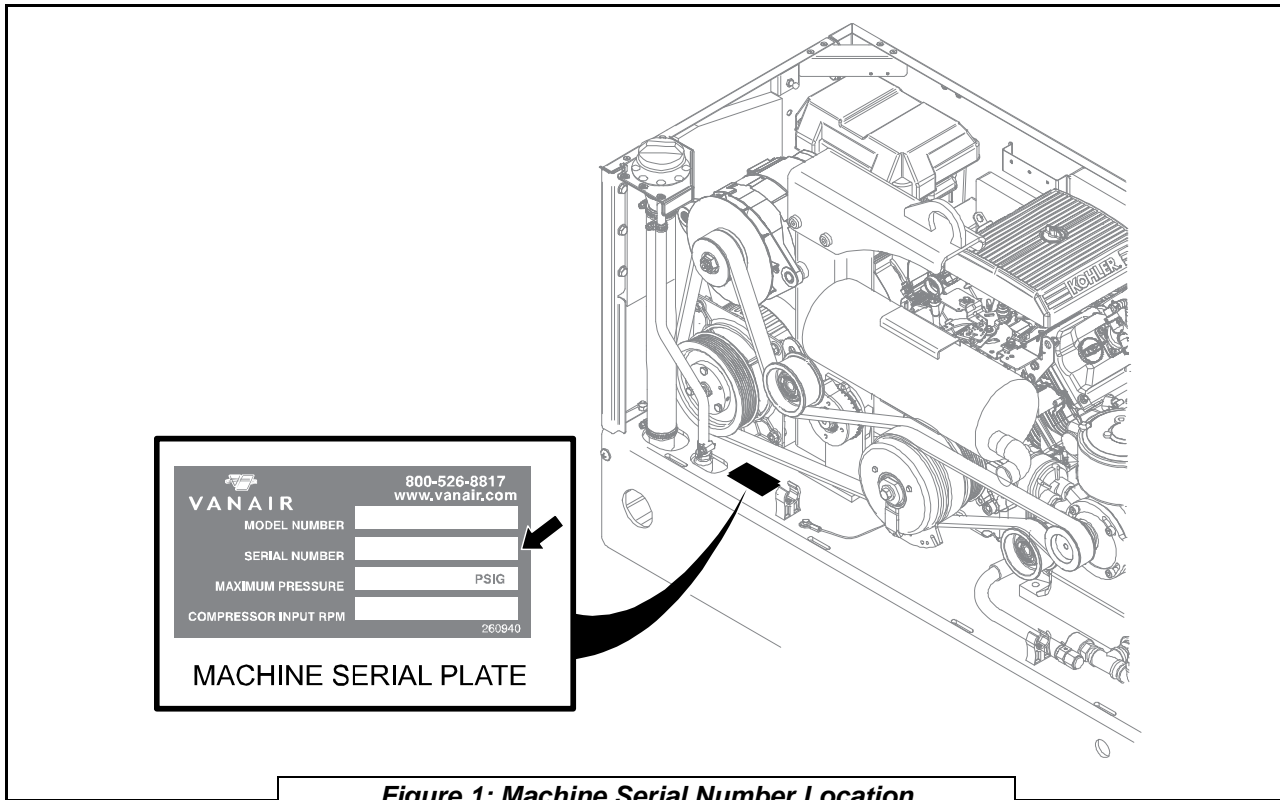

**Figure 1: Machine Serial Number Location**

attempt to return the unit to service as quickly as possible.

6. If the unit cannot be returned to service, and Vanair determines this matter is a warranty issue, the Service Technician will assign an RMA (Return Material Authorization) number that will provide for the return of the item to Vanair for analysis and a final determination as to the item’s warranty status.

Customers have 30 days after the RMA number is issued to return the item. If the part is not returned within this period, the RMA is void and any claims will be denied.

Before sending a warranty part to a customer, Vanair® will need a P.O. or credit card number to cover the cost of the part and shipping. After the part is analyzed and deemed to be covered under warranty, Vanair will issue credit to the customer. All parts eligible for warranty must have the RMA number on the invoice at the time of purchase.

No items can be returned “freight collect”. Freight costs will be addressed at the time the claim is closed. The customer pays any additional costs for warranty parts delivered through expedited services (i.e., Next Day, Second Day).



**VANAIR WILL NEVER ACCEPT ANY INVOICES FOR PARTS RETURNED: ANY PARTS RETURNED VIA INVOICE WILL BE RETURNED FREIGHT COLLECT: NO PARTS ARE TO BE RETURNED FREIGHT COLLECT!**

Vanair® Mfg., Inc. strives to continuously improve its customer service. Please forward any questions, comments, or suggestions to Vanair Service (219-879-5100) or e-mail us (service@vanair.com).

# RETURN MATERIAL AUTHORIZATION FORM



Ph. 219-879-5100  
 Fax. 219-879-5335  
 service@vanair.com

## Return Material Authorization

10896 W. 300 N.  
 Michigan City, IN 46360

S / N: 30 _____	Customer: _____	Date: _____
AnA S/N: _____	RMA#: _____	Contact: _____
Email: _____	Phone : _____	
Fax : _____	Address : _____	
Tech : _____	Dealer : _____	PO# : _____

### GENERAL INFORMATION

All returns are sent back for warranty consideration and are subject to factory inspection and analysis. Vanair® is not responsible for shipping damage due to insufficient or improper packaging methods. Failure to identify returned goods with the assigned RMA number on the outside of the shipping package will delay processing or result in the shipment being returned, freight collect. To receive warranty parts, a credit card or Purchase Order must be given to the service technician. Once the disposition of the part is determined, (I.E. manufacturing defect or other) Vanair will credit your account if covered by warranty. You can also contact the Service Department by email at service@vanair.com if you have any questions.

Return parts to the address listed above.

### INSTRUCTIONS TO CUSTOMERS

- 1 Product must be returned within 30 days from the day the RMA is issued. The RMA is void thereafter and any parts received after this time frame will be returned freight collect or not accepted.
- 2 The RMA number must be placed on the outside of the shipping package. Do not write the RMA number on the component with permanent marker, this damages the component. Please use a tag.
- 3 Components (including generators) must be returned completely assembled with no loose parts or they will not be accepted.
- 4 A copy of the form must be included with all paperwork.
- 5 No product will be accepted freight collect unless prior arrangements have been made.
- 6 We will not accept any parts returned on an invoice. They will be returned freight collect.
- 7 Any invoice issued for labor claims must include the RMA number assigned on this form, the 30-XXXXX number for the unit, and be invoiced for any labor claims within 30 days of the work completion. The allowable Vanair labor rate is \$65.00 per hour for all authorized work done in the United States.
- 8 All warranty claims must be pre-approved by Vanair or they will not be accepted.

Qty.	Part #	Description	Reason for return

Final Disposition of Goods		Notifications	Additional Notes
No Credit	Return to Customer	Quality Control	
Return to Stock	Issue Credit for Parts	Operations	
Scrap Goods	Issue Credit for Freight	Purchasing	
Ret to Vendor		Accounting	
Part Invoice #:		Shipping	

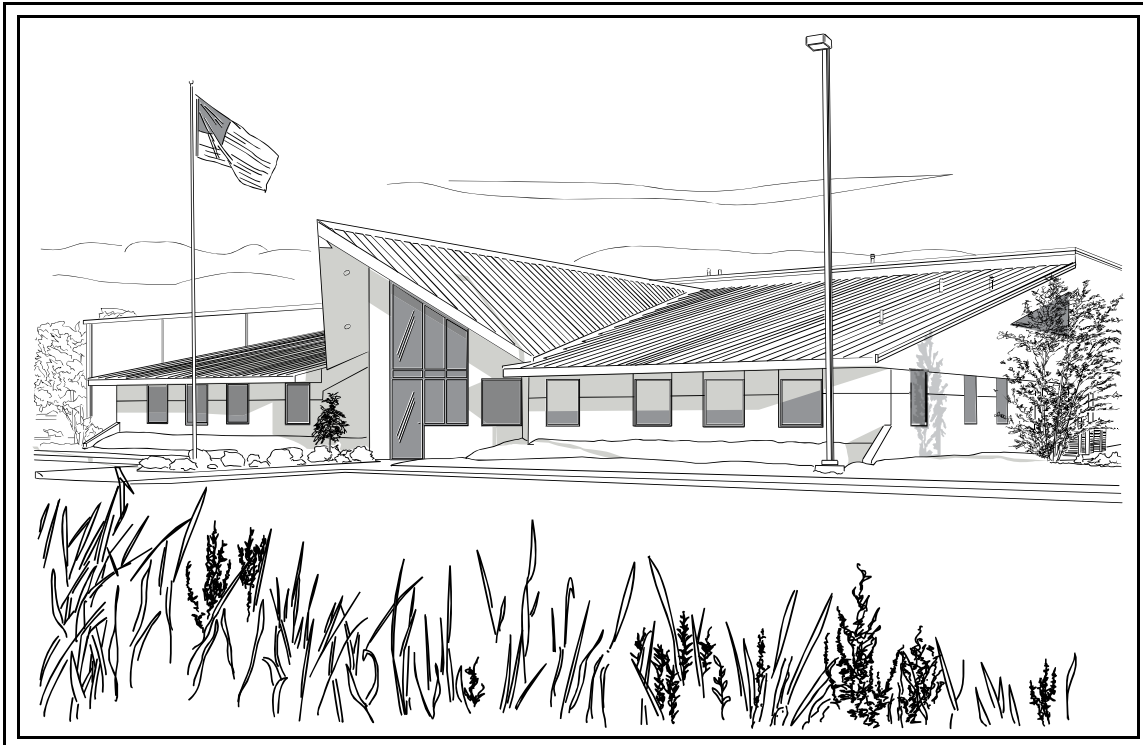

## EXPERIENCE THE VANAIR® AIR N ARC ALL-IN-ONE POWER SYSTEM ADVANTAGE!

The Air N Arc All-In-One Power System is designed to provide compressed air, DC welding output, AC power, and battery boosting/charging in one easy to use interface.

This unit is designed to operate in an industrial environment, and with proper maintenance it should provide years of reliable service. This unit is weather-proof and able to operate in temperature extremes ranging from -20°F to 110°F (see **Section 6.7, Extreme Condition Operation**).

The AC generator features a brushless, maintenance-free design, and is completely separate from the DC welding generator.

The All-In-One Power System can support a multi-user operation. However, simultaneously using any two functions to their maximum output will cause a drop in

### NOTE

Due to the caustic nature of “un-sealed” lead acid batteries Vanair® Mfg., Inc. does not recommend the use of this style of battery. Acid fumes can cause damage to the machine and void the warranty.

RPM of the engine. This RPM drop will reduce the voltage output of the AC generator, which can cause damage to power tools being used. The operator must monitor the AC voltage at all times to insure proper voltage output.

This publication contains the latest information available at the time of preparation. Every effort has been made to ensure accuracy. However, Vanair® Manufacturing, Inc. takes no responsibility for errors or consequential damages caused by reliance on the information contained herein.

Vanair Manufacturing, Inc. reserves the right to make design change modifications or improvements without prior notification.

# SECTION 1: SAFETY

## 1.1 GENERAL INFORMATION

The products provided by Vanair® Manufacturing, Inc., are designed and manufactured for safe operation and maintenance. But it is ultimately the responsibility of the users and maintainers for safe use of this equipment. Part of this responsibility is to read and be familiar with the contents of this manual before operation or performing maintenance actions.

## 1.2 DANGERS, WARNINGS, CAUTIONS, AND NOTES



### IMPORTANT



It is mandatory that all operators read this manual before operating or servicing the Air N Arc 300 Series All-In-One Power System. Failure to do so could result in death, bodily injury or damage to equipment.



### DANGER

Identifies actions or conditions which will cause death, severe injury, equipment damage or destructive malfunctions.



### WARNING

Identifies actions or conditions which may cause death, severe injury, equipment damage or destructive malfunctions.



### CAUTION

Identifies actions or conditions which will or can cause injuries, equipment damage or malfunctions.

### NOTE

Additional information (or existing information) which should be brought to the attention of operators/maintainers affecting safety, operation, maintenance, or warranty requirements.

## 1.3 INTERNATIONAL SAFETY SYMBOL

The symbols shown and defined in **Section 1: Safety** are used throughout this manual to call attention to and identify possible hazards.



The international warning symbol shown above is used on all decals, labels and signs that concern information pertaining to bodily harm. When you see the international warning symbol, **pay extremely careful attention**, and follow the given instructions or indications to avoid any possible hazard.

## 1.4 ARC WELDING HAZARDS

### 1.4.1 ⚠️ *ELECTRICAL SHOCK CAN KILL*



Touching live electrical parts can cause fatal shocks or severe burns. The electrode and work circuit is electrically live whenever the output is on. The input power circuit and machine internal circuits are also live when power is on. In semiautomatic or automatic wire welding, the wire, wire reel, drive roll housing, and all metal parts touching the welding wire are electrically live. Incorrectly installed or improperly grounded equipment is a hazard.

Do not touch live electrical parts.

Wear dry, hole-free insulating gloves and body protection.

Insulate yourself from work and ground using dry insulating mats or covers big enough to prevent any physical contact with the work or ground.

Do not use AC output in damp areas, if movement is confined, or if there is a danger of falling.

Additional safety precautions are required when working in electrically hazardous conditions such as in damp locations or while wearing wet clothing; on metal structures such as floors, gratings, or scaffolds; when in cramped positions such as sitting, kneeling, or lying; or when there is a high risk of unavoidable or accidental contact with the work piece or ground.

Do not work alone!

Disconnect input power or stop engine before installing or servicing this equipment. Lockout/tag out input power according to OSHA29 CFR1910.147 (see **Section 1.9, Principal Safety Standards**).

Properly install and ground this equipment according to its Owner's Manual and national, state, and local codes.

Always verify the supply ground: check and be sure that input power cord ground wire is properly connected to ground terminal in disconnect box or that cord plug is connected to a properly grounded receptacle outlet.

When making input connections, attach proper grounding conductor first and double-check connections.

Frequently inspect input power cord for damage or bare wiring; replace cord immediately if damaged—bare wiring can kill.

Turn off all equipment when not in use.

Do not use worn, damaged, undersized, or poorly spliced cables.

Do not drape cables over your body.

If earth grounding of the work piece is required, ground it directly with a separate cable.

Do not touch electrode if you are in contact with the work, ground, or another electrode from a different machine.

Use only well-maintained equipment. Repair or replace damaged parts at once. Maintain unit according to manual.

Do not touch electrode holders connected to two welding machines at the same time since double open-circuit voltage will be present.

Wear a safety harness if working above floor level.

Keep all panels and covers securely in place.

Clamp work cable with good metal-to-metal contact to work piece or work table as near the weld as practical.

Insulate work clamp when not connected to workpiece to prevent contact with any metal object.

Do not connect more than one electrode or work cable to any single weld output terminal.

### 1.4.2 *FUMES AND GASES CAN BE HAZARDOUS*

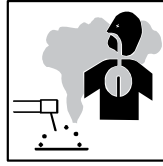

Welding produces fumes and gases. Breathing these fumes and gases can be hazardous to your health.

Keep your head out of the fumes. Do not breathe the fumes.

If inside, ventilate the area and/or use local forced ventilation at the arc to remove welding fumes and gases.

If ventilation is poor, wear an approved air-supplied respirator.

Read and understand the Material Safety Data Sheets (MSDS's) and the manufacturer's instructions for metals, consumables, coatings, cleaners, and degreasers.

Work in a confined space only if it is well ventilated, or while wearing an air-supplied respirator. Always have a trained watch person nearby.

Welding fumes and gases can displace air and lower the oxygen level causing injury or death. Be sure the breathing air is safe.

Do not weld in locations near degreasing, cleaning, or spraying operations.

The heat and rays of the arc can react with vapors to form highly toxic and irritating gases.

Do not weld on coated metals, such as galvanized, lead, or cadmium-plated steel, unless the coating is removed from the weld area, the area is well-ventilated, and while wearing an air-supplied respirator. The coatings and any metals containing these elements can give off toxic fumes if welded.

### 1.4.3 *BUILD UP OF GAS CAN INJURE OR KILL*

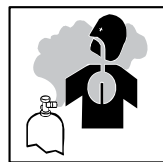

Shut off shielding gas supply when not in use.

Always ventilate confined spaces or use approved air-supplied respirator.



#### 1.4.4 **⚠** *ENCLOSED SPACES CAN CAUSE A BUILD-UP OF NOXIOUS FUMES AND OVERHEATING*

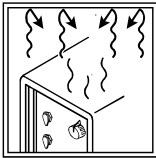

Do not use in enclosed spaces where deadly exhaust gases can build up and machine can overheat, causing fire.

#### 1.4.5 **⚠** *ARC RAYS CAN BURN EYES AND SKIN*

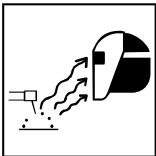

Arc rays from the welding process produce intense visible and invisible (ultraviolet and infrared) rays that can burn eyes and skin. Sparks fly off from the weld.

Wear an approved welding helmet fitted with a proper shade of filter lenses to protect your face and eyes from arc rays and sparks when welding or watching.

(See ANSI Z49.1 and Z87.1 listed in Safety Standards). Wear approved safety glasses with side shields under your helmet.

Use protective screens or barriers to protect others from flash, glare, and sparks; warn others not to watch the arc.

Wear protective clothing made from durable, flame-resistant material (leather, heavy cotton, or wool) and foot protection.

#### 1.4.6 **⚠** *WELDING CAN CAUSE FIRE AND EXPLOSION*



Welding on closed containers, such as tanks, drums, or pipes, can cause them to blow up. Sparks can fly off from the welding arc. The flying sparks, hot workpiece, and hot equipment can cause fires and burns. Accidental contact of electrode to metal objects can cause sparks, explosion, overheating, or fire. Check and be sure the area is safe before doing any welding.

Remove all flammables within 35 ft (10.7 m) of the welding arc. If this is not possible, tightly cover them with approved covers.

Do not weld where flying sparks can strike flammable material.

Protect yourself and others from flying sparks and hot metal.

Be alert that welding sparks and hot materials from welding can easily go through small cracks and openings to adjacent areas.

Watch for fire, and keep a fire extinguisher nearby.

Be aware that welding on a ceiling, floor, bulkhead, or partition can cause fire on the hidden side.

Do not weld on closed containers such as tanks, drums, or pipes, unless they are properly prepared according to AWSF4.1 (See **Section 1.9, Principal Safety Standards**).

Connect ground cable as close to the welding area as practical to prevent welding current from traveling long, possibly unknown paths and causing electric shock, sparks, and fire hazards.

Do not use welder to thaw frozen pipes.

Remove stick electrode from holder or cut off welding wire at contact tip when not in use.

Wear oil-free protective garments such as leather gloves, heavy shirt, cuffless trousers, boots, and a cap.

Remove any combustibles, such as a butane lighter or matches, from your person before doing any welding.

Follow requirements in OSHA1910.252 (a) (2) (iv) and NFPA 51B for hot work and have a fire watcher and extinguisher nearby.

#### 1.4.7 **FLYING METAL CAN INJURE EYES**

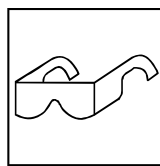

Sparks and flying metal can be caused by welding, chipping, wire brushing, and grinding. As welds cool, they can throw off slag.

Wear approved safety glasses with side shields even under your welding helmet.

**1.4.8 ⚠️ HOT PARTS CAN CAUSE SEVERE BURNS**

Do not touch hot parts bare handed.

Allow cooling period before working on equipment.

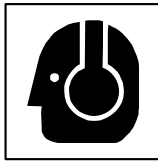
**1.4.9 ⚠️ NOISE CAN DAMAGE HEARING**

To handle hot parts, use proper tools and/or wear heavy, insulated welding gloves and clothing to prevent burns.

Noise from some processes or equipment can damage hearing.

Wear approved ear protection if noise level is high.

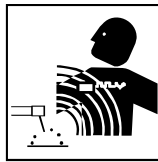
**1.4.10 ⚠️ MAGNETIC FIELDS CAN AFFECT PACEMAKERS**

Pacemaker wearers keep away.

Wearers should consult their doctor before going near arc welding, gouging, or spot welding operations.

Shielding gas cylinders contain gas under high pressure. If damaged, a cylinder can explode. Since gas cylinders are normally part of the welding process, be sure to treat them carefully.

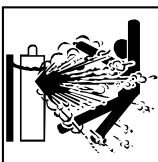
**1.4.11 ⚠️ CYLINDERS CAN EXPLODE IF DAMAGED**

Protect compressed gas cylinders from excessive heat, mechanical shocks, physical damage, slag, open flames, sparks, and arcs.

Install cylinders in an upright position by securing to a stationary support or cylinder rack to prevent falling or tipping.

Keep cylinders away from any welding or other electrical circuits.

Never drape a welding torch over a gas cylinder.

Never allow a welding electrode to touch any cylinder.

Never weld on a pressurized cylinder—explosion will result.

Use only correct shielding gas cylinders, regulators, hoses, and fittings designed for the specific application; maintain them and associated parts in good condition.

Turn face away from valve outlet when opening cylinder valve.

Keep protective cap in place over valve except when cylinder is in use or connected for use.

Use the right equipment, correct procedures, and sufficient number of persons to lift and move cylinders.

Read and follow instructions on compressed gas cylinders, associated equipment, and Compressed Gas Association (CGA) publication P-1 listed in Safety Standards.

## 1.5 ENGINE HAZARDS

### 1.5.1 BATTERY EXPLOSION CAN BLIND

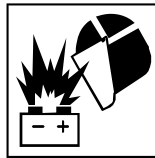

Always wear a face shield, rubber gloves, and protective clothing when working on a battery.

Stop engine before disconnecting or connecting battery cables or servicing battery.

Do not allow tools to cause sparks when working on a battery.

Do not use weld mode to charge batteries or jump start vehicles.

Observe correct polarity (+ and -) on batteries.

Disconnect negative (-) cable first and connect it last.

### 1.5.2 FUEL CAN CAUSE FIRE OR EXPLOSION

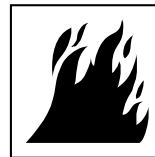

Stop engine and let it cool off before checking or adding fuel.

Always keep nozzle in contact with tank when fueling.

Do not add fuel while smoking or if unit is near any sparks or open flames.

Do not overfill tank—allow room for fuel to expand.

Do not spill fuel. If fuel is spilled, clean up before starting engine.

Dispose of rags in a fireproof container.

**1.5.3 ⚠ MOVING PARTS CAN CAUSE INJURY**

Keep away from fans, belts, and rotors. Keep all doors, panels, covers, and guards closed and securely in place.

Stop engine before installing or connecting unit.

Have only qualified people remove doors, panels, covers, or guards for maintenance and troubleshooting as necessary.

Disconnect negative (-) battery cable from battery to prevent accidental starting during servicing.

Keep hands, hair, loose clothing, and tools away from moving parts.

Reinstall doors, panels, covers, or guards when servicing is finished and before starting engine.

Before working on generator, remove spark plugs or injectors to keep engine from kicking back or starting.

Block flywheel so that it will not turn while working on generator components.

**1.5.4 ⚠ HOT PARTS CAN CAUSE SEVERE BURNS**

Do not touch hot parts bare handed.

Allow cooling period before working on equipment.

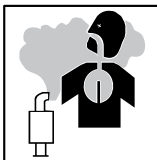
**1.5.5 ⚠ ENGINE EXHAUST GASES CAN KILL**

If used in a closed area, vent engine exhaust outside and away from any building air intakes.

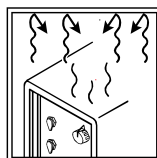
**1.5.6 ⚠ ENCLOSED SPACES CAN CAUSE A BUILD-UP OF NOXIOUS FUMES AND OVERHEATING**

Do not use in enclosed spaces where deadly exhaust gases can build up and machine can overheat, causing fire.

**1.5.7 ⚠ BATTERY ACID CAN BURN SKIN AND EYES**

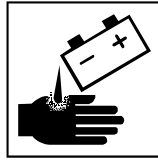

Do not tip battery.  
Replace damaged battery.  
Flush eyes and skin immediately with water.

**1.5.8 ⚠ ENGINE HEAT CAN CAUSE FIRE**



Do not locate unit on, over, or near combustible surfaces or flammables.  
Keep exhaust and exhaust pipes way from flammables.

**1.5.9 ⚠ EXHAUST SPARKS CAN CAUSE FIRE**



Use approved engine exhaust spark arrester in required areas — see applicable codes.

**1.6 COMPRESSED AIR HAZARDS**

**1.6.1 ⚠ BREATHING COMPRESSED AIR CAN CAUSE SERIOUS INJURY OR DEATH**

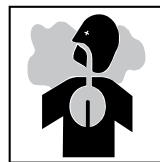

Do not use compressed air for breathing.  
Use only for cutting, gouging, and tools.

**1.6.2 ⚠ ENCLOSED SPACES CAN CAUSE A BUILD-UP OF NOXIOUS FUMES AND OVERHEATING**

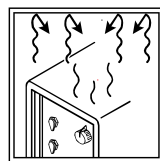

Do not use in enclosed spaces where deadly exhaust gases can build up and machine can overheat, causing fire.

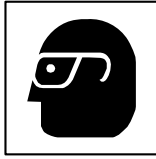
**1.6.3 ⚠ COMPRESSED AIR CAN CAUSE INJURY**

Wear approved safety goggles.

Do not direct air stream toward self or others.

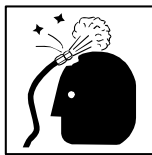
**1.6.4 ⚠ TRAPPED AIR PRESSURE AND WHIPPING HOSES CAN CAUSE INJURY**

Release air pressure from tools and system before servicing, adding or changing attachments, or opening compressor oil drain or oil fill cap.

**1.6.5 ⚠ HOT METAL FROM AIR ARC CUTTING AND GOUGING CAN CAUSE FIRE OR EXPLOSION**

Do not cut or gouge near flammables.

Watch for fire; keep extinguisher nearby.

**1.6.6 ⚠ HOT PARTS CAN CAUSE SEVERE BURNS**

Do not touch hot parts bare handed.

Allow cooling period before working on equipment.

**1.6.7 ⚠ READ INSTRUCTIONS**

Read Owner's Manual before using or servicing unit.

Stop engine and release air pressure before servicing.

Use only genuine Air-N-Arc replacement parts.

## 1.7 ADDITIONAL SYMBOLS FOR INSTALLATION, OPERATION AND MAINTENANCE

### 1.7.1 FALLING UNIT CAN CAUSE INJURY



Use lifting bail to lift unit and properly installed accessories only.

Lift and support unit only with proper equipment and correct procedures.

If using lift forks to move unit, be sure forks are long enough to extend beyond opposite side of unit.

### 1.7.2 OVERHEATING CAN DAMAGE MOTORS

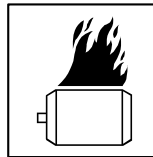

Turn off or unplug equipment before starting or stopping engine.

Do not let low voltage and frequency caused by low engine speed damage electric motors.

### 1.7.3 FLYING SPARKS CAN CAUSE INJURY

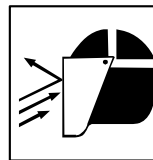

Wear a face shield to protect eyes and face.

Shape tungsten electrode only on grinder with proper guards in a safe location wearing proper face, hand, and body protection.

Sparks can cause fires—keep flammables away.

### 1.7.4 OVERUSE CAN CAUSE OVERHEATING

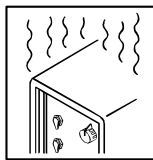

Allow cooling period; follow rated duty cycle.

Reduce current or reduce duty cycle before starting to weld again.

Do not block or filter airflow to unit.



### 1.7.5 **▲** *ENCLOSED SPACES CAN CAUSE A BUILD-UP OF NOXIOUS FUMES AND OVERHEATING*

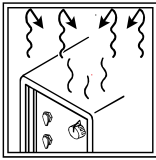

Do not use in enclosed spaces where deadly exhaust gases can build up and machine can overheat, causing fire.

### 1.7.6 **▲** *TILTING OF TRAILER CAN CAUSE INJURY*



Use tongue jack or blocks to support weight.

Properly install unit onto trailer according to instructions supplied with trailer.

### 1.7.7 **▲** *READ INSTRUCTIONS*



Use only genuine Air N Arc replacement parts.

Perform engine and air compressor (if applicable) maintenance and service according to this manual and the engine/air compressor (if applicable) manuals.

### 1.7.8 **▲** *H. F. RADIATION CAN CAUSE INTERFERENCE*



High-frequency (H.F.) can interfere with radio navigation, safety services, computers, and communications equipment.

Have only qualified persons familiar with electronic equipment perform this installation.

The user is responsible for having a qualified electrician promptly correct any interference problem resulting from the installation.

If notified by the FCC about interference, stop using the equipment at once.

Have the installation regularly checked and maintained.

Keep high-frequency source doors and panels tightly shut, keep spark gaps at correct setting, and use

grounding and shielding to minimize the possibility of interference.

### 1.7.9 **▲** *ARC WELDING CAN CAUSE INTERFERENCE*

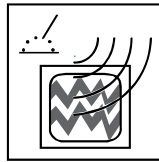

Electromagnetic energy can interfere with sensitive electronic equipment such as microprocessors, computers, and computer-driven equipment such as robots.

Be sure all equipment in the welding area is electromagnetically compatible.

To reduce possible interference, keep weld cables as short as possible, close together, and down low, such as on the floor.

Locate welding operation 100 meters from any sensitive electronic equipment.

Be sure this welding machine is installed and grounded according to this manual.

If interference still occurs, the user must take extra measures such as moving the welding machine, using shielded cables, using line filters, or shielding the work area.

## 1.8 **▲** CALIFORNIA PROPOSITION 65 WARNINGS

Welding or cutting equipment produces fumes or gases which contain chemicals known to the State of California to cause birth defects and, in some cases, cancer. (California Health & Safety Code Section 25249.5 et seq.)

Battery posts, terminals and related accessories contain lead and lead compounds, chemicals known to the State of California to cause cancer and birth defects or other reproductive harm. Wash hands after handling.

For Gasoline Engines: Engine exhaust contains chemicals known to the State of California to cause cancer, birth defects, or other reproductive harm.

For Diesel Engines: Diesel engine exhaust and some of its constituents are known to the State of California to cause cancer, birth defects, and other reproductive harm.

## 1.9 ▲ PRINCIPAL SAFETY STANDARDS

Safety in Welding, Cutting, and Allied Processes, ANSI Standard Z49.1, from Global Engineering Documents (phone: 1-877-413-5184, website:www.global.ihs.com).

Recommended Safe Practices for the Preparation for Welding and Cutting of Containers and Piping, American Welding Society Standard AWSF4.1, from Global Engineering Documents (phone: 1-877-413-5184, web site: www.global.ihs.com).

National Electrical Code, NFPA Standard 70, from National Fire Protection Association, P.O. Box 9101, 1 Battery March Park, Quincy, MA 02269-9101 (phone: 617-770-3000, web site: www.nfpa.org and www.sparky.org).

Safe Handling of Compressed Gases in Cylinders, CGA Pamphlet P-1, from Compressed Gas Association, 1735 Jefferson Davis Highway, Suite 1004, Arlington, VA 22202-4102 (phone: 703-412-0900, web site: www.cganet.com).

Code for Safety in Welding and Cutting, CSA Standard W117.2, from Canadian Standards Association, Standards Sales, 178 Rexdale Boulevard, Rexdale, Ontario, Canada M9W 1R3 (phone: 800-463-6727 or in Toronto 416-747-4044, web site: www.csainternational.org).

Practice For Occupational And Educational Eye And Face Protection, ANSI Standard Z87.1, from American National Standards Institute, 11West 42nd Street, New York, NY10036-8002 (phone: 212-642-4900, web site: www.ansi.org).

Standard for Fire Prevention During Welding, Cutting, and Other Hot Work, NFPA Standard 51B, from National Fire Protection

Association, P.O. Box 9101, 1 Battery March Park, Quincy, MA 02269-9101 (phone: 617-770-3000, web site: www.nfpa.org).

OSHA, Occupational Safety and Health Standards for General Industry, Title 29, Code of Federal Regulations (CFR), Part 1910, Subpart Q, and Part 1926, Subpart J, from U.S. Government Printing Office, Superintendent of Documents, P.O. Box 371954, Pittsburgh, PA 15250 (there are 10 Regional Offices; phone for Region 5, Chicago, is 312-353-2220, web site: www.osha.gov).

## 1.10 EMF INFORMATION

Considerations About Welding And The Effects Of Low Frequency Electric And Magnetic Fields Welding current, as it flows through welding cables, will cause electromagnetic fields.

There has been and still is some concern about such fields. However, after examining more than 500 studies spanning seventeen years of research, a special blue ribbon committee of the National Research Council concluded that: “The body of evidence, in the committee’s judgment, has not demonstrated that exposure to power-frequency electric and magnetic fields is a human-health hazard.” However, studies are still going forth and evidence continues to be examined. Until the final conclusions of the research are reached, you may wish to minimize your exposure to electromagnetic fields when welding or cutting.

To reduce magnetic fields in the workplace, use the following procedures:

1. Keep cables close together by twisting or taping them.
2. Arrange cables to one side and away from the operator.
3. Do not coil or drape cables around your body.
4. Keep welding power source and cables as far away from operator as possible.
5. Connect work clamp to workpiece as close to the weld as possible.

### **About Pacemakers:**

Pacemaker wearers consult your doctor before welding or going near welding operations. If cleared by your doctor, then following the above procedures is recommended.

## 1.11 MACHINE CANOPY ACCESS SAFETY SWITCHES

Consult *Figure 1-1*. The Air N Arc 300 Series machine package is equipped with two safety switches, which will either shut down, or not allow the machine to start, if access doors are bridged. The **hood safety switch** will not allow the machine to start if the hood is open; the hood must be closed in order to start the machine. However if the engine is running, the switch is bypassed,

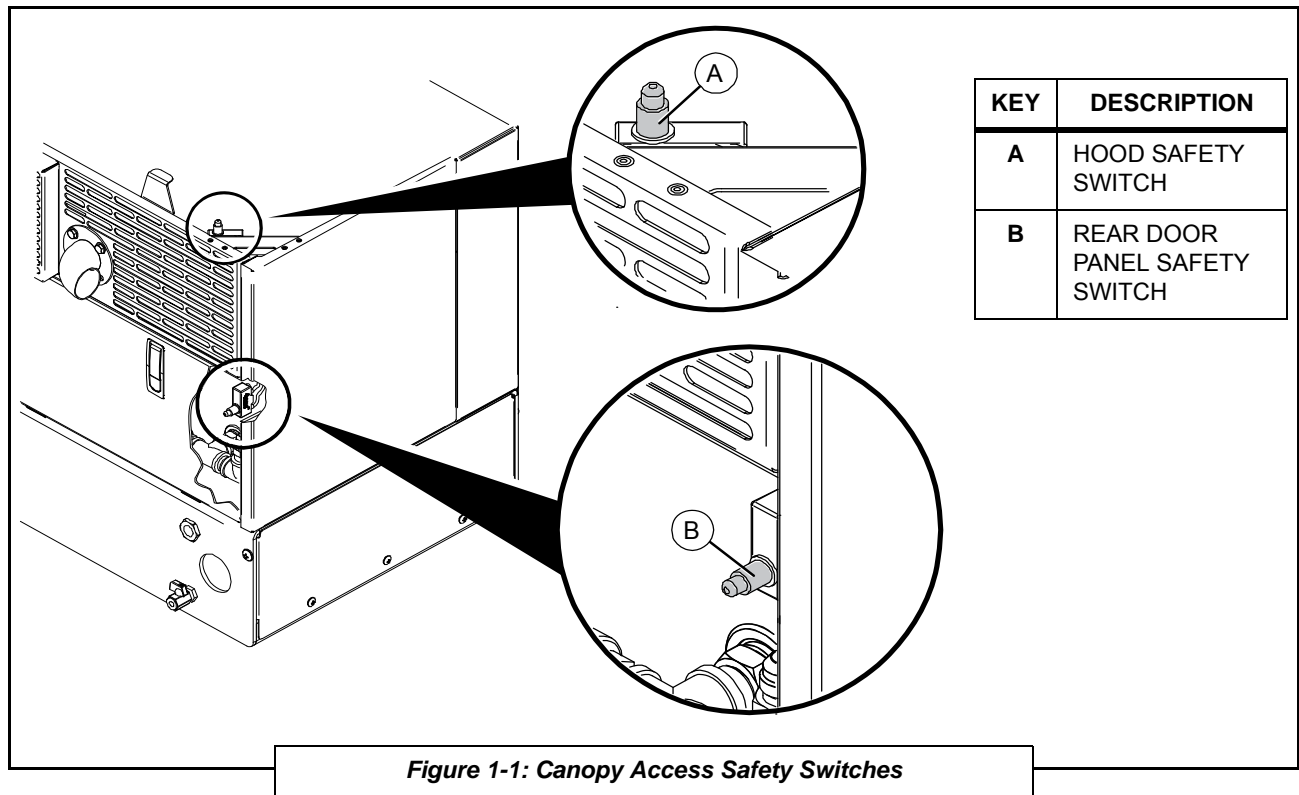

and the hood may be raised without detriment to the operating state of the machine.

 <b>CAUTION</b>
<p>The machine is not designed to run with the hood open as standard operating procedure. The safety switch bypass is designed to allow for observing machine components in operating condition.</p>

The rear door safety switch will not allow the machine to run if an attempt to open or remove the door panel occurs. Under condition of the machine running, if the switch is triggered, the machine will shut down.

## 1.12 DISPOSING OF MACHINE FLUIDS



Always dispose of machine fluids under the guidance of all applicable local, regional and/or federal law.

Vanair encourages recycling when allowed. For additional information, consult the container for information.



# SECTION 2: DESCRIPTION

## 2.1 GENERAL DESCRIPTION

Vanair® Manufacturing, Inc.'s Air N Arc 300 Series All-In-One Power System offers superior performance and reliability, as well as limited maintenance requirements.

The Power System package is designed to provide compressed air, DC welding output, AC power, and battery boosting/charging in one easy to use interface.

This section of the manual provides brief descriptions of the components and systems on the Air N Arc 300 Series All-In-One Power System package. See **Figure 2-1** for a quick visual guide to the Power System's main component locations.

## 2.2 COMPRESSED AIR SYSTEM

System Component or Component Group	Manual Section	Location
<b>COMPRESSED AIR SYSTEM</b>	<b>2.2</b>	<b>page 21</b>
Compressor Unit	2.2.1	page 21
Electronic Inlet Valve	2.2.2	page 22
Air Inlet Filter	2.2.3	page 22
Secondary Spin-on Air/Oil Coalescer	2.2.4	page 22
Minimum Pressure/Check Valve	2.2.5	page 23
Pressure Relief Valve	2.2.6	page 23
Adjustable Pressure Switch	2.2.7	page 23
Oil Reservoir and Primary Air/Oil Separator	2.2.8	page 24

### 2.2.1 COMPRESSOR UNIT

See **Figure 2-2**. The compressor is a single-stage, positive-displacement, oil-flooded, rotary screw type compressor. Rotary screw compressors function by injecting oil into the compressor unit and mixing it directly with the air as both air and oil are forced through the rotating screws in the compression chamber. Because of this concept, compressed air is generated on demand

### NOTE



**Read this manual before operating or servicing this equipment. Failure to comply with the operation and maintenance instructions in this manual WILL VOID THE EQUIPMENT WARRANTY.**

**This manual should be read in conjunction with other appropriate supplied manuals, such as the Engine Operator's manual, or Generator Operator's manual.**

### NOTE

**Refer to the Maintenance Section of this manual for adjustment and replacement procedures.**

### NOTE

**Refer to the provided Engine Operator's Manual for service and maintenance recommendations that are not provided in this manual.**

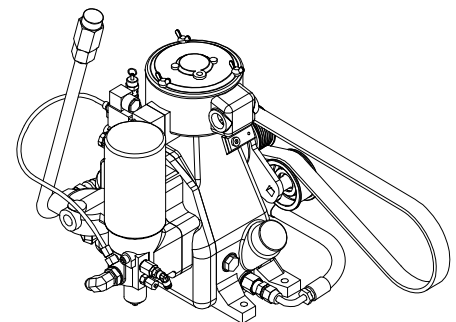

**Figure 2-2: Compressor Unit**

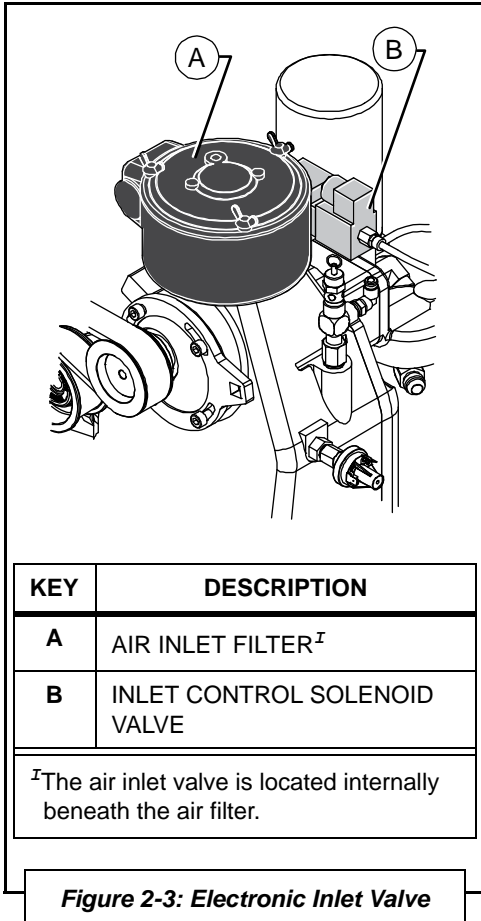

and eliminates the need for a separate air reservoir. Internal porting also lubricates the bearings and seals by using pressure differentials.

The oil has three primary functions: coolant, sealant, lubricant. The oil carries the heat associated with compressing air to an air-to-oil heat exchanger. It also seals the clearances between the rotors and the stator housing, as well as between the rotors themselves. Lastly, the oil lubricates the rotors and the bearings and seal, allowing one rotor to drive the other, which is an idler.

The rotors are mounted inside the main casting and consist of a male and female rotor supported with low-friction bearings sized for a long, useful life.

### 2.2.2 ELECTRONIC INLET VALVE

See **Figure 2-3**. The electronically-actuated inlet valve is a piston-type valve located directly on top of the compressor assembly, beneath the air inlet filter. On initial start-up, the solenoid is energized and the inlet valve opens due to pilot air being passed through the solenoid actuated valve. When operating pressure is reached, the pressure switch (**Figure 2-6**) de-activates the solenoid and the inlet valve closes. At the same time, the compressor pressure will unload to a lower pressure (typically about 40 psig). Only the compressed air within the compressor unit will reduce due to the operation of the minimum pressure/check valve. This reduction in internal air pressure reduces the power requirement considerably during this unloaded state. The pressure switch will re-activate the solenoid valve allowing the inlet valve to open upon sensing an air demand (reduced pressure). This will allow the compressor to start producing air again.

### 2.2.3 AIR INLET FILTER

See **Figure 2-3**. The air inlet filter that is integrated into the compressor assembly is a dry type replaceable element that drops in directly on top of the inlet valve assembly. It is accessible by removing the cover from the top of the compressor assembly. For routine maintenance of the air filter, consult **Sections 6.2** and **6.3** for maintenance schedules, and **Section 6.5.1** for specific air filter maintenance procedures.

### 2.2.4 SECONDARY SPIN-ON AIR/OIL COALESCER

See **Figure 2-4**. The compressor assembly is fitted with a secondary spin-on air/oil coalescer located on the top of the filter support housing on the rear of the compressor

**WARNING**

Compressor oil can ignite if it comes in contact with very hot surfaces, like a muffler or exhaust manifold on the engine.

**NOTE**

Refer to the Maintenance Section of this manual for adjustment and replacement procedures.



assembly. The coalescer element recovers the finer particles of residual oil that remain in the air after primary separation occurs. The oil that is collected in this element is “scavenged” back to the compressor unit for re-use. This element will need to be replaced from time to time as part of normal maintenance. For routine maintenance of the spin-on air/oil coalescer consult **Sections 6.2** and **6.3** for schedule intervals, and **Section 6.5.6** for the specific coalescer maintenance procedure.

**2.2.5 MINIMUM PRESSURE/CHECK VALVE**

See **Figure 2-4**. This combination valve is located on the underside of the filter support housing and serves two functions. First, the minimum pressure valve maintains a pressure of approximately 65 psig in the compressor to ensure oil injection during load conditions and also to maintain effective oil separation. Once this internal pressure is exceeded, it will allow air to pass downstream to the service outlet. The discharge check valve prevents air in the service line from venting down through the compressor during unload (when the compressor automatically relieves to 40 psig during non-use of the service air) and during shutdown.

**2.2.6 PRESSURE RELIEF VALVE**

See **Figure 2-5**. The pressure relief valve is the last safety device that will be activated. It is a spring-backed normally closed valve that will vent excess pressures to the atmosphere when excessive pressures are reached. The Air N Arc 300 Series Power System is equipped with a 200 psig relief valve. As the pressure begins to approach 200 psig, it will crack open to slowly relieve pressure. If pressure continues building through this venting, it will be fully open at 200 psig. Both air and oil will be expelled from this valve.

**2.2.7 ADJUSTABLE PRESSURE SWITCH**

See **Figure 2-6**. The adjustable pressure switch is mounted on the side of the battery support bracket and is plumbed into pressure on the upstream side of the minimum pressure valve. The purpose of the switch is to provide a control for the inlet valve control solenoid, much like a pneumatic regulator valve. When the pressure in the service line drops below the set limit, it reactivates the inlet valve control solenoid, allowing the inlet valve to suck in more air. The pressure switch has both a high and low pressure setting.

Although the pressure cut-in and cut-out pressures are pre-set at the factory, they may be manually adjusted.

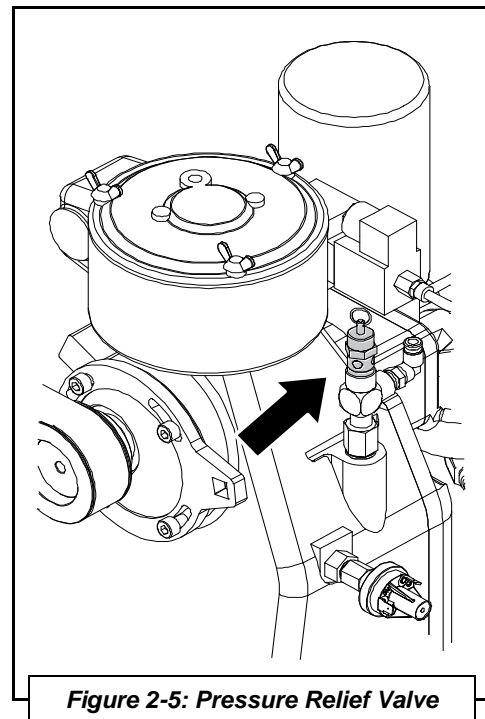
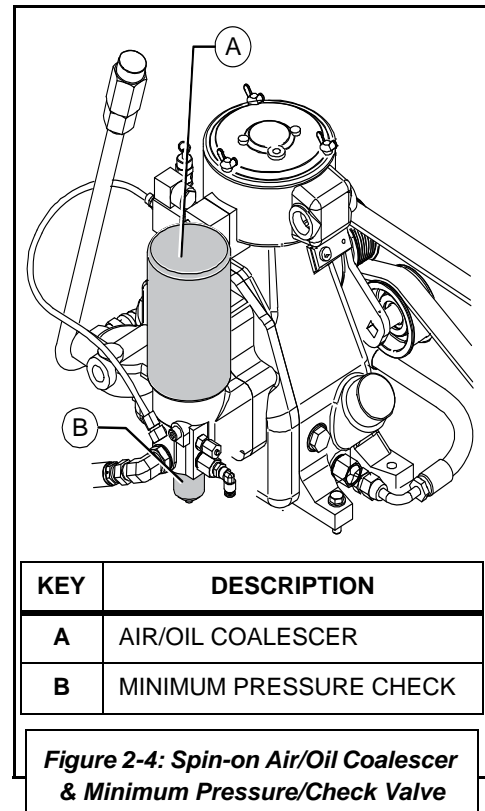

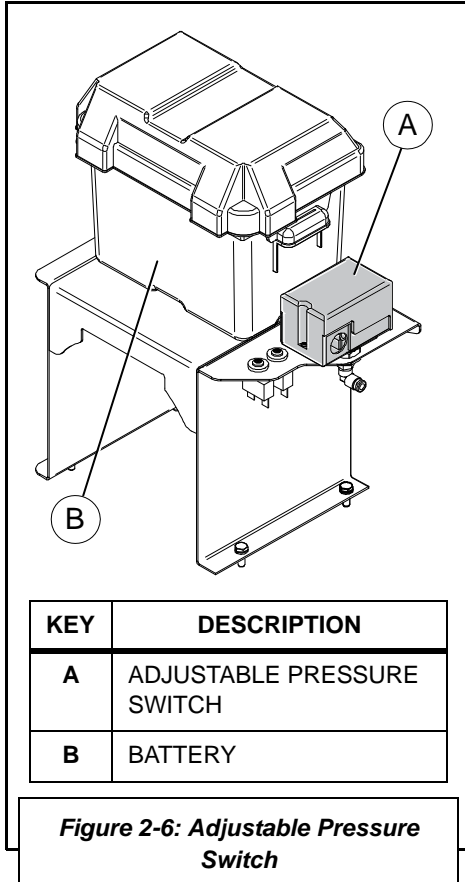

For procedure on pressure control switch adjustment, see **Section 6.5.15**.

### 2.2.8 OIL RESERVOIR AND PRIMARY AIR/OIL SEPARATOR

The main casting of the compressor unit, which contains the screw compressor, is also the oil reservoir and primary oil separation unit. The initial (primary) oil separation is caused by both changes in velocity and direction. The main casting also contains the oil fill tube and drain hose assembly. A separate oil reservoir is not required.

## 2.3 OIL COOLING SYSTEM

System Component or Component Group	Manual Section	Location
<b>OIL COOLING SYSTEM</b>	<b>2.3</b>	<b>page 24</b>
Fan Temperature Switch	2.3.1	page 24
Compressor Spin-on Oil Filter	2.3.2	page 25

See **Figure 2-7**. The oil cooling system is designed to provide cooling for the compressor lubricant. The cooling system also allows for the compressor lubricant temperature to be maintained to a minimum of approximately 160°F (71°C). The elevated temperature forces the moisture, which may be ingested into the compressor system due to atmospheric humidity, to stay in a state of vapor. This prevents the moisture from condensing out in the system and contaminating the lubricant.

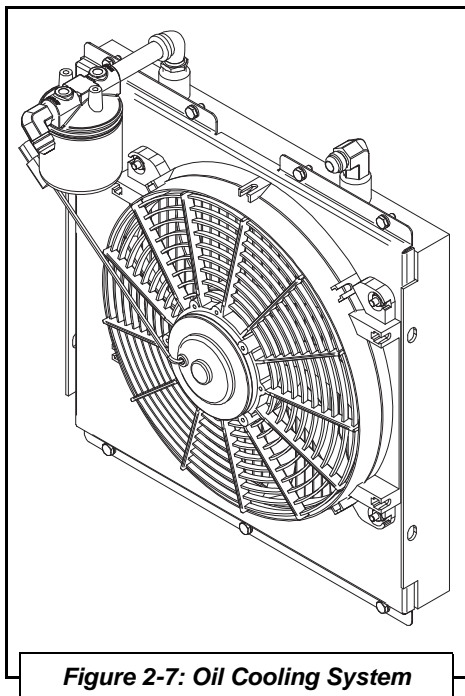

The cooler core for the 300 Series Power System relies on the cooling fan to suck fresh air from outside the package across the core to cool the compressor lubricant. The maximum lubricant temperature is maintained by using an electric fan temperature switch. This switch activates the cooling fan when it is required to cool the compressor lubricant. The fan temperature switches are set to turn on the fans at about 180°F (82°C). In addition, the fan will run to cool the enclosure when the enclosure's interior temperature reaches 100 °F (38°C).

The oil cooling system is composed of the following main components:

### 2.3.1 FAN TEMPERATURE SWITCHES

See **Figure 2-8**. The fan temperature switches are located as follows: the enclosure thermostat (100°F) on

the lower left side of the relay box, and the compressor oil temperature switch is found at the pipe tee coming off of the side of the compressor unit toward the bottom. The fan temperature switches activate and deactivate the cooling fan for the system to maintain proper lubricant operating temperatures.

### 2.3.2 COMPRESSOR SPIN-ON OIL FILTER

See **Figure 2-9**. The compressor system is also supplied with a spin-on oil filter, positioned off the top corner of the fan cooler. This element requires regular replacement to prolong the life of the compressor system. For routine maintenance of the spin-on filter, consult **Sections 6.2** and **6.3** for maintenance schedules, and **Section 6.5.4** for specific compressor oil filter maintenance procedures.

## 2.4 ENGINE

See **Figure 2-10**. The 300 Series All-In-One Power System utilizes the 29 HP EFI gas Kohler® engine, which features electronic fuel-injection, air-cooled, electric start with a fuel economy improvement up to 27%. It powers both the compressor unit and generators simultaneously. The engine has a full flow oil filter, while also offering re-borable and replaceable cylinders, grindable crankshaft, replaceable valve guides and seats, and heavy-duty engine bearings.

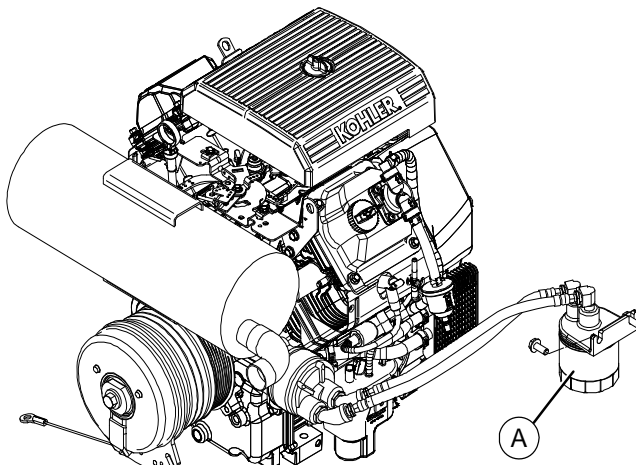

KEY	DESCRIPTION
A	ENGINE OIL FILTER (bracket is mounted to frame)

Figure 2-10: Engine

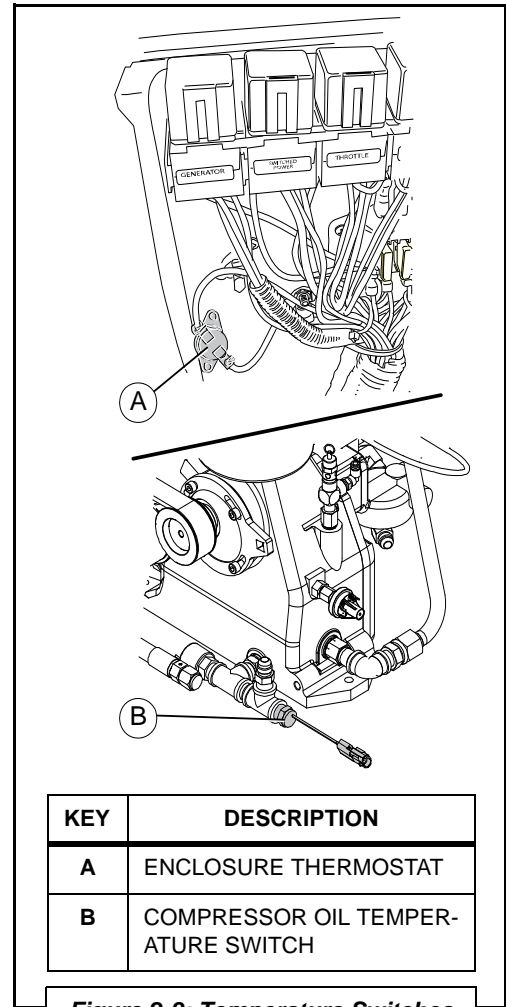

Figure 2-8: Temperature Switches

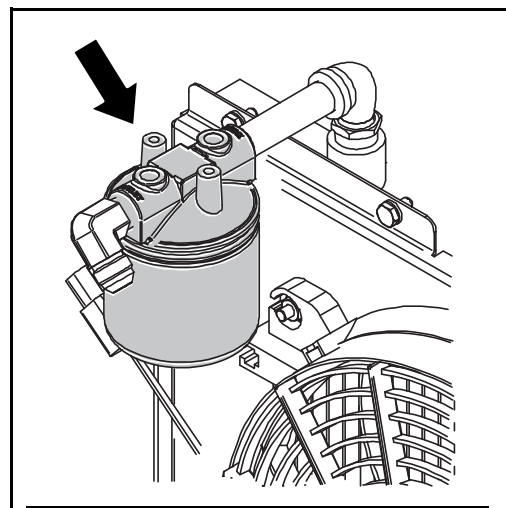
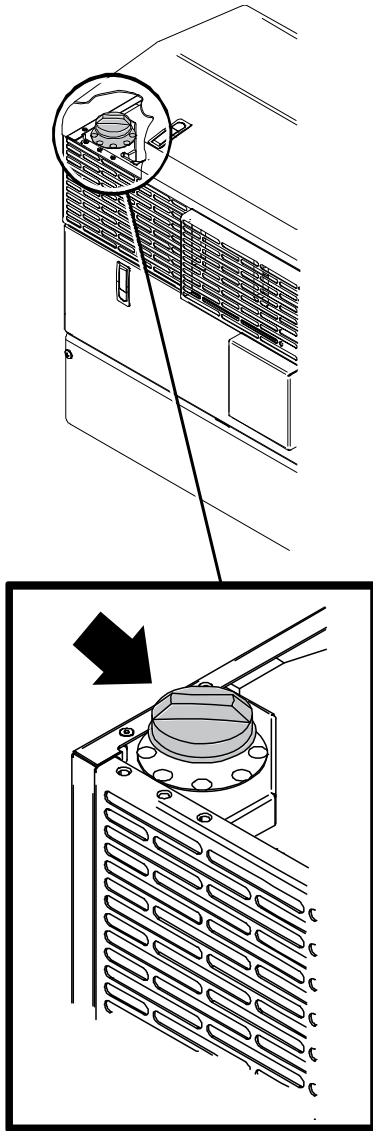

Figure 2-9: Compressor Spin-on Filter



**Figure 2-11: Fuel Fill Port Location**

### NOTE

Refer to the Engine Operator's Manual for service and maintenance recommendations that are not provided in this manual.

The engine is preset to a fixed speed. The adjustment for the engine can be attained by setting the speed adjustment screws. For procedure on setting the engine speed control, consult **Section 6.5.14**.

### NOTE

Do not tamper with the governor setting to increase the maximum engine speed. Overspeed is hazardous and will void the engine warranty. The maximum allowable high idle speed no load for these engines is 4200 RPM.

The drive systems from the engine to both the compressor and generator are accomplished with two micro V-belt systems. Both of these systems have provisions for belt tensioning, should the belts become stretched out over time.

The fuel tank provided in the 300 Series Power System has a capacity of twelve (12) gallons (45.4 L), and is accessed via a conveniently-located port for ease of refill. The filler cap is accessed on the generator side of the package from the left front corner, under the hood (**Figure 2-11**). The fuel system has a fuel supply and return connection on the top of the fuel tank. Fuel level can be checked on the fuel level gauge that is located on the instrument panel. The fuel level gauge receives its level signal from the fuel sender that is located in the fuel tank.

The fuel system contains two fuel filters (**Figure 2-12**). The primary (70 micron), and secondary (10 micron) that can be easily serviced, if necessary. The primary filter is located on the suction side of the fuel pump, and the secondary filter is located after the pump.

## 2.5 AC GENERATOR

See **Figure 2-13**. The AC generator utilized on the 300 Series package is a 2-pole, single phase, 2-bearing, brussels style. These units should not require maintenance since they do not have slip rings, nor slipping contacts. The end brackets are die-cast in a high resistance aluminum alloy, the shaft is C45 steel, and is

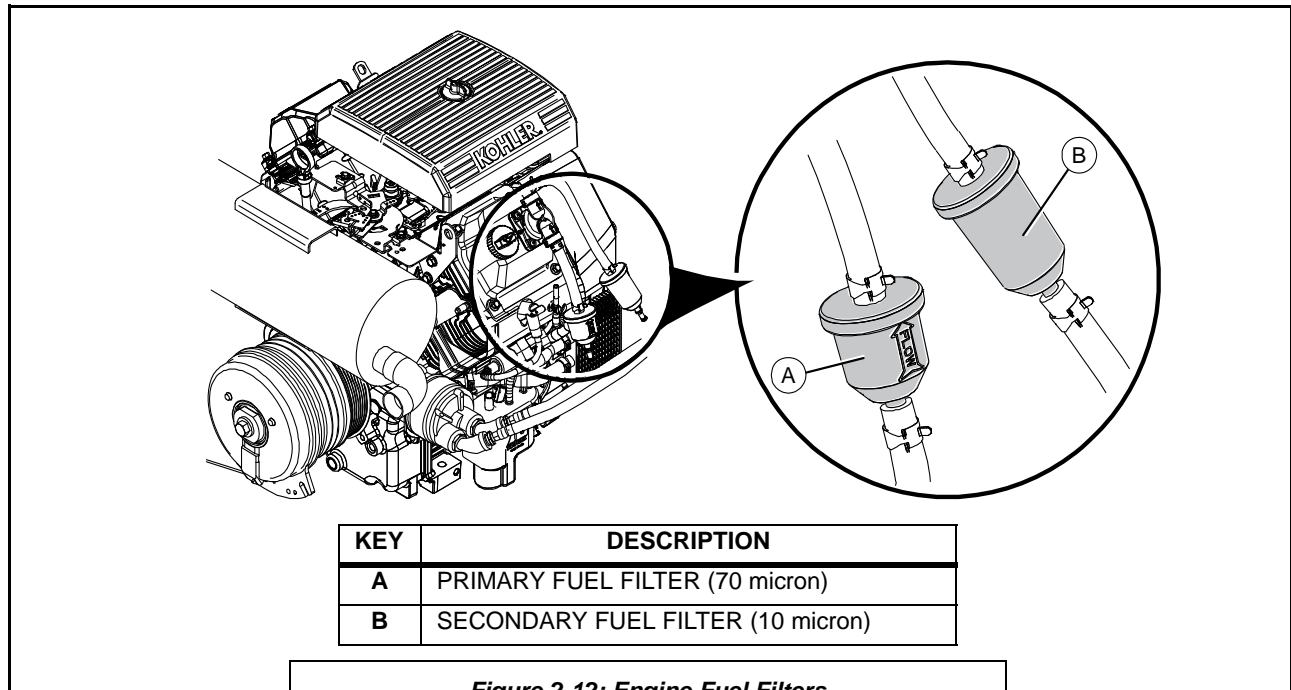

Figure 2-12: Engine Fuel Filters

fitted with a keyed fan.

## 2.6 INSTRUMENTATION

This section describes the basic functions of the controls located on the instrument panel. To insure that the controls are engaged correctly, Consult the various operating procedures as described in **Section 5, Operation**, and **Appendix B**.

System Component or Component Group	Manual Section	Location
<b>INSTRUMENTATION</b>	<b>2.6</b>	<b>page 27</b>
Volts/Amps Meter	2.6.1	page 28
Welder Function Switches	2.6.2	page 28
DC Charger Mode Toggle Switch	2.6.3	page 28
Volts/Amps Manual Adjustment Dial	2.6.4	page 28
Compressor ON/OFF Toggle Switch	2.6.5	page 30
Compressor Air Pressure Switch/ Gauge	2.6.6	page 30
Weld Lead Junction	2.6.7	page 30
Battery Cable Receptacle	2.6.8	page 30
Generator Control ON/OFF Toggle Switch	2.6.9	page 30

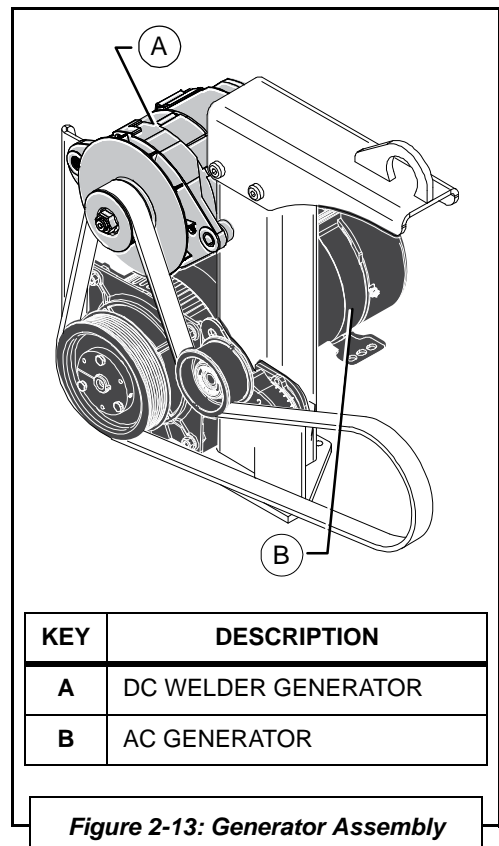

Figure 2-13: Generator Assembly

AC Voltage Outlets	2.6.10	page 30
Circuit Breaker Overload Trip/Reset Buttons	2.6.11	page 30
Engine Control (ON/OFF/START) Switch	2.6.12	page 31
Fuel Gauge/Hour Meter	2.6.13	page 31

See **Figure 2-14**. The standard instrument panel for the Air N Arc 300 Series contains a volts/amps meter, welder function switches (welder CC/CV toggle switch, and DC charger/welder toggle switch), welder DC charge switch, volt/amp manual adjustment dial, compressor ON/OFF switch, air pressure gauge, fuel gauge/hour meter, weld lead terminals, battery cable receptacle, generator control ON/OFF switch, AC voltage outlets, AC overload trip/reset buttons, and a fuel/hour meter gauge. In addition, the panel contains function indicator lamps that light to show various machine operation conditions.

### 2.6.1 VOLTS/AMPS METER

The **volts/amps meter** shows the amount of volts and/or amp level while welding or boosting.

### 2.6.2 WELDER FUNCTION SWITCHES

The **constant current (CC) or constant voltage (CV) toggle switch** lets the operator choose the type of power supply desired.

- CC Mode = Constant Amperage
- CV Mode = Constant Voltage

The three-position **DC charger/welder toggle switch** serves as the battery charge enabling switch, power-enabling switch for welding, or the disabling (OFF) switch for the welding function.

### 2.6.3 DC CHARGER MODE TOGGLE SWITCH

The three-position **DC charger mode toggle switch** lets the operator choose the type of charge needed from 12V center (default), 12V boost or 24V boost options. This is a momentary switch; the lights will indicate the mode selected.

### 2.6.4 VOLTS/AMPS MANUAL ADJUSTMENT DIAL

The **volts/amps manual adjustment dial** allows the operate to manually increase or decrease the amount of

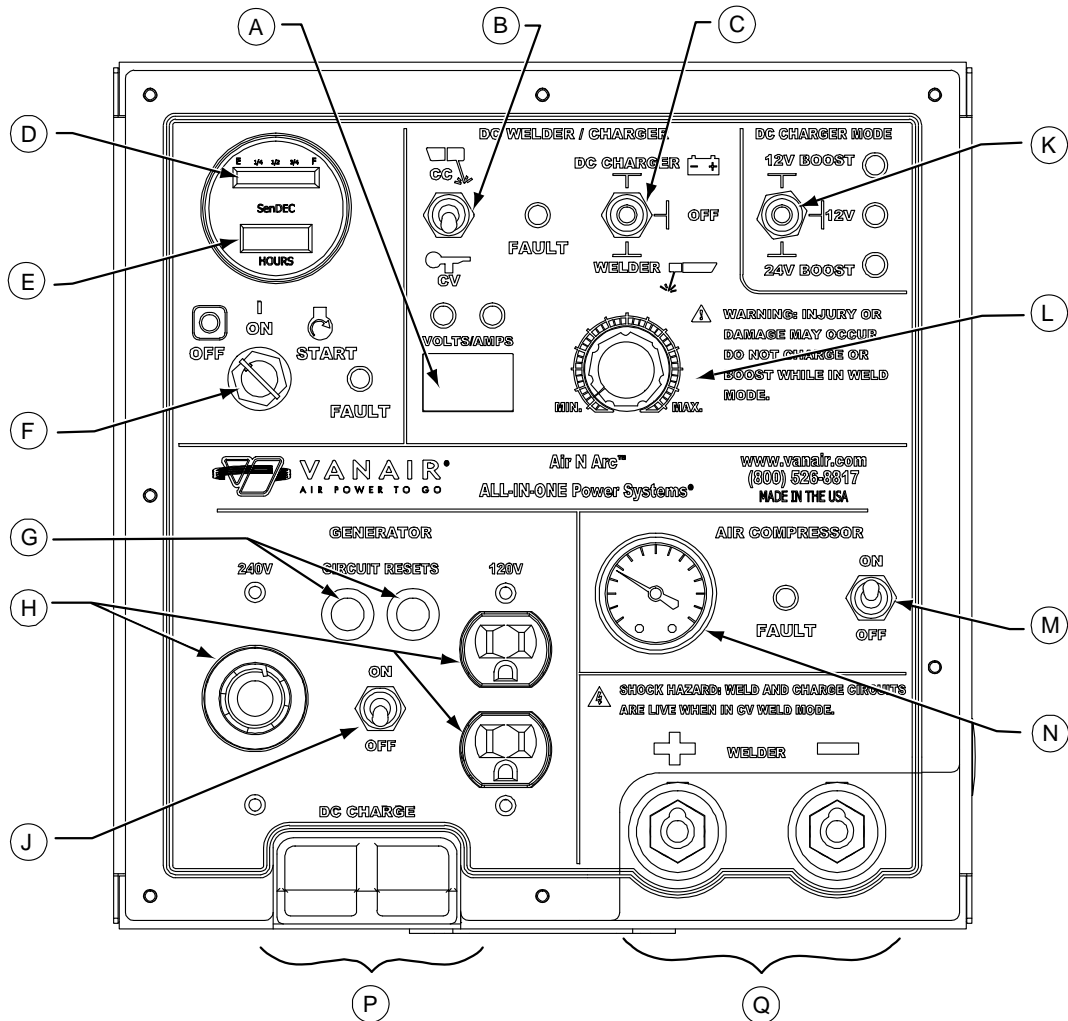

KEY	DESCRIPTION	KEY	DESCRIPTION
A	VOLTS/AMPS METER (2.6.1)	J	GENERATOR CONTROL ON/OFF SWITCH (2.6.9)
B	WELDER CC/CV TOGGLE SWITCH (2.6.2)	K	DC CHARGER 12V / 24V TOGGLE SWITCH (2.6.3)
C	DC CHARGER/WELDER TOGGLE SWITCH (2.6.2)	L	VOLTS/AMPS MANUAL ADJUSTMENT DIAL (2.6.4)
D	FUEL GAUGE (2.6.13)	M	COMPRESSOR ON/OFF SWITCH (2.6.5)
E	HOUR METER (2.6.13)	N	AIR PRESSURE GAUGE (2.6.6)
F	ENGINE CONTROL (ON/OFF/START SWITCH) (2.6.12)	P	BATTERY CABLE RECEPTACLE (2.6.8)
G	CIRCUIT BREAKER TRIP/RESET BUTTONS (2.6.11)	Q	WELDER LEAD CONNECTION (2.6.7)
H	AC VOLTAGE OUTLETS (2.6.10)		

Figure 2-14: Instrument Panel

amperage or voltage, in variable increments, for the desired weld heat.

### ***2.6.5 COMPRESSOR ON/OFF TOGGLE SWITCH***

The **compressor ON/OFF toggle switch** engages the air compressor system. This machine utilizes an electronic clutch to engage the compressor.

### ***2.6.6 COMPRESSOR AIR PRESSURE SWITCH/ GAUGE***

The **compressor air pressure switch/gauge** indicates the discharge air pressure.

### ***2.6.7 WELDER LEAD CONNECTION***

The **welder lead connection** contains the positive and negative interface connections for the standard welding lead cable.

### ***2.6.8 BATTERY CABLE RECEPTACLE***

The **battery cable receptacle** junction contains the interface connections for the battery cables when charging the battery from the DC charger. The battery cable receptacle contains a weather-resistant cap.

### ***2.6.9 GENERATOR CONTROL ON/OFF TOGGLE SWITCH***

The **generator control ON/OFF switch** engages the AC generator. When off, the outlets are de-energized.

### ***2.6.10 AC VOLTAGE OUTLETS***

The **AC voltage outlets** allow for AC Generator power access via two 120V, and one 240V receptacles.

### ***2.6.11 CIRCUIT BREAKER OVERLOAD TRIP/ RESET BUTTONS***

The **reset-capable circuit breakers** are used to protect the generator circuits from damage if an overload or short circuit situation occurs. The circuit breaker will trip and can be easily reset by pushing the button.

**Do not** force the reset buttons if they remain fixed in their inset positions—if the buttons are tripping frequently, or do not reset, this is an indication of a system problem. Whenever a circuit breaker trips, always check the complete system for any possible faulty conditions before resetting the system. If trouble persists, consult **Section 7, Troubleshooting**, or the Vanair® Service Department.



### 2.6.12 ENGINE CONTROL (ON/OFF/START) SWITCH

The **engine control switch** engages the phases of the engine, which is integral to all the functions of the 300 Series Power System. Consult the various operating procedures as found in **Section 4, Operation**, to determine the integration of the engine with each separate system function.

### 2.6.13 FUEL GAUGE/HOUR METER

The **fuel gauge/hour meter** contains two separate system indications: the fuel gauge shows the amount of fuel, and the hour meter records the total accumulated hours that the package is operated. The hour meter can be used to assist in scheduled maintenance planning.

<b>NOTE</b>
<b>Any time the engine control switch is on, the hour meter is running.</b>

**BLANK PAGE**

# SECTION 3: SPECIFICATIONS

TABLE 3A: WELDER, GENERATOR, AND ENGINE SPECIFICATIONS	
SYSTEM INFORMATION	SPECIFICATION
Rated Welder Output	300A High Frequency DC/CC, DC/CV; 100% Duty Cycle @ 280 Amps
Welding Leads	25 or 50 Ft Optional (Refer to Section A.5 for Optional Parts Listing)
AC Generator	6800 Watts Continuous Duty
AC Generator 120V Power Rating	60 Hz 1 PH, 2-20 Amp Circuits
AC Generator 240V Power Rating	60 Hz 1 PH, 28 Amp
Battery Charger Capacity	12V Charge, 12V Boost, 24V Boost
Engine	29 EFI <sup>I</sup>
Engine Oil Capacity	Two (2) Quarts 10W30 (Refer to Engine Operator's Manual for Extreme Conditions)
Fuel Consumption	1.25 GPH at Full Engine Speed/Load 9.6 Hour Runtime w/ 12 Gallon Tank
Fuel Tank Capacity	12 Gallons
Fuel Type	87 Octane or Higher Unleaded Gasoline <sup>II</sup>
Operating Temperature Limits	-20°F to 110°F
<sup>I</sup> For in-depth specifications and requirements regarding the Kohler® 29 EFI engine, refer to the Engine Operator's Manual.	
<sup>II</sup> Ethanol blended fuels, such as E85, are prohibited for use with the Kohler 29 EFI engine. <b>DO NOT</b> use ethanol-based fuels.	

TABLE 3B: SPECIFICATIONS — AIR COMPRESSOR	
COMPRESSOR INFORMATION	SPECIFICATION
Compressor Type	Single Stage, Oil Injected Rotary Screw
Air Compressor Capacity	40 CFM @ 175 PSI
Inlet Control	Zero (0) No Load / 100% Load
Air Filter	Pleated Paper, Dry Type
Oil Filter	70 micron Spin-on Type
Oil Capacity/Type	<b>New:</b> 3 Quarts / <b>Service:</b> 2 Quarts Vanguard™ Premium Synthetic Oil
Air Tank Capacity	Four (4) Gallons
Tank Pressure Rating	200 PSI
Safety Relief Valve Setting	200 PSI
Operating Range (ambient)	-40° to 110°F (-12° to 43°C)
Electrical System	12 VDC
Cooling System	Air to Oil Heat Exchanger
Instrument Gauges	Pressure and Hour Meter
Adjustable Air Pressure Control Settings	Cut-in Pressure: 100 PSI / Cut-out Pressure: 125 PSI (Factory Preset); 150/175 PSI (Maximum Cut-out)
Air Service Outlets	One (1) on Control Panel, One (1) on Machine

**TABLE 3C: SPECIFICATIONS — UNIT WEIGHT AND DIMENSIONS<sup>I</sup>**

Dimensions	Length	Width	Height	Weight* (wet)	Weight (dry)
Overall Package	47.5"	22.5"	31"	780 lbs.	699 lbs.

<sup>I</sup>See **Diagram 4.5** (parts 1 and 2) for full dimension drawing, and **Figure 4-1** for location space requirements.

**TABLE 3D: BOLT AND TORQUE SPECIFICATIONS**

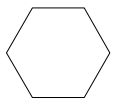
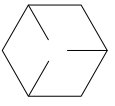
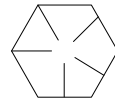
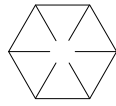
	 SAE 2	 SAE 5	 SAE 7	 SAE 8	
	2	5	7	8	SOCKET HEAD CAP SCREW
I.D. Marks	No markings	3 lines	5 lines	6 lines	Allen head
Material	Low carbon	Medium -carbon, tempered	Medium - carbon, quenched & tempered	Medium carbon, quenched & tempered	High-carbon, quenched & tempered
Tensile strength (minimum)	74,000 psi	120,000 psi	133,000 psi	150,000 psi	160,000 psi

**US BOLT TORQUE SPECIFICATIONS (Torque in foot-pounds)**

Bolt Diameter	Thread per inch	2		5		7		8		Socket head cap screw	
		Dry	Oiled	Dry	Oiled	Dry	Oiled	Dry	Oiled	Dry	Oiled
1/4	20	4	3	8	6	10	8	12	9	14	11
1/4	28	6	4	10	17	12	9	14	10	16	13
5/16	18	9	7	17	13	21	16	25	18	29	23
5/16	24	12	9	19	14	24	18	29	20	33	26
3/8	16	16	12	30	23	40	30	45	35	49	39
3/8	24	22	16	35	25	45	35	50	40	54	44
7/16	14	24	17	50	35	60	45	70	55	76	61
7/16	20	34	26	55	40	70	50	80	60	85	68
1/2	13	38	31	75	55	95	70	110	80	113	90
1/2	20	52	42	90	65	100	80	120	90	126	100
9/16	12	52	42	110	80	135	100	150	110	163	130
9/16	18	71	57	120	90	150	110	170	130	181	144
5/8	11	98	78	150	110	140	140	220	170	230	184
3/4	10	157	121	260	200	320	240	380	280	400	320
3/4	16	180	133	300	220	360	280	420	320	440	350
7/8	9	210	160	430	320	520	400	600	460	640	510
7/8	14	230	177	470	360	580	440	660	500	700	560
1	8	320	240	640	480	800	600	900	680	980	780
1	12	350	265	710	530	860	666	990	740	1060	845

<b>TABLE 3E: VARIOUS FUNCTION ACCEPTABLE TESTING OUTPUT RANGES</b>	
<b>FUNCTION</b>	<b>ACCEPTABLE RANGE</b>
Engine No-Load Hi RPM	3660+/-10
Engine Idle RPM	1660+/-10 // 670+/-20
Air Cut-in pressure	100+/-5
Air Cut-out pressure	125+/-10
AC generator Hz (no load)	61+/-1
AC generator 240 plug	243+/-3
AC generator 120 plug	122+/-2
AC generator 120 plug	122+/-2
Welder Max Voltage	70+/-10
Welder Min Voltage	20+/-5
Welder Max Amperage	300+/-5
Welder Max CV Voltage	40+/-2
Welder Min CV Voltage	14+/-2
Welder 12V charge voltage	14+/-1
Welder 12V boost voltage	16+/-1
Welder 24V boost voltage	29+/-1

<b>TABLE 3F: GENUINE VANGUARD™ OIL CHARACTERISTICS</b>	
<b>Viscosity</b>	178 SUS at 100°F (38°C)
<b>Flashpoint</b>	495°F (257°C)
<b>Pour point</b>	-49°F (-45°C)
<b>Contains</b>	Rust and Oxidation Inhibitors
<b>Contains</b>	Detergents

**BLANK PAGE**

# SECTION 4: INSTALLATION

## 4.1 MACHINE PACKAGE RECEIPT/ INSPECTION

Upon receipt of the machine package, inspect the exterior of the shipping crate for signs of shipping/transit damage. Any damage should be reported immediately to the shipping company. Open the lid and inspect the component parts and supports to ensure that there has been no internal movements of assemblies or components which may have caused damage. To install the 300 Series All-In-One Power System, refer to the following sections:

System Component or Part Group Task	Manual Section	Location
Machine Package Prep	4.2	page 37
Service Body Prep	4.3	page 37
Machine Package Mounting	4.4	page 39
Installation and Dimensions Diagram (Part 1 of 2)	4.5	page 42
Installation and Dimensions Diagram (Part 2 of 2)	4.5	page 43

## 4.2 MACHINE PACKAGE PREP

Refer to *Figure 4-1* and *Section 4.5, Installation and Dimensions Diagram*, and the following instructions.

1. Remove packing and inspect the machine and control panel for shipping damage.
2. Check fluid levels, if needed. Refer to *Section 6.5.3* for compressor oil, and *Section 6.5.13* for engine oil.

## 4.3 SERVICE BODY PREP

Consult *Section 3, Specifications* for dimension requirements, and the following instructions.

 **DANGER**

DO NOT install in enclosed spaces.

 **WARNING**

**ELECTRICAL HAZARD!** Be sure the battery is disconnected before starting the installation.

### NOTE

Contact Vanair at  
(219) 879-5100 / (800) 526-8817  
Service Fax: (219) 879-5335  
[www.vanair.com](http://www.vanair.com)  
to report missing items, incorrect part numbers, or other discrepancies.

### NOTE

Install electrical components (circuit breakers, pressure switches, toggle switches, etc.) in locations where exposure to water or moisture will be most minimized.

### NOTE

In order to prevent accidental damage to vehicle components (fuel tanks, lines, brake lines, wiring harnesses), note their location before drilling any holes.

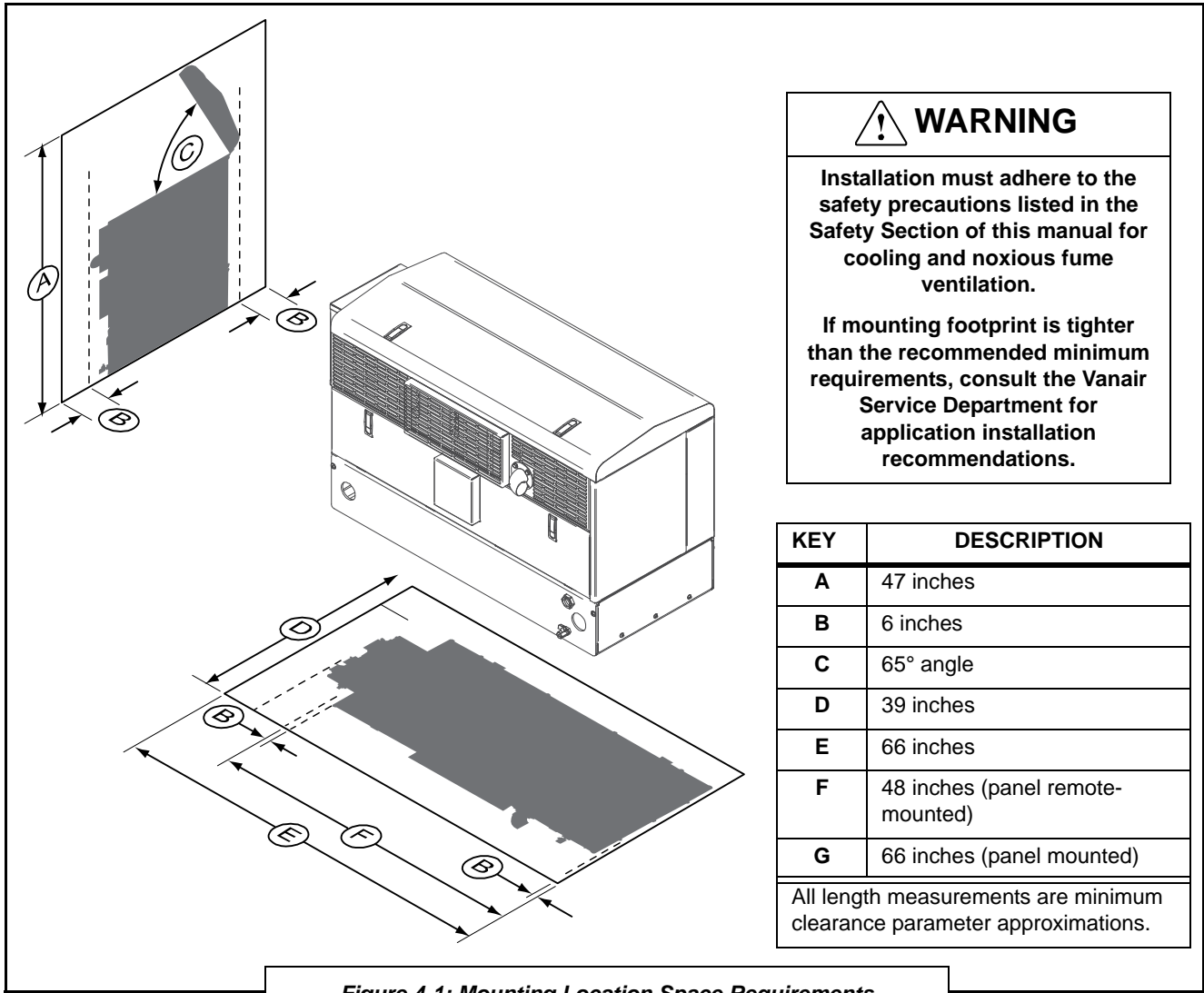

**Figure 4-1: Mounting Location Space Requirements**

**NOTE**

For set ups without a fuel tank where an additional fuel pump is required, order either of the following kits:

- Kit no. 032744 - Option for remote fuel pump short run
- Kit no. 032745 - Option for remote fuel pump long run

1. Drill four (4) 9/16” mounting holes in the service body floor on a 19.25” by 44.375” square pattern at the desired mounting location. Ensure that all proper machine clearances will be maintained.
2. For units without a fuel tank, follow these steps:
  - Mount the electric fuel pump at the desired location on the service body keeping it as close to the truck fuel tank as possible. Mount the electric fuel pump a maximum distance of 24 inches from the bottom of the tank (**Figure 4-2**).
  - Install 1/4” fuel line from the vehicle tank to the 1/4” fuel filter under the hood of the machine.



- Ensure that the lines do not make contact with sharp edges, moving parts or exhaust heat (consult **Appendix A, Section A.6 Hose Installation Guide** for assistance in running hose lines).
  - Units must have a 70 micron fuel filter in line before the pump.
3. Install the remote control panel (Optional) at the desired location on the service body and route the control trunk line to the location where the unit will mount. Ensure that all sharp edges that the trunk-line contacts are shielded or grommeted, and that there are no excessively sharp bends in the trunk-line. Ensure the trunk line does not come in contact with exhaust parts.

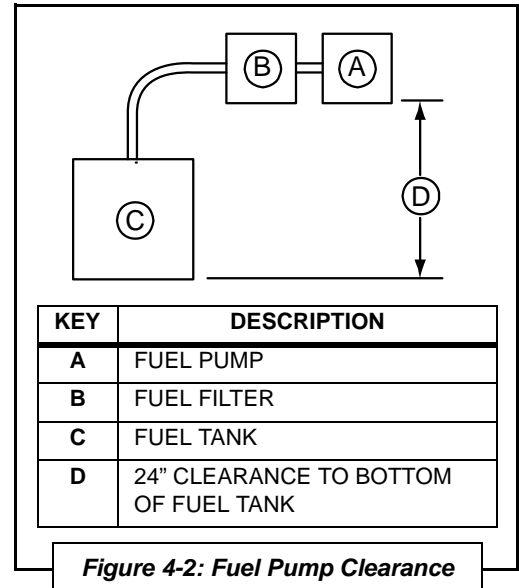

### 4.4 MACHINE PACKAGE MOUNTING

When determining package position on vehicle, be aware of the minimum space requirements needed for cooling and circulation requirements, and also package access for performing maintenance (see **Figure 4-1**, and **Diagrams 4.5** and **4.6**).

1. Refer to **Figure 4-4**. Remove the truss screws [B], nylon flat washers [C] in order to remove access panel covers ([A] and [K]) found on both side ends of the unit.

**NOTE**

Mounting brackets are available to space panel off from truck body (**Figure 4-3**). Contact Vanair.

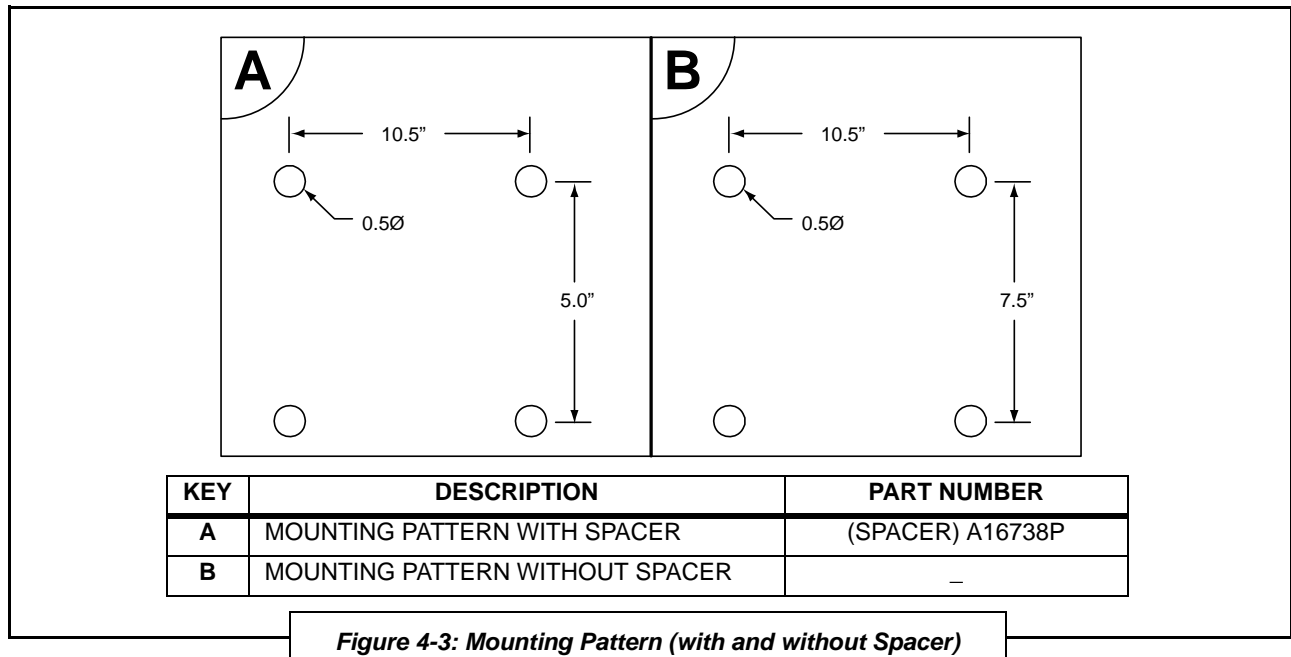

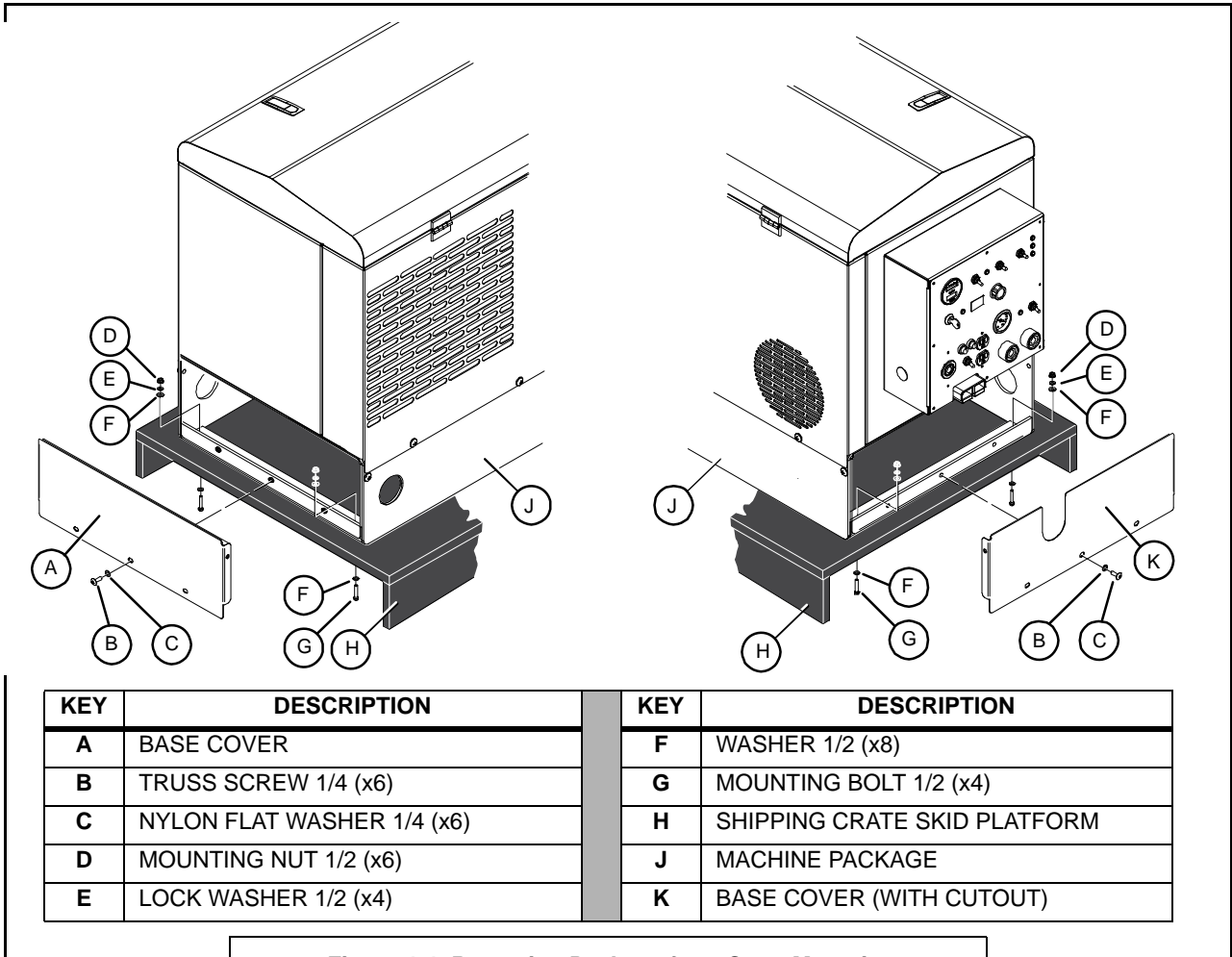
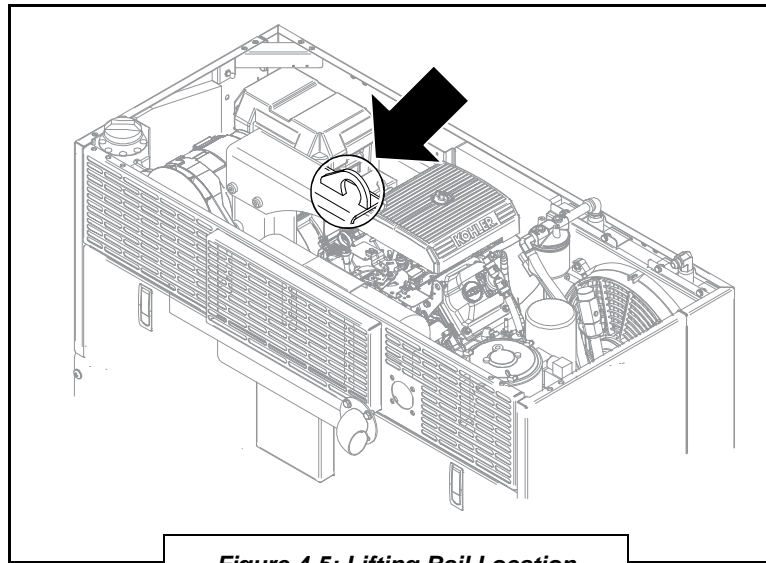

Figure 4-4: Removing Package from Crate Mounting

**CAUTION**

Lift the machine package in accordance within the safety guidelines given in Section 1.7.1, Falling Unit Can Cause Injury.

- To unbolt the unit from the skid, remove the mounting nuts [D], lock washers [E], washers [F] and mounting bolts [G] securing the package unit [J] to the shipping crate.
- Place the unit in a preliminary position on the service body so that the front panel access and hood opening (front) side is easily accessible, and the control trunk line and all other connections will reach the unit. Refer to **Figure 4-5** for lifting bail location.
- Route the control trunk-line through the grommated opening. Connect the 1/2" air line via the JIC fitting on the end of the air tank, and connect and secure the weather proof connectors. The plugs are all differentiated to ensure that they cannot be mis-connected.
- Connect and clamp the fuel line to the inline fuel filter located on the engine near the left



**Figure 4-5: Lifting Bail Location**

- valve cover as you are looking at the motor, if using truck tank.
6. Leaving the unit in the preliminary position, connect the ground cable to the unit battery, check all fluid levels. Replace the front access panel and close the unit hood.
  7. Turn the Ignition switch on the control panel to "ON". The hood should be opened while the ON sequence is initiated to check that the fuel pump is energized. Wait 3-5 seconds for the fuel pump to prime the fuel system. The unit will start more quickly if the fuel pump is manually pre-energized to prime the fuel system. Start and run the unit for a few minutes, then turn the machine off. Check fuel connections for leaks, verify all connections, and replace access panel and close hood.
  8. Move the unit into its final location for mounting, while positioning the control trunk line and all other connections.
  9. Bolt the machine down with four ½" bolts inserted from the bottom. See **Figures 4-1** and **Diagram 4.5** for location (**Diagram 4.5** shows mounting hole footprint as well).
  10. Start the unit and fully test all functions. Warm the unit to full operating temperature. After the unit has cooled, check all fluid levels and add as needed.

### NOTE

For guidance on machine start-up procedure and control panel functions, consult **Section 5, Operation** and **Appendix B**.

### NOTE

For safety reasons the front access panel and hood contain shut-off switches. The front access panel will not allow the machine to start if it is not in place, and will shut down the machine if it is removed while running. The machine will also not start if the hood is open. However, the machine will continue to run if the hood is opened while the machine is running. Consult **Section 1.11, Machine Canopy Access Safety Switches** for further information on the machine safety switches.

### NOTE

It is recommended that the machine be mounted on a vibration isolating material such as 1/4" neoprene rubber pads.

Isolating Dampeners (Part Number PR93969) are available by calling the Vanair® Customer Service Department.

### 4.5 INSTALLATION AND DIMENSIONS DIAGRAM (PART 1 OF 2)

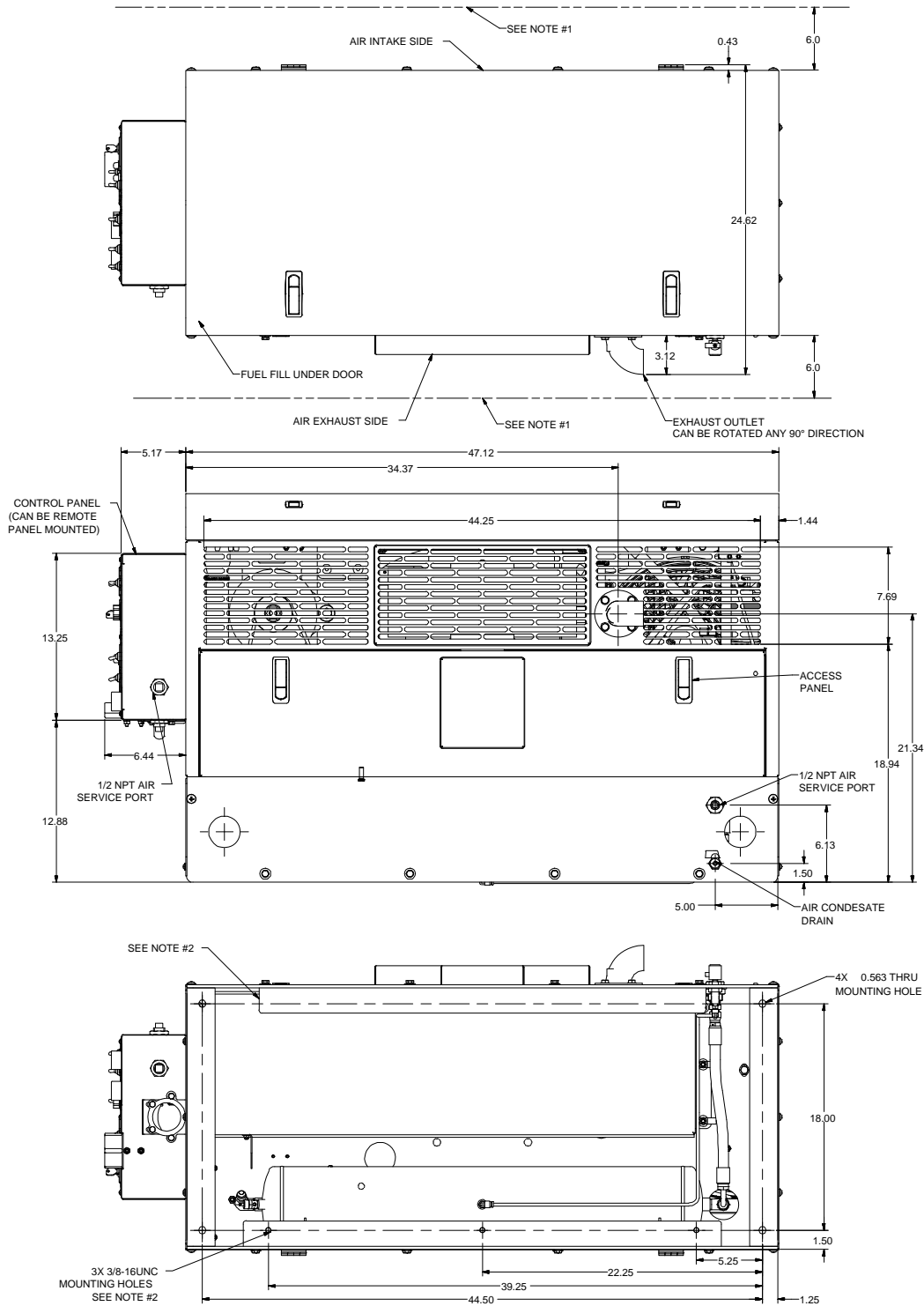

- NOTES:**
1. MINIMUM DIMENSIONS FOR PROPER VENTING.
  2. MOUNTING ANGLES (IF EQUIPPED).

050518\_r2

### 4.5 INSTALLATION AND DIMENSIONS DIAGRAM (PART 2 OF 2)

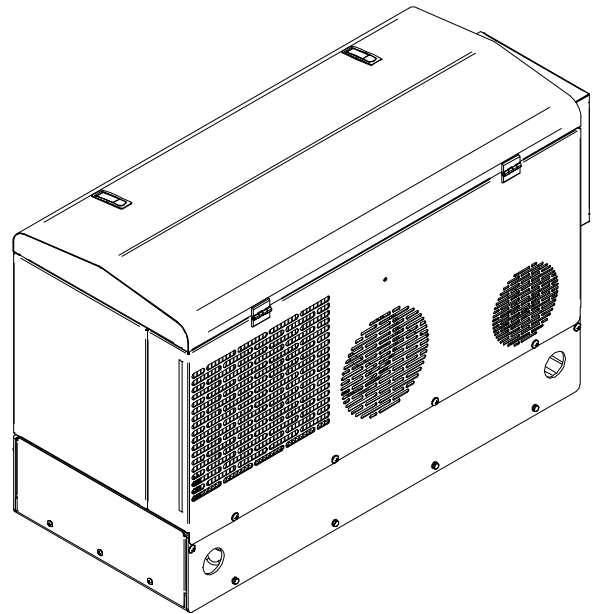
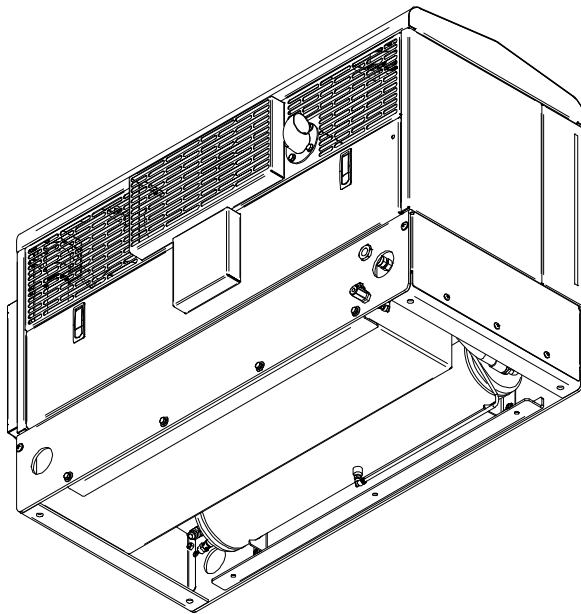
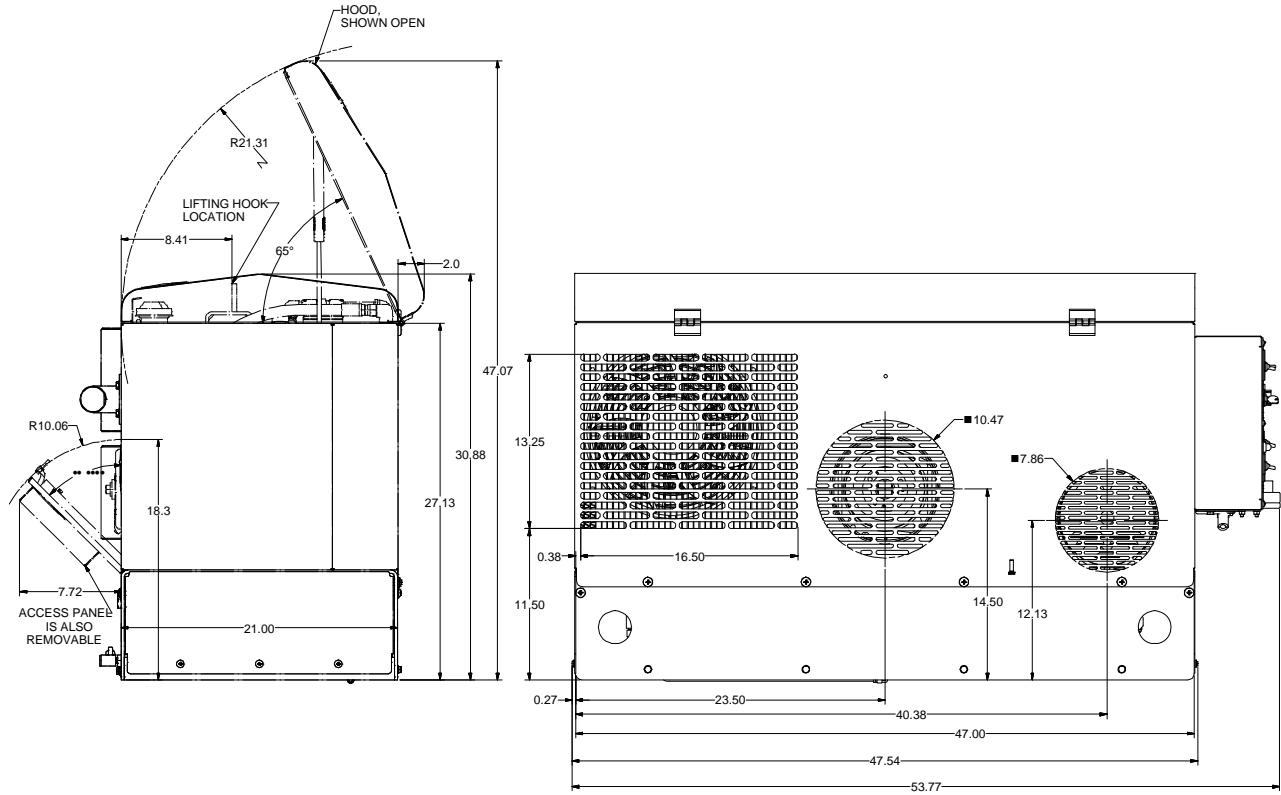

050518\_r2

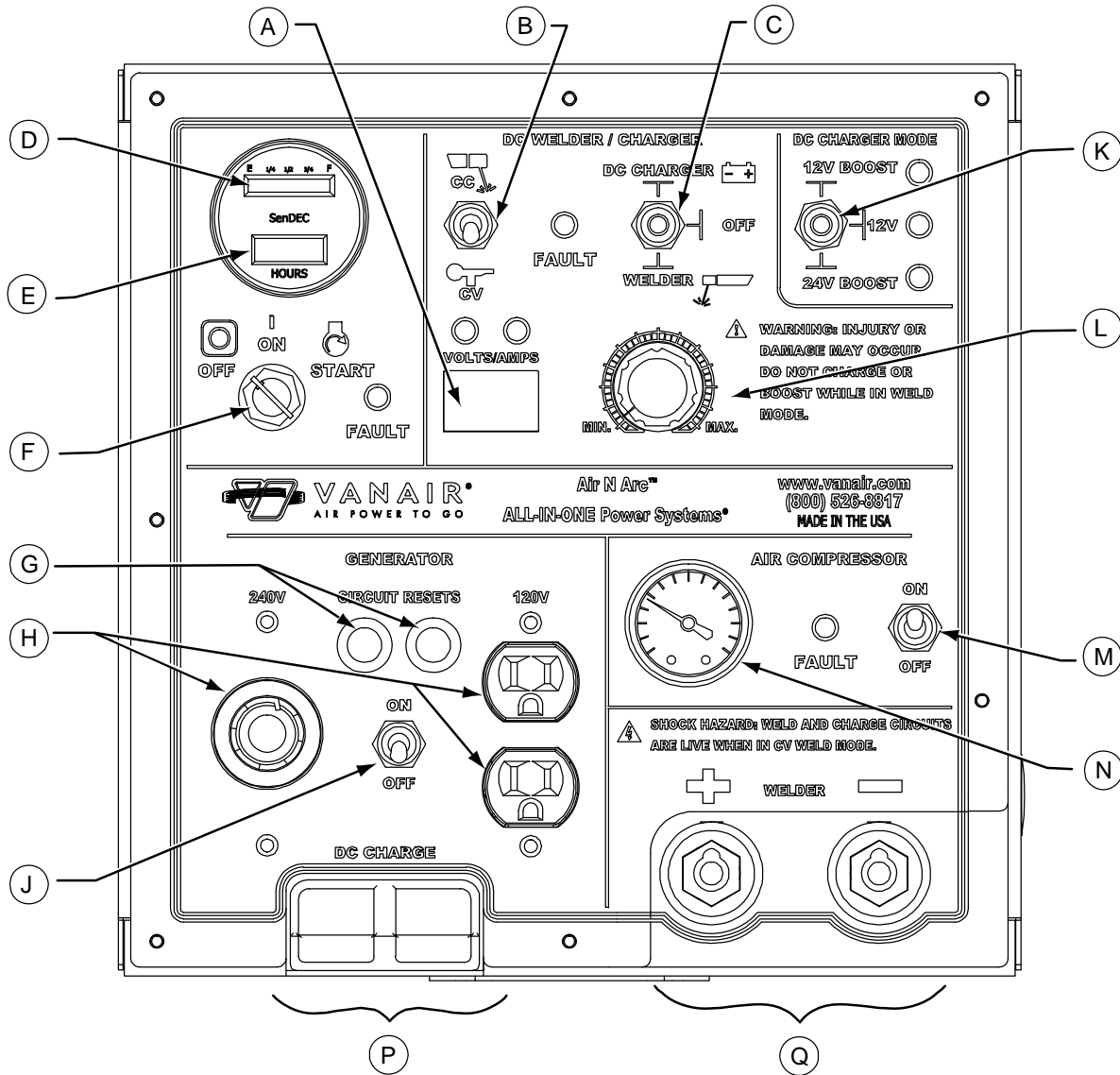

KEY	DESCRIPTION	KEY	DESCRIPTION
A	VOLTS/AMPS METER	J	GENERATOR CONTROL ON/OFF SWITCH
B	WELDER CC/CV TOGGLE SWITCH	K	DC CHARGER 12V / 24V TOGGLE SWITCH
C	DC CHARGER/WELDER TOGGLE SWITCH	L	VOLTS/AMPS MANUAL ADJUSTMENT DIAL
D	FUEL GAUGE	M	COMPRESSOR ON/OFF SWITCH
E	HOUR METER	N	AIR PRESSURE GAUGE
F	ENGINE CONTROL(ON/OFF/START SWITCH)	P	BATTERY CABLE RECEPTACLE
G	CIRCUIT BREAKER TRIP/RESET BUTTONS	Q	WELDER LEAD CONNECTIONS
H	AC VOLTAGE OUTLETS		

Figure 5-1: Instrument Panel Functions

# SECTION 5: OPERATION

## 5.1 GENERAL INFORMATION

The Air N Arc 300 All-In-One Power System has a comprehensive array of controls and indicators for each function of the power system. Understanding the correct operation of the 300 Series system will help you to understand and recognize when the system is operating optimally. The information in the Operation Section will help the operator to recognize and interpret the readings, which will call for service or indicate the beginning of a malfunction.

System Operation Group	Manual Section	Location
Engine Start-up and Shutdown Procedure	5.2	page 46
Engine Start-up	5.2.1	page 47
Engine Shutdown	5.2.2	page 47
Engine Throttle Control Functions	5.3	page 48
Operating the Welder	5.4	page 49
Welder Operating Procedure	5.4.1	page 49
CC (Constant Current) Mode	5.4.1.1	page 49
CV (Constant Voltage) Mode - Using a Voltage Sensing Suitcase Feeder	5.4.1.2	page 50
CV (Constant Voltage) Mode - Using a Spool Gun	5.4.1.3	page 51
Operating the Generator	5.5	page 52
Operating the Air Compressor	5.6	page 53
Operating the Battery/Boost Charger	5.7	page 54
Connection - Disconnection Sequence and Operation	5.7.1	page 55

 **WARNING**

Before starting, performing maintenance, or replacing parts, relieve the entire system pressure by opening the air tank drain/vent valve, which will vent all pressure to the atmosphere.

 **WARNING**

Before performing maintenance or repair operations on the compressor, ensure that all power has been removed and locked out to prevent accidental start-up.

 **WARNING**

Follow all applicable safety recommendations as outlined in *Section 1: Safety* of this manual.

**NOTE**



Before starting the Vanair® Air N Arc 300 All-In-One Power System, read this section thoroughly and familiarize yourself with the controls and indicators - their purpose, location and use.

**NOTE**

If any of the compressor, generator or welder switches are set to ON prior to starting, the machine will start at full speed.

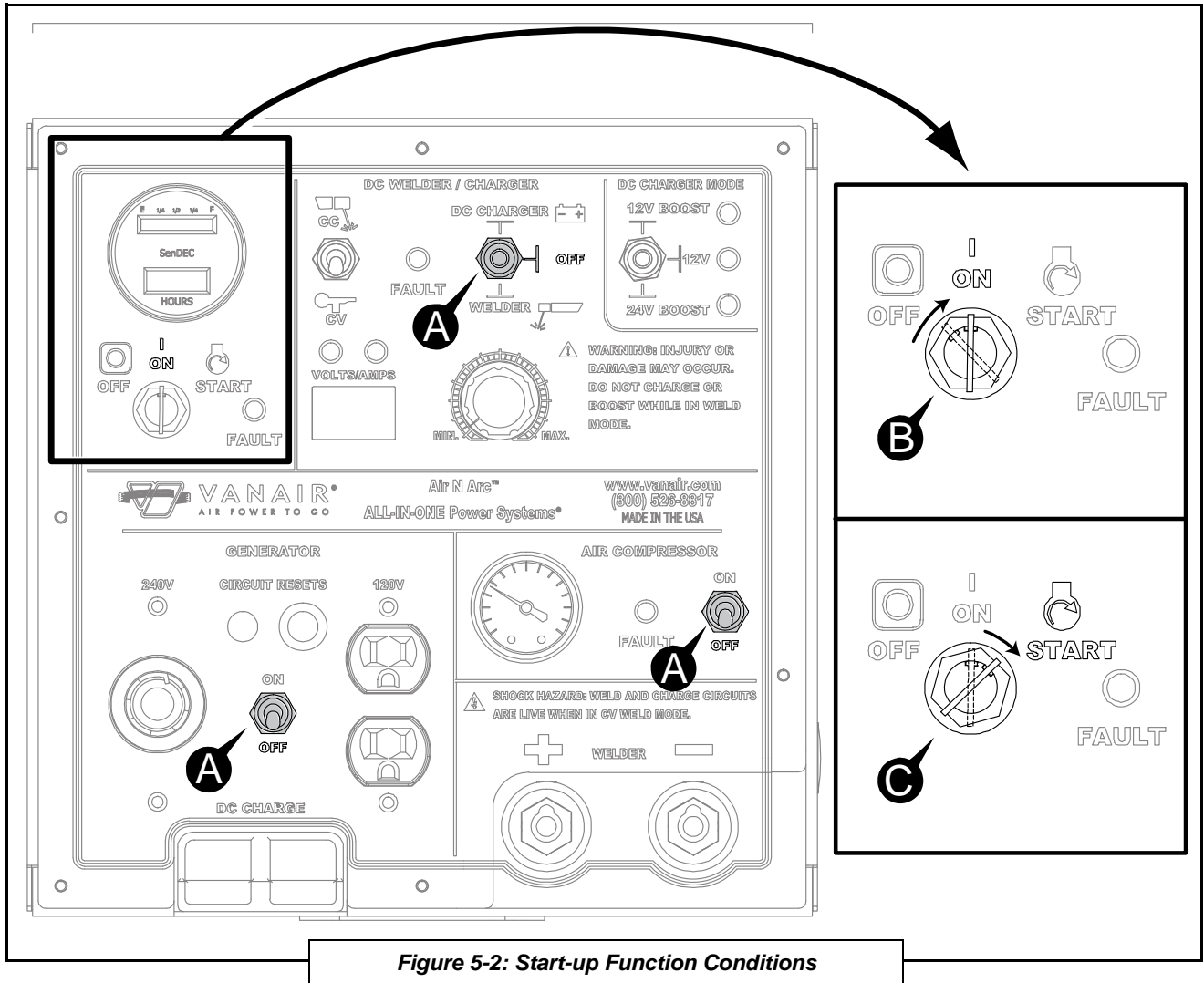

Figure 5-2: Start-up Function Conditions

## 5.2 ENGINE START-UP AND SHUTDOWN PROCEDURE

### NOTE

If start-up and shut-down procedures are not followed, damage to the system and its components may occur.



### WARNING

Machine hood and front access panel must be closed before starting. Interlock switches will not allow starting with panels open. After starting, engine hood may be opened, but opening belt access panel will shut down the engine.

Consult **Figure 5-1: Instrument Panel Functions** for operating procedures detailed in this section. The various operation and control functions of the system via the instrument panel are explained in detail in **Appendix B** of this manual. Consult **Sections B.1, Instrument Panel Key Function Map**, and particularly **Sections B.2.1**



through **B.2.4**, which offer detailed guidance concerning machine start-up and shutdown procedures.

### 5.2.1 ENGINE START-UP

Consult **Figure 5-2**, and the following steps:

1. Check to make sure all switches [**A**] (Welder, Generator, and Compressor) are in the **OFF** position prior to starting.
2. Turn the engine control switch to the **ON** position [**B**]; wait 3-5 seconds for the fuel pump to prime the system.
3. Continue turning control switch to the **START** position [**C**] until the engine starts (when the switch is let go, it will revert back to **ON** position).
4. Let engine run at idle for a 3-5 minutes to allow for warm up sequence.

### 5.2.2 ENGINE SHUTDOWN

Consult **Figure 5-1**. In addition, **Appendix B, Section B.2.1** shows a detailed guidance concerning machine shut down procedure. To shut the engine off at any time, turn the engine control switch to the **OFF** position. However, this method is best reserved for emergency shutdown situations only. Vanair® recommends that the following procedure is used for routine shutdowns in order to keep the system in optimal condition, and minimize undue stress that may occur during the next start up session if some of the machine conditions were left in working mode(s) or had auxiliary power draws left intact (such as a tool receptacle left plugged into the generator, etc.).

To prepare the machine for shutdown:

1. Shut off any tools or other items that are drawing power from the generator, or compressed air from the air tank.
2. Close all service valves.
3. Unplug any power cords that are plugged into the generator panel.
4. Turn the **Compressor, Generator** and **Welder** switches on the control panel to the **OFF** position.
5. Allow machine to run at idle for a 3-5 minutes to allow for a cool down sequence.
6. Turn the **Engine Control Switch** to the **OFF** position. If no air leaks are present, the

#### NOTE

Engine fault light will be on with the key switch turned to the **ON** position before starting the engine.



#### CAUTION

Compressors and engines generate heat and create hot surfaces. Use caution when operating and servicing equipment. Some surfaces and components may be hot.

#### NOTE

Refer to Engine Operator's Manual for additional information pertaining to the starting of the engine.

#### NOTE

Regarding the compressor: once the machine has built up full pressure, it will wait two and a half (2.5) minutes until it idles down; turning off the switch idles it down automatically.

engine should start at idle speed the next time it is started.

### 5.3 ENGINE THROTTLE CONTROL FUNCTIONS

The engine speed is controlled by three factors:

1. The level of air pressure in the tank and the position of the compressor switch.
2. The position of the welder switch on the unit control panel, and the use of the welder.
3. The position of the generator switch on the control panel.

Consult **Table 5A: Engine Throttle Control Function Conditions** to understand how the engine speed relates to the demand(s) of the machine system's output functions.

<b>NOTE</b>
<p>The amps/volts display will read the set value for five (5) seconds when the dial is adjusted, and the actual output value five (5) seconds after the dial has been adjusted.</p>

<b>Pressure Setting</b>	<b>Compressor Switch</b>	<b>Generator Switch</b>	<b>Welder Switch</b>	<b>Engine Speed Condition Result</b>
<b>Tank Pressure Below (&lt;) 100 PSI or Set Pressure<sup>II</sup></b>	ON	OFF	OFF	Engine runs at full throttle (3600 RPM).
<b>Tank Pressure Above (≥) 100 PSI or Set Pressure<sup>II</sup></b>	OFF	OFF	OFF	Engine runs at idle speed (1650 RPM), ready for application.
	ON	OFF	ON	Welder can be activated by striking an arc, and Engine runs at idle speed (1650 RPM), ready for application.
	ON	ON	OFF	Engine runs at full throttle speed (3600 RPM); generator is ready for use <sup>III</sup> .
	ON	ON	ON	Full throttle and all items available for use.
<sup>I</sup> Any combination of the 300 Power System output functions (compressor, generator, welder) used simultaneously at capacity will have an adverse affect on engine running at full throttle.				
<sup>II</sup> Factory set pressure: 100 PSI = ON / 125 PSI = OFF				
<sup>III</sup> Consult <b>Appendix A, Section A.3, Wattage Requirements for Common Receptacle Units</b> for a listing of wattage requirements of various implements.				

## 5.4 OPERATING THE WELDER

 <b>WARNING</b>
<p>Before attempting any welding procedure, the operator must be aware of general safety practices, and particularly those pertaining to welding, as found in Section 1.4 of this manual.</p>

Consult **Figure 5-3**. The **variable power dial** adjusts the welder amperage (30 to 300 amps), or voltage (15 to 40 volts) for the desired weld heat. Turning the power dial clockwise increases the amperage or voltage, and turning the power dial counterclockwise decreases the amperage or voltage. The power dial may be adjusted while welding.

For visual depiction of instrument panel adjustments concerning the DC Welder/Charger Mode functions, consult **Appendix B, Section B.4.1** through **Section B.4.6**.

### 5.4.1 WELDER OPERATING PROCEDURE

#### 5.4.1.1 CC (CONSTANT CURRENT) MODE

CC (Constant Current) Mode is commonly referred to as - Stick Welding, Arc Welding, or Shielded Metal Arc Welding (SMAW)

1. With the engine shut off, insert the twist lock connections of the ground clamp and the electrode holder cables into the welder connection ports on the control panel. For Direct Current Electrode Positive (DCEP) connect the electrode holder to the positive (+) port, and the ground clamp to the negative (-) port. For Direct Current Electrode Negative (DCEN) connect the electrode holder to the negative (-) port, and the ground clamp to the positive (+) port.
2. Select the appropriate electrode for the material and process being performed. See **Table 5B** for selecting an electrode.
3. Place the ground clamp on the work piece and insert the appropriate welding rod into the electrode clamp.
4. Start the engine (**See Section 5.2, Engine Start-up and Shutdown Procedure**).

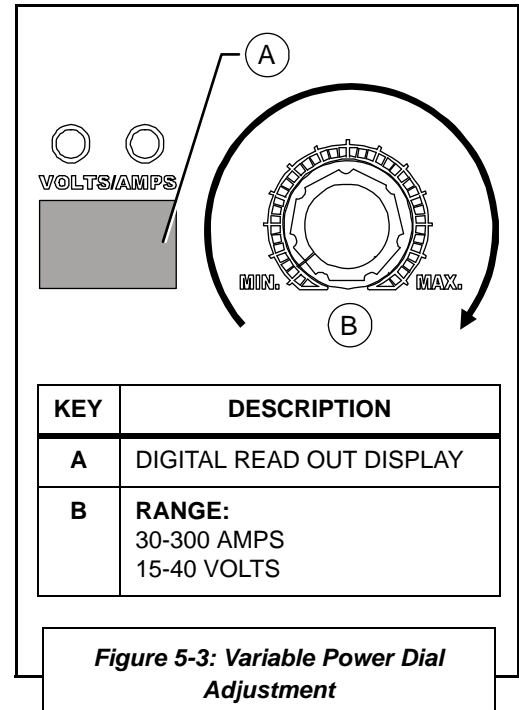

<b>NOTE</b>
<p>If a longer welding lead is desired, optional 50 ft. lead segments may be purchased from Vanair Manufacturing, Inc. for a maximum lead length of 100 ft.</p>

 <b>WARNING</b>
<p>Do not rely on the thermal overload circuit breakers on the generator to protect personnel, power tools, or the generator. The thermal overload circuit breakers on the generator require time to overheat when the generator is operating in an overload condition — they do not provide instant protection against short circuiting or overload conditions. Always use GFCI protected extension cords and power strips when using the generator.</p>

<b>METAL THICKNESS</b>	<b>ELECTRODE SIZE</b>	<b>WELDING AMPERES</b>
1/16-1/8	3/32	50-90
1/8-1/4	1/8	90-140
¼-3/8	5/32	120-180
3/8-1/2	3/16	150-230

5. On the control panel, place the CC/CV switch in CC mode. Place the DC Charger/Welder switch in welder mode.
6. Adjust the power dial to the appropriate amperage setting for the material and the electrode being used. (See **Table 5B** for electrode amperage ratings). At anytime during welding, the power dial may be adjusted to the desired amperage level.
7. When you strike the electrode against the material being welded, the engine will go to high idle and deliver the selected amperage through the electrode. Now you may begin to weld.
8. After a weld has been completed, and there is no contact between the electrode and the metal for 30 seconds, the engine will return to idle.

#### **5.4.1.2 CV (CONSTANT VOLTAGE) MODE - USING A VOLTAGE SENSING SUITCASE FEEDER**

CV (Constant Voltage) Mode – commonly referred to as - Wire Welding, MIG welding, or Gas Metal Arc Welding (GMAW)

1. With the engine shut off, insert the twist lock connection of the ground clamp into the negative (-) welder connection port on the control panel. Insert the power lead segment from the suitcase feeder into the positive (+) welder connection port on the control panel.
2. Place the ground clamp from the suitcase feeder and the ground clamp from the Air N Arc 300 on the work piece.
3. Start the engine (**See Section 5.2, Engine Start-up and Shutdown Procedure**).

4. On the control panel, place the DC Charger/ Welder switch in welder mode. Place the CC/CV switch in CV mode.
5. Adjust the power dial on the Air N Arc 300 to the appropriate voltage setting for the material being welded. Adjust the power dial on the suitcase feeder for the material being welded. At anytime during welding, the power dial may be adjusted to the desired voltage level.

#### 5.4.1.3 CV (CONSTANT VOLTAGE) MODE - USING A SPOOL GUN

CV (Constant Voltage) Mode – commonly referred to as - Wire Welding, MIG welding, or Gas Metal Arc Welding (GMAW)

#### NOTE

**When using a spool gun, an adapter with contactor must be used. Please consult the spool gun manufacturer for appropriate adapter.**

1. With the engine shut off, insert the twist lock connection of the ground clamp into the negative (-) welder connection port on the control panel. Insert the power lead segment from spool gun adapter into the positive (+) welder connection port on the control panel.
2. Place the ground clamp from the Air N Arc 300 on the work piece.
3. Start the engine (**See Section 5.2, Engine Start-up and Shutdown Procedure**).
4. On the control panel, place the DC Charger/ Welder switch in welder mode. Place the CC/CV switch in CV mode.
5. Adjust the power dial on the Air N Arc 300 to the appropriate voltage setting for the material being welded. At anytime during welding, the power dial may be adjusted to the desired voltage level.

What the numbers mean that are used to identify a stick welding electrode:

Using E6010 for an example...

TABLE 5C: WELDING ROD TYPE, POLARITY AND FLUX CODES		
DIGIT	TYPE OF COATING	WELDING CURRENT
10	High cellulose sodium	DC+
11	High cellulose potassium	AC or DC+ or DC-
12	High titania sodium	AC or DC-
13	High titania potassium	AC or DC+
14	Iron powder titania	AC or DC- or DC+
15	Low hydrogen sodium	DC+
16	Low hydrogen potassium	AC or DC+
27	Iron powder iron oxide	AC or DC+ or DC-
18	Iron powder low hydrogen	AC or DC+
20	High iron oxide	AC or DC+ or DC-
22	High iron oxide	AC or DC-
24	Iron powder titania	AC or DC- or DC+
28	Low hydrogen potassium iron powder	AC or DC+

The E indicates Electrode because some welding rods are not electrodes. The 60 in 6010 indicates the tensile strength in psi. 60,000 lbs.

The last 2 digits indicate position and polarity along with what type flux. See **Table 5C**.

## 5.5 OPERATING THE GENERATOR

### NOTE

The Power System is designed to support a multi-function project. However, if the generator is operating at a high percentage of its rated capacity, and the welder and air compressor are also being used, the resulting drop in engine speed may produce a low voltage condition that will damage the generator and power tools being used.

For a detailed account concerning the Generator Mode ON and OFF functions, consult **Appendix B, Section B.5.1** and **Section B.5.2**.

To operate the generator:

1. Start the engine.

- Turn the Generator switch on the control panel to the **ON** position.

<b>NOTE</b>
<b>Only plug power cords into the generator receptacles <i>AFTER</i> the engine is running at full speed.</b>

<b>NOTE</b>
<b>Be careful not to overload the rated capacity of the generator - 6,800 watts (28 amps @ 240V) continuous.</b>

Combined output on all generator receptacles is limited to the total rated generator capacity. For example; if 1,500 watts (12.5 amps) is being drawn on the 120V duplex receptacle, only 3,700 watts (15.5 amps) is available at the 240V receptacle. Reference **Appendix A, Section A.3, Wattage Requirements for Common Receptacle Units**, for general information on the power requirements of common power tools, motors and extension cords. If the equipment is not listed in **Section A.3**, check the desired power tool, motor or extension cord manufacturer’s specifications.

If the thermal overload circuit breakers on the generator are tripped due to an overload condition, press the white reset buttons on the generator panel to reset the breakers (**Figure 5-4**).

 <b>WARNING</b>
<b>If one of the generator circuit breakers is tripped, the cause of the overload must be determined before the circuit breaker is reset and work is resumed.</b>

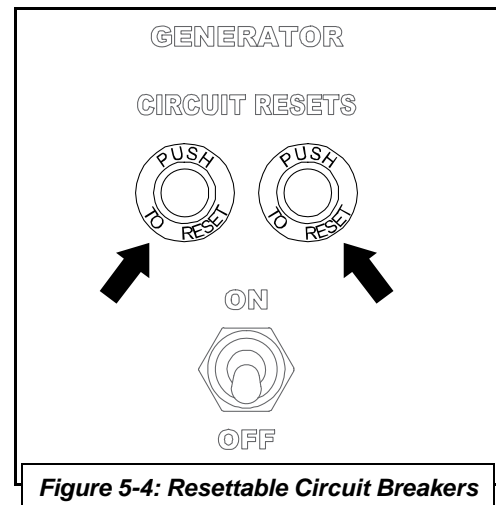

## 5.6 OPERATING THE AIR COMPRESSOR

The air compressor and the supply of high pressure air can be turned off. Whenever the pressure in the air tank drops below 150 psi or the set pressure, the engine will run at high speed until the pressure in the tank reaches 175 psi or set pressure. the pressure gauge on the panel displays the current tank pressure.

<b>NOTE</b>
<b>The Air N Arc 300 Power System unit features a high pressure, 175 psi air system. Check the maximum air pressure rating on the air tools being used. The operator is responsible for regulating the air pressure when necessary (See Section 6.5.15, Adjusting the Pressure Setting).</b>

**NOTE**

The pressurized air system requires routine maintenance. See Section 6.3, Maintenance Schedule Table, to learn about important maintenance procedures.

For a detailed account concerning the Compressor Mode ON and OFF functions, consult **Appendix B, Section B.3.1** and **Section B.3.2**.



**CAUTION**

Exposed high pressure air lines on the unit become hot during operation—keep everyone clear.



**WARNING**

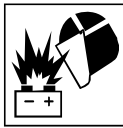

Always wear a face shield when connecting or disconnecting battery charging cables, and always follow the connection and disconnection sequence. Electrical sparks can cause a battery to explode, resulting in serious injury.

When purchasing air tools or planning a project, the rated capacity of the compressor (40 CFM @ 175 psi) will need to be taken into consideration. See **Appendix A, Section A.4, Air Tool Air Consumption Chart**, for information on the compressed air requirements of common tools. If the equipment is not listed in **Section A.4**, check the desired power tool manufacturer's specifications.

**5.7 OPERATING THE BATTERY BOOSTER/CHARGER**

The Vanair state-of-the-art battery charging module and the optional battery charging cables add further versatility to the 300 Series Power System. The battery charging system operates off the welding generator, and not the main AC power generator.

**IMPORTANT**

To prevent damaging voltage spikes, the battery cables must be disconnected from the battery to be charged in any vehicle equipped with a computer, or any equipment with sensitive electronic components. Failure to follow this warning can result in damage or failure of any or all electronic components, thus voiding the warranty of the machine.

Consult **Table 5B** for factory preset ranges. The module has been factory-adjusted for 12 VDC charging, and a maximum current output of 300 amps.



**WARNING**

DO NOT charge or boost while in Weld Mode. Personal injury or damage may occur.

**NOTE**

Never leave the machine unattended while charging a battery. Always carefully monitor the charging system while it is in use; the high amperage level that the unit produces can damage the battery being charged, or the other components, if the unit is left connected for an extended period of time.

**TABLE 5B: FACTORY PRESETS**

	FACTORY ADJUSTMENT RANGE	STANDARD PRE-SET
12V CHARGER	12V - 15V	14V
12 V BOOST	14V - 17V	16V
24V CHARGER/ BOOST	26V - 35V	30V

The module output has been set at 14 VDC for the 12V charge option, 16 VDC for 12V boost, and 30 VDC for the 24V option. This output has been pre-set by the factory



and can only be adjusted by authorized factory personnel.

During charging, if the machine begins to cycle between high and low idle, then the battery is fully charged.

### 5.7.1 CONNECTION - DISCONNECTION SEQUENCE AND OPERATION

#### IMPORTANT

**Never attach boost cables to the panel before attaching to the battery. Always attach cables to the battery first.**

1. With the engine off, insure that the welder, DC charger switch, and any other engine control switch is in the **OFF** position.
2. Attach the clamps of the battery charge cable to the battery to be charged. RED to the positive terminal, BLACK to the negative terminal (*Figure 5-5*).
3. Plug the battery charge cables into the battery cable connection.
4. Start the engine and wait for all indicator lights to turn off. Place the DC Welder/Charger selector toggle switch in the **DC Charger** position, and then the DC Charger Mode switch to the correct position. The engine should come up to operating speed; the battery is being charged.
5. When machine begins to cycle between high and low idle then the battery is fully charged.
6. To disconnect the charging system, place the DC Welder/Charger selector toggle switch to the **OFF** position.
7. Allow engine to idle down, then shut down the engine.
8. Now it is safe to disconnect the clamps from the battery being charged, and the battery cable connection on the front of the machine.

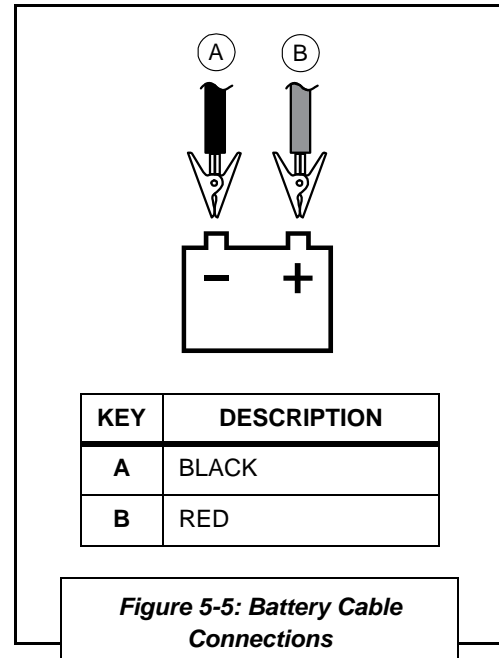

**BLANK PAGE**

# SECTION 6: MAINTENANCE

## 6.1 GENERAL INFORMATION

A strict maintenance program is the key to long life for the Air N Arc 300 Series All-In-One Power System package. Below is a program that, when adhered to, should keep the package in top operating condition. Refer to **Section 6.5, Parts Replacement and Adjustment Procedures** in this section of the manual for detailed descriptions of specific compressor system components. The following table lists the main topics in order of appearance for this section:

System Component or Component Group	Manual Section	Location
Routine Maintenance Schedule	6.2	page 57
Maintenance Schedule Table	6.3	page 59
Replacement Parts	6.4	page 63
Parts Replacement and Adjustment Procedures	6.5	page 63
Servicing the System Fuses and Circuit Breakers	6.6	page 94
Extreme Condition Operation	6.7	page 95
Storage and Intermittent Use	6.8	page 98

## 6.2 ROUTINE MAINTENANCE SCHEDULE

Vanair® Manufacturing, Inc. considers the maintenance schedule given in **Section 6.3, Maintenance Schedule Table**, to be part of the warranty agreement with the customer. This maintenance regimen must be followed in order to protect the warranty of the machine package.

Vanair Manufacturing, Inc. especially requires that a consistent service regimen be established for engine oil changes, and engine and compressor air filter servicing. The following schedule is designed so that many of the other maintenance tasks are completed when the engine



### WARNING

**DO NOT** remove caps, plugs and/or other components when compressor is running or pressurized. Stop compressor and de-pressurize system prior to maintenance of system.

Wear personal protective equipment such as gloves, work boots, and eye and hearing protection as required for the task at hand.



### WARNING

Follow all applicable safety recommendations as outlined in **Section 1: Safety** of this manual.

### NOTE

Operating the machine package in a severe environment may require more frequent service intervals.

**NOTE**

**Follow the prescribed periodic maintenance (PM) schedule as recommended. Perform the required PM schedule at recommended intervals. Failure to follow this prescribed periodic maintenance at the recommended intervals will impair the package safety, performance characteristics, shorten the package's life, and will negatively affect the warranty coverage of the package.**

and compressor air filters are serviced, and the engine oil is changed.

Please take a moment to acquaint yourself with the following service schedule. There is also a corresponding service log (**Appendix C, Maintenance & Service Log**) to assist the customer in establishing a maintenance routine log.

For assistance in obtaining routine maintenance or replacement parts, consult **Section 9.1, Parts Ordering Procedure**, and **Table 9A: Recommended Spare Parts List**.

6.3 MAINTENANCE SCHEDULE TABLE

		INTERVALS				NOTE
BREAK-IN PERIOD	MAINTENANCE SCHEDULE	After 8 Hours or Daily	Every 100 Hours or One Year	Every 200 Hours	After 600 Hours	
Hours of First 20 Operation	Hourly or Calendar Period - whichever comes first					If working in dusty or dirty conditions, reduce the recommended time intervals between servicing by half for engine and compressor oil change, and engine and compressor filter servicing.
KEY	TASK DESCRIPTION					ACTION TO TAKE
1	Check tension of micro-v belt that drives the air compressor	●	●	●	●	Tighten belt if necessary. Consult <b>Section 6.5.16.1</b> .
2	Change engine oil and engine filter	●	●	●		Consult the oil change procedure in the Engine Operator's Manual to change the engine oil and engine oil filter.
3	Wash engine air pre-cleaner	●	●	●	●	Remove and wash engine air filter pre-cleaner: Consult the Engine Operator's Manual for procedure
4	Check engine oil level	●	●	●	●	Consult engine oil level check procedure, <b>Section 6.5.13</b> .
5	Check air tank for water accumulation	●	●	●	●	Drain any water from the air tank, per procedure in <b>Section 6.5.9</b> .
6	Check air compressor oil level	●	●	●	●	Check resting oil level via the dipstick; follow compressor fill procedure ( <b>Section 6.5.4</b> ) if low.
7	Inspect unit for oil leaks or damage	●	●	●	●	Visually note any leaks or evidence of leaks around the compressor unit and hose connections. Tighten any loose connection point where needed. Repair or replace any damaged part.
8	Inspect cooler fins (both engine and compressor oil coolers) for contamination)	●	●	●	●	Clean or clear as necessary. Refer to <b>Section 6.5.12</b> .
9	Inspect ventilation openings	●	●	●	●	Ensure openings are not blocked or clogged with debris. Clean or clear as necessary.

6.3 MAINTENANCE SCHEDULE TABLE

		INTERVALS				NOTE
BREAK-IN PERIOD	MAINTENANCE SCHEDULE	After 8 Hours or Daily	Every 100 Hours or One Year	Every 200 Hours	After 600 Hours	
First 20 Hours of Operation	Hourly or Calendar Period - whichever comes first					if working in dusty or dirty conditions, reduce the recommended time intervals between servicing by half for engine and compressor oil change, and engine and compressor filter servicing.
KEY	TASK DESCRIPTION	ACTION TO TAKE				
10	Clean and inspect engine air filter	●	●	●	●	Consult the air filter procedure in the Engine Operator's Manual to change the engine air filter.
11	Clean and inspect compressor air filter	●	●	●	●	Consult the air compressor air filter maintenance procedure (Sections 6.5.1.1 through 6.5.1.3).
12	Manually test pressure relief valve on air tank for proper operation	●	●	●	●	Consult the air tank's pressure relief valve check procedure (Section 6.5.10).
13	Change air compressor oil, oil filter and coalescer element		●		●	Consult the following sections for procedures on how to change compressor oil, oil filter and separator element: Compressor Oil: Sections 6.5.3 and 6.5.5 Compressor Oil Filter: Section 6.5.4 Coalescer Element: Section 6.5.6
14	Check tension of air compressor drive belt and tighten if necessary		●		●	Consult Sections 6.5.16.1 and 6.5.16.2 for procedures on how to check and re-tension the air compressor drive belt.
15	Inspect air compressor drive belt and serpentine welder drive belt for wear, damage or excessive cracking			●	●	Ensure that drive belts are in satisfactory operating condition, and are tensioned adequately. Should a belt need to be re-tensioned or replaced, consult Section 6.5.16 through Section 6.5.16.4.
16	Check battery cables and connections			●	●	Clean and tighten as necessary. Replace any worn cables.
17	Inspect unit mounting bolts			●	●	Tighten any loose mounting bolts as necessary.

6.3 MAINTENANCE SCHEDULE TABLE

KEY	TASK DESCRIPTION	INTERVALS				ACTION TO TAKE	
		BREAK-IN PERIOD	MAINTENANCE SCHEDULE	Hourly or Calendar Period - whichever comes first			
		First 20 Hours of Operation	After 8 Hours or Daily	Every 100 Hours or One Year	Every 200 Hours	After 600 Hours	NOTE
18	Blow out the DC welding generator and AC generator				●	●	If working in dusty or dirty conditions, reduce the recommended time intervals between servicing by half for engine and compressor oil change, and engine and compressor filter servicing.
20	Replace engine fuel filters				●	●	
21	Check compressor cut-in and cut-out pressures					●	
22	Replace engine spark plugs (Check at 200 hours)					●	
23	Replace engine air filter			●	●	●	
24	Check the engine speed					●	
25	Inspect the welding leads and battery charging cables					●	
26	Inspect welding electrode clamp and ground clamp					●	
27	Replace the air compressor and generator drive belts					●	
28	Inspect the generators and the automatic belt tensioner					●	

6.3 MAINTENANCE SCHEDULE TABLE

INTERVALS		ACTION TO TAKE				
BREAK-IN PERIOD	MAINTENANCE SCHEDULE Hourly or Calendar Period - whichever comes first					
First 20 Hours of Operation	<table border="1"> <tr> <td>After 8 Hours or Daily</td> <td>Every 100 Hours or One Year</td> <td>Every 200 Hours</td> <td>After 600 Hours</td> </tr> </table>	After 8 Hours or Daily	Every 100 Hours or One Year	Every 200 Hours	After 600 Hours	<p>If working in dusty or dirty conditions, reduce the recommended time intervals between servicing by half for engine and compressor oil change, and engine and compressor filter servicing.</p>
After 8 Hours or Daily	Every 100 Hours or One Year	Every 200 Hours	After 600 Hours			
TASK DESCRIPTION						
*Consult <b>Section 9.1</b> and <b>Table 9A</b> for replacement part order numbers.						
KEY						



## 6.4 REPLACEMENT PARTS

Replacement parts should be purchased through your local Vanair representative or where the 300 Series Power System was purchased. If, for any reason, parts are not available in this manner, they can be purchased through Vanair directly.

NOTE
For assistance when ordering new replacement parts, consult <i>Section 9.1, Parts Ordering Procedure</i> , and <i>Table 9A: Recommended Spare Parts List</i> .

### VANAIR MANUFACTURING, INC.

10896 West 300 N.  
 Michigan City, IN 46360  
 Telephone: (800) 526-8817  
 (219) 879-5100  
 Service Fax: (219) 879-5335  
 Parts Fax: (219) 879-5340  
 Sales Fax: (219) 879-5800

www.vanair.com

NOTE
If additional spare parts are being stored for future use, make certain that they are stored in proper containers that allow for protection against contamination, and kept in a clean area of moderate temperature reading. For information on storing the machine package for periods of non-use, consult <i>Section 6.8.2, Long Term Storage</i> .

## 6.5 PARTS REPLACEMENT AND ADJUSTMENT PROCEDURES

System Component or Part Group Task	Manual Section	Location
Parts Replacement and Adjustment Procedures	6.5	page 63
Continued on next page		

 <b>WARNING</b>
Relieve pressure from the compressor system before removing any components. The compressor and engine oil levels should be checked with the unit shut down and the oil allowed to properly settle.

 **CAUTION**

Always wear personal protective equipment such as gloves, safety shoes or boots, eye, and hearing protection as required for the task at hand.

 **CAUTION**

Compressors and engines generate heat and create hot surfaces. Use caution when operating or servicing equipment. Some surfaces and components may be hot.

**NOTE**

It may be necessary to change the compressor oil and oil filter at earlier intervals if the compressor oil has water contamination or if the compressor system is operated in a dirty environment.

**NOTE**

Do not mix different compressor fluid types. Use Vanguard compressor oil.

**NOTE**

Refer to the Engine Operator’s Manual for detailed maintenance and replacement procedures for the engine.

**NOTE**

Inspect and replace damaged components before operation with Genuine Vanair Replacement Parts. Using replacement parts other than Genuine Vanair Replacement Parts will void the warranty.

System Component or Part Group Task	Manual Section	Location
Compressor Air Filter	6.5.1	page 65
Compressor Air Filter Check	6.5.1.1	page 65
Compressor Air Filter Inspection	6.5.1.2	page 66
Compressor Air Filter Replacement	6.5.1.3	page 66
Repairing the Air Inlet Valve	6.5.2	page 67
Checking the Compressor Oil	6.5.3	page 69
Replacing the Compressor Oil Filter Element	6.5.4	page 70
Changing the Compressor Oil	6.5.5	page 72
Replacing the Air/Oil Spin-on Coalescer	6.5.6	page 73
Repairing the Compressor Shaft Seal	6.5.7	page 74
Part I - Removing the Compressor Serpentine Belt	6.5.7.1	page 74
Part II - Accessing the Compressor Unit Shaft Seal	6.5.7.2	page 76
Part III - Replacing the Compressor Serpentine Belt	6.5.7.3	page 77
Replacing the Air Inlet Solenoid Valve	6.5.8	page 78
Solenoid Valve—Preparation Before Mounting	6.5.8.1	page 78
Connecting the New Solenoid Valve	6.5.8.2	page 80
Draining the Air Tank	6.5.9	page 81
Checking the Air Tank Relief Valve	6.5.10	page 82
Rebuilding the Minimum Pressure/Check Valve	6.5.11	page 82
Setting the Minimum Pressure Valve	6.5.11.1	page 84
Inspecting the System Coolers	6.5.12	page 84
Checking the Engine Oil	6.5.13	page 84
Adjusting The Engine Speed	6.5.14	page 86
Adjusting The Pressure Setting	6.5.15	page 86
<b>Continued on next page</b>		

System Component or Part Group Task	Manual Section	Location
Replacing and Re-tensioning the Serpentine Drive Belts	6.5.16	page 88
Re-tensioning the Air Compressor Serpentine Drive Belt	6.5.16.1	page 88
Replacing the Air Compressor Serpentine Drive Belt	6.5.16.2	page 90
Re-tensioning the Generator Serpentine Drive Belt	6.5.16.3	page 92
Replacing the Generator Serpentine Drive Belt	6.5.16.4	page 92

 <b>WARNING</b>
<b>Relieve pressure from the compressor system before removing any components.</b>

### 6.5.1 COMPRESSOR AIR FILTER

The compressor oil is the key to a long useful life of the air compressor system. Dirt and other foreign matter can be introduced into the compressor system through the air intake. A clean air filter will ensure that the compressor is protected. Consult **Section 6.3, Maintenance Schedule Table** for routine compressor air filter inspection intervals.

#### 6.5.1.1 COMPRESSOR AIR FILTER CHECK

Consult **Figure 6-1** and the following procedure to check the compressor air filter.

TOOLS/ITEMS NEEDED
Not Applicable

REPLACEMENT PART(S)
Not Applicable

1. With the machine off and the ignition key removed, open the hood panel.
2. Remove the three (3) wing nuts [A] from the air filter/inlet valve cover [C] on the top of the compressor unit.
3. Remove air filter element [B] from air filter housing [D].
4. Inspect the air filter element for visible dirt, debris, or damage. **NOTE:** to perform a more thorough inspection of the compressor air filter element, refer to **Section 6.5.1.2**.

If element is in adequate shape to continue using:

5. Re-seat the filter element [B] into filter/inlet valve housing [D].

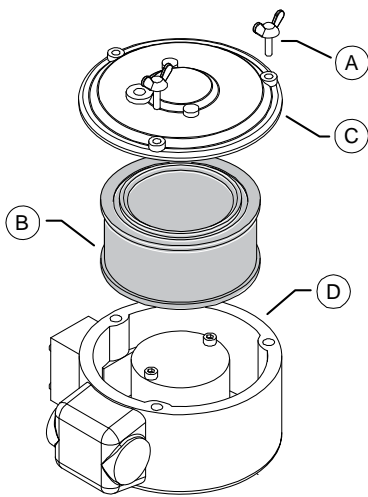

KEY	DESCRIPTION
A	WING NUT (x3)
B	AIR FILTER ELEMENT
C	AIR FILTER HOUSING COVER
D	AIR FILTER HOUSING

**Figure 6-1: Compressor Air Filter**

<b>NOTE</b>
<b>If element is compromised by holes or tears, or the gaskets are worn, or it is in unsatisfactory condition, then it will need to be replaced.</b>

 <b>WARNING</b>
Relieve pressure from the compressor system before removing any components.

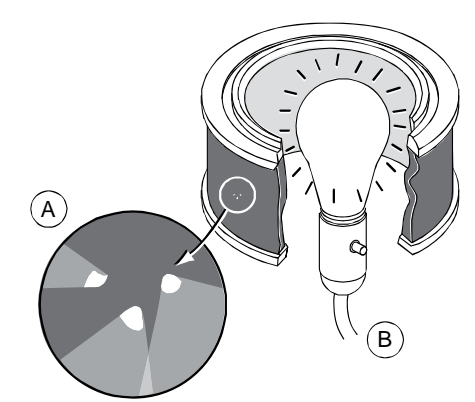

KEY	DESCRIPTION
A	LIGHT SHINING THROUGH PIN-HOLES INDICATES A WORN FILTER ELEMENT
B	TYPICAL LIGHT SOURCE PLACED WITHIN FILTER TO SHINE OUTWARD

**Figure 6-2: Air Filter Inspection**

6. Replace cover [C] and wing nuts [A].
7. Close hood.

### 6.5.1.2 COMPRESSOR AIR FILTER INSPECTION

Consult **Figure 6-2** and the following procedure to inspect the compressor air filter.

TOOLS/ITEMS NEEDED
Light source

REPLACEMENT PART(S)
Not Applicable

1. Place a bright light source inside of the filter element and carefully inspect the filter from the outside in a dark environment to detect any pinholes or tears that may have developed.
2. Inspect the gaskets on the top and bottom of the air filter for any damage or wear.
3. Replace the element if it shows any damage or wear even if the inspection occurs before the recommended replacement interval. Consult **Section 6.5.1.3** if filter needs to be replaced.

### 6.5.1.3 COMPRESSOR AIR FILTER REPLACEMENT

The air filter element uses a pleated paper-type filter to carefully remove accumulated dirt before being compression can begin. **DO NOT** clean the compressor air filter element.

TOOLS/ITEMS NEEDED
Container large enough to accommodate filter

REPLACEMENT PART(S)
Air Filter Element No. 264154-095

To replace worn or damaged air filter with new filter, consult **Figure 6-1**, and the following procedure:

1. With the machine off and the ignition key removed, open the hood panel and locate the compressor air filter.
2. Remove three (3) wing nuts [A] from the air filter/inlet valve cover [C] on the top of the compressor unit.
3. Remove old air filter element [B] from air filter housing [D].

4. Seat a new filter element [B] into filter/inlet valve housing [D].
5. Replace cover [C] and wing nuts [A].
6. Close the hood.
7. Dispose of discarded filter within the guidelines of all applicable local, regional and/or federal laws.

### 6.5.2 REPAIRING THE AIR INLET VALVE

Should a condition occur that requires air inlet valve maintenance (see **Section 7.2, Troubleshooting Guide**), a repair kit is available. To repair the air inlet valve, order air inlet rebuild kit no. 264154-101. Refer to **Figure 6-3**, and the following procedure:

TOOLS/ITEMS NEEDED	REPLACEMENT PART(S)
Hex Head Screwdriver or Wrench	Air Inlet Filter Rebuild Kit No. 264154-101
Adjustable Wrench	

1. Shut down machine and lock out all power, as per the Safety Section of the manual.
2. Locate the compressor's air filter compartment housing and remove the three (3) wing screws [A] from cover [C].
3. Remove air filter [B], and put it aside temporarily so it will not get damaged or soiled; the full air filter inlet valve [D] is now accessible.
4. Remove the two (2) cylinder head screws [E].
5. Grasp the valve [D] and pull upwards to disengage the valve from its valve seating.
6. Disassemble the valve and replace used parts with new parts found in the kit. Refer to **Figure 6-3** to assure correct replacement and part position.

NOTE
Use all of the parts provided in the kit regardless of the old part condition.

7. Once the valve's parts have been replaced with the kit parts and re-assembled, place the rebuilt, complete inlet valve assembly back into position on the valve seating within the air filter housing.

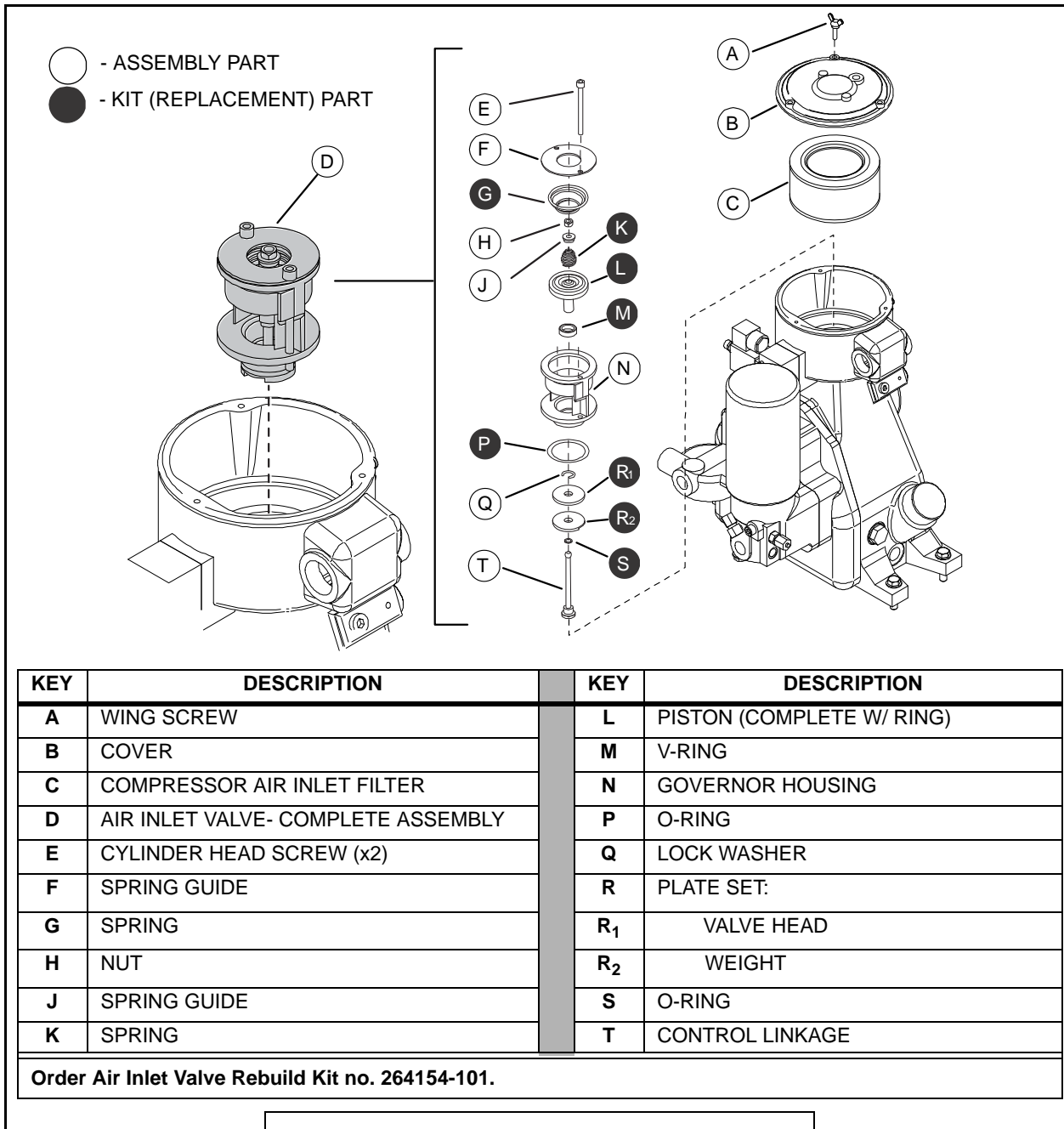

**Figure 6-3: Air Inlet Filter Rebuild Kit**

8. Replace the two (2) cylinder head screws [E] and tighten securely.
9. Replace the air filter [C], or exchange it for a new one if air filter is soiled (refer to **Section 6.5.1, Compressor Air Filter** for air filter inspection check, etc.).
10. Replace the cover [B].

11. Replace the three (3) wing screws [A], and secure tightly.

### 6.5.3 CHECKING THE COMPRESSOR OIL

Having the proper amount of oil in the compressor system is essential to prolonging the equipment's useful life. Checking the compressor oil is the most important service to perform on the 300 Series All-In-One Power System package. Consult **Section 6.3, Maintenance Schedule Table** for routine compressor oil inspection intervals.

 <b>DANGER</b>
<p><b>NEVER</b> check the compressor oil level with the compressor running. Hot oil is under pressure and will spray, causing severe burns.</p> <p>When checking compressor oil level, blow down the pressure to zero, and allow system oil level to settle before removing the fill cap/dipstick.</p>

 <b>WARNING</b>
<p>Relieve pressure from the compressor system before removing any components.</p>

<b>NOTE</b>
<p>The cooler has an aluminum core and if internal cleaning is required, it should be done at a qualified radiator shop. If the lubrication system is properly maintained (changing the oil and filters at the recommended intervals) an internal cleaning should not be necessary during the compressor's service life.</p>

Consult **Figure 6-4** and the following procedure to check the compressor oil.

<b>NOTE</b>
<p>This procedure should only be performed when the compressor is warm immediately after extended operation.</p>

TOOLS/ITEMS NEEDED
Strap Wrench
Adjustable Wrench

REPLACEMENT PART(S)
Vanguard™ Premium Synthetic Oil No. 264626-1/2GAL

1. With the machine off and the ignition key removed, open the hood panel.
2. Locate the fill port end of the compressor oil fill tube [A], and unscrew and remove the compressor oil fill cap/dipstick [B].
3. Wipe off dipstick and insert it back into port.
4. Remove stick and inspect the oil mark.
5. Verify that the oil level is within the range indicated by wet level mark on dipstick [D], as per **Figure 6-4**.

<b>NOTE</b>
<p>Using a brake cleaner to wipe down the dipstick before determining oil level will give a clear indication of oil level on the stick.</p>

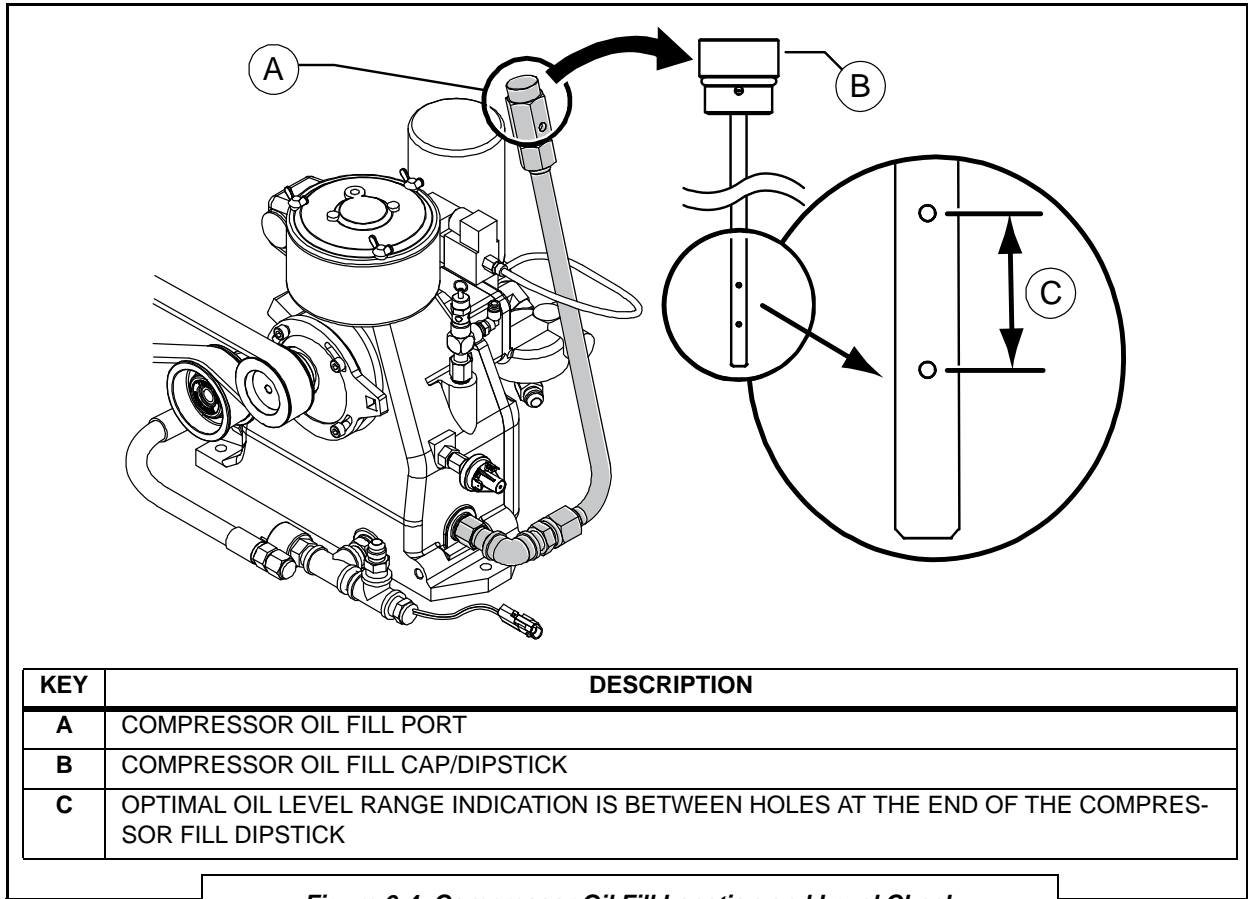

Figure 6-4: Compressor Oil Fill Location and Level Check

6. Add oil as needed, but **DO NOT** overfill.
7. Replace oil fill cap/dipstick [B] and tighten.

### 6.5.4 REPLACING THE COMPRESSOR OIL FILTER ELEMENT

The compressor oil filter element is a spin-on disposable type. Consult **Figure 6-5**, and the following procedure to change the compressor oil filter element. Consult **Section 6.3, Maintenance Schedule Table** for routine compressor oil element change intervals.

TOOLS/ITEMS NEEDED
Strap Wrench
Compressor Oil (enough to coat seal ring, and possibly for a top-off to the proper level)

REPLACEMENT PART(S)
Oil Filter Element No. 266801



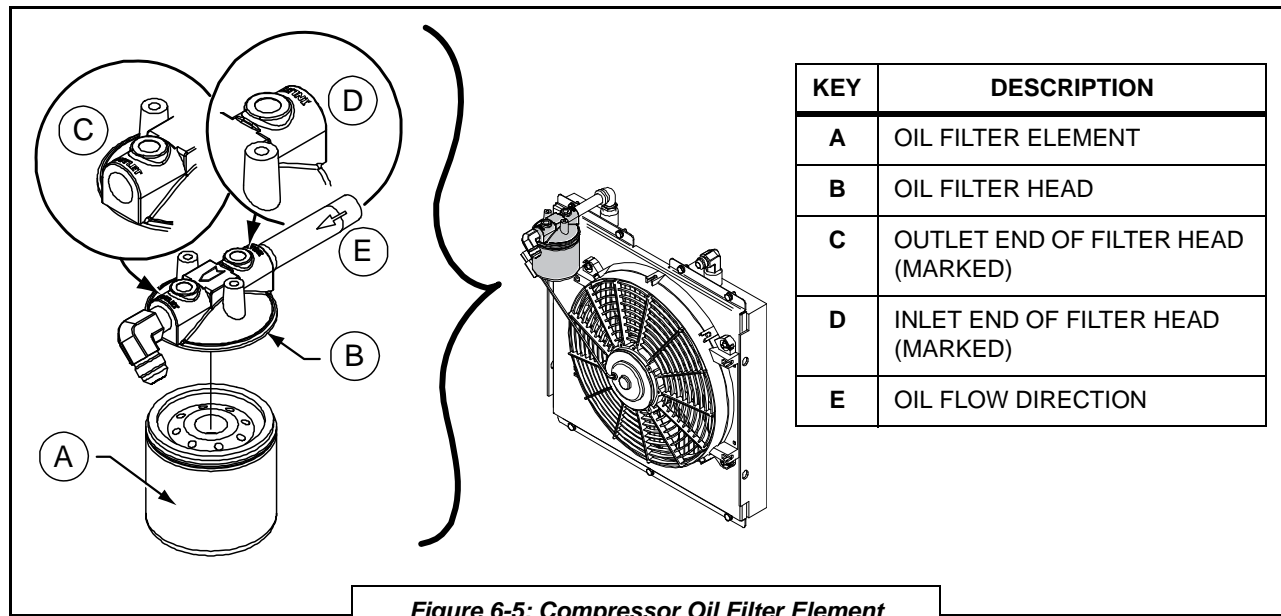

**Figure 6-5: Compressor Oil Filter Element**

1. With the machine off and the ignition key removed, open the hood panel access door.
2. Locate the compressor oil filter, coming off the top of the oil cooler.
3. Remove the worn oil filter element [A] by turning it counterclockwise using a strap wrench.
4. Clean the filter head [B] with a lint-free wiper or cloth. **NOTE:** If filter head needs to be removed, make certain the outlet [C] and inlet [D] coincide with the oil flow direction [E].
5. Apply a light film of compressor oil to the element's [A] sealing surface for an air-tight seal between the element and the filter head [B].
6. Install the new element [A] by manually turning it clockwise onto the filter head [B] until the seal contacts the machined groove on the rim of the filter head. Then turn an additional 3/4 of a turn, using a strap wrench if necessary.
7. Run the compressor and check for leaks.
8. Dispose of discarded filter within the guidelines of all applicable local, regional and/or federal laws.

### NOTE

**If the oil filter element head needs to be replaced, it must be situated to allow for proper flow, as per Figure 6-5. DO NOT install the filter element head in reverse direction.**

**NOTE**

This procedure should only be performed when the compressor is warm immediately after extended operation.

### 6.5.5 CHANGING THE COMPRESSOR OIL

During periodic maintenance intervals, or more frequently if needed, it will be necessary to perform a complete compressor system oil change. Follow the procedure below, along with *Figure 6-6* and *Section 6.5.3*, to change the oil.

TOOLS NEEDED	REPLACEMENT PART(S)
Strap Wrench	Vanair® Vanguard™ Premium Synthetic Oil No. 264626-1/2GAL
Adjustable Wrench	Air/Oil Coalescer Element No. 264154-109
Oil Pan	Oil Filter Element No. 266801

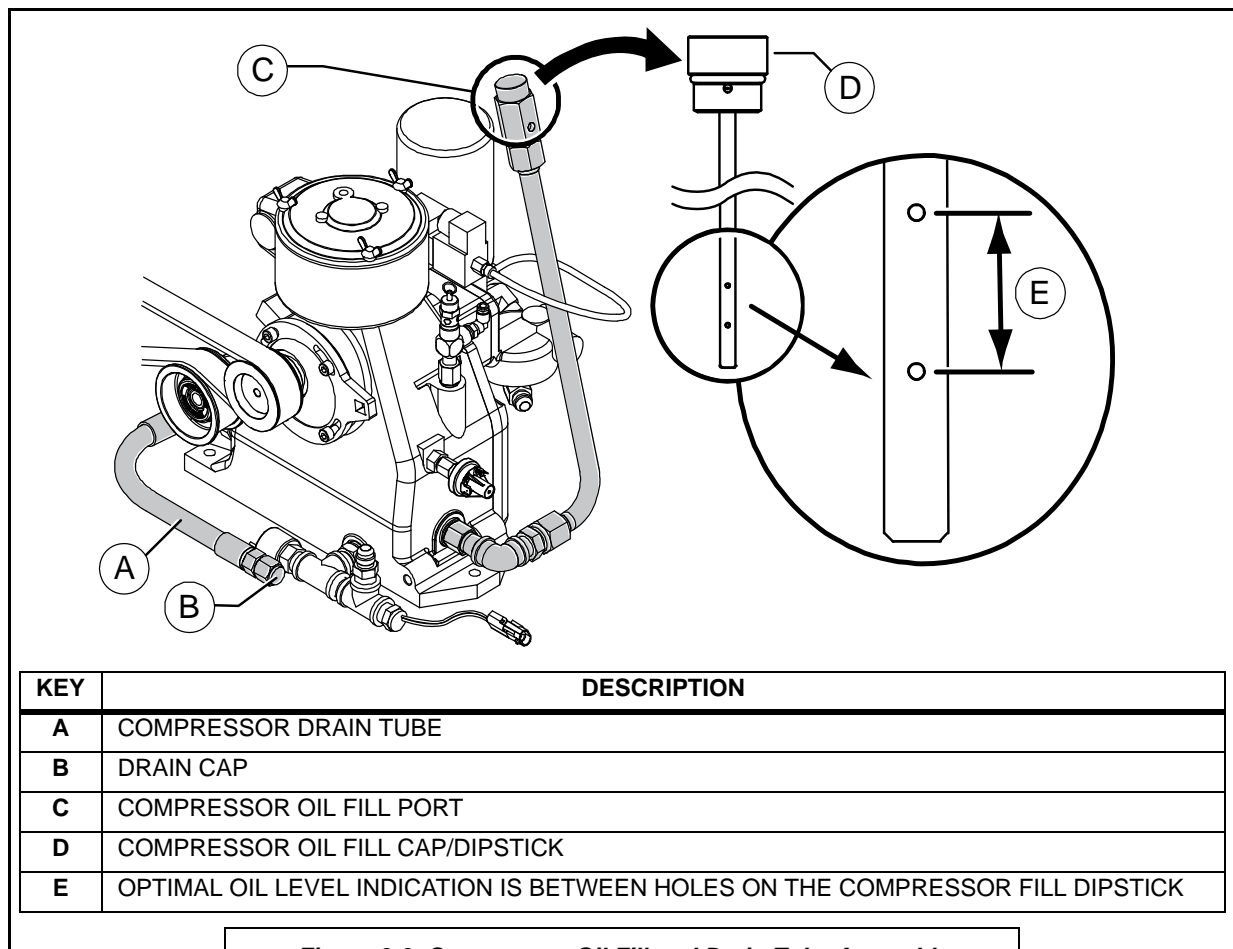

*Figure 6-6: Compressor Oil Fill and Drain Tube Assembly*

1. With the machine off and the ignition key removed, place a suitable receptacle under the compressor drain tube [A] and remove the drain cap [B].
2. After oil has completely drained, securely replace the drain cap [B].
3. Replace the oil filter (see **Section 6.5.4** for instructions on how to replace the compressor oil filter element).
4. Replace the air/oil coalescer (see **Section 6.5.6** for instructions on how to replace the spin-on air/oil coalescer filter).
5. Once the oil filter and air/oil coalescer have been replaced, remove the compressor oil fill cap/dipstick [D], and fill the compressor unit to the service capacity level (two [2] quarts) with Vanguard™ Premium Synthetic Oil.

<b>IMPORTANT</b>
<b>Only Use Vanguard Premium Synthetic Oil.</b>

6. Run the compressor momentarily, turn off, and verify the level of compressor oil [E].

<b>NOTE</b>
<b>DO NOT overfill the compressor system; stay within the recommended guidelines as prescribed in Section 3, Table 3B: Specifications - Air Compressor.</b>

<b>NOTE</b>
For extreme weather conditions, refer to <b>Section 6.7.</b>

### 6.5.6 REPLACING THE SPIN-ON AIR/OIL COALESCER

The air/oil coalescer element is a spin-on disposable type. Consult **Figure 6-7**, and use the following procedure to replace the coalescer element. Consult **Section 6.3, Maintenance Schedule Table** for routine coalescer element change intervals.

<b>TOOLS NEEDED</b>
Strap Wrench
Compressor Oil (to coat seal)

<b>REPLACEMENT PART(S)</b>
Coalescer Replacement Element No. 264154-109

1. With the machine off and the ignition key removed, open the hood panel.
2. Locate the spin-on element situated on the topside at the rear of the compressor unit.
3. Remove the old element by turning counterclockwise using a strap wrench.

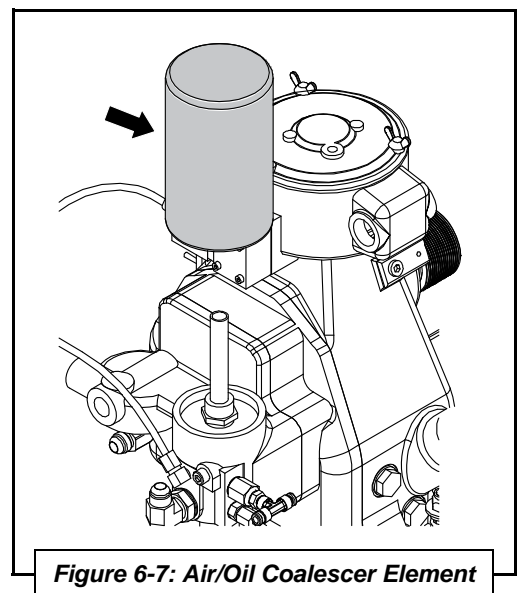

4. Apply a thin film of compressor oil to the new seal supplied with the new element.
5. Place the new seal on the mounting surface of the head.
6. Install the new element into place on the mounting head.
7. Turn element clockwise until it contacts the seal. Rotate one more complete turn, using a strap wrench if necessary.
8. Run the compressor and check for leaks.
9. Dispose of discarded filter within the guidelines of all applicable local, regional and/or federal laws.

**6.5.7 REPAIRING THE COMPRESSOR SHAFT SEAL**

If the air compressor shaft seal requires servicing, order shaft seal repair kit no. 264472.

The compressor belt and compressor drive sheave must first be removed in order to access the seal components. Refer to **Figure 6-8**, and the following procedure to perform maintenance on the compressor shaft seal:

TOOLS NEEDED	REPLACEMENT PART(S)
Wrench - Size 6mm Hex Head	Shaft Seal Rebuild Kit No. 264472
Torque Wrench, 1/2" Drive	
Clean Cloth	
Puller Tool	

**6.5.7.1 PART I – REMOVING THE COMPRESSOR SERPENTINE BELT**

1. With the machine off and the ignition key removed, open the front access panel.
2. Locate the clutch retaining cable [B] secured to the base floor of the machine near the clutch apparatus [A] of the engine.
3. Loosen and remove retaining cable bolt [C], lock washer [D] and washer [E].
4. Slightly loosen the four (4) capscrews [M] enough to allow the compressor sheave (air end) tensioner plate [L] to rotate/slide counterclockwise [Insert L1]. Position the

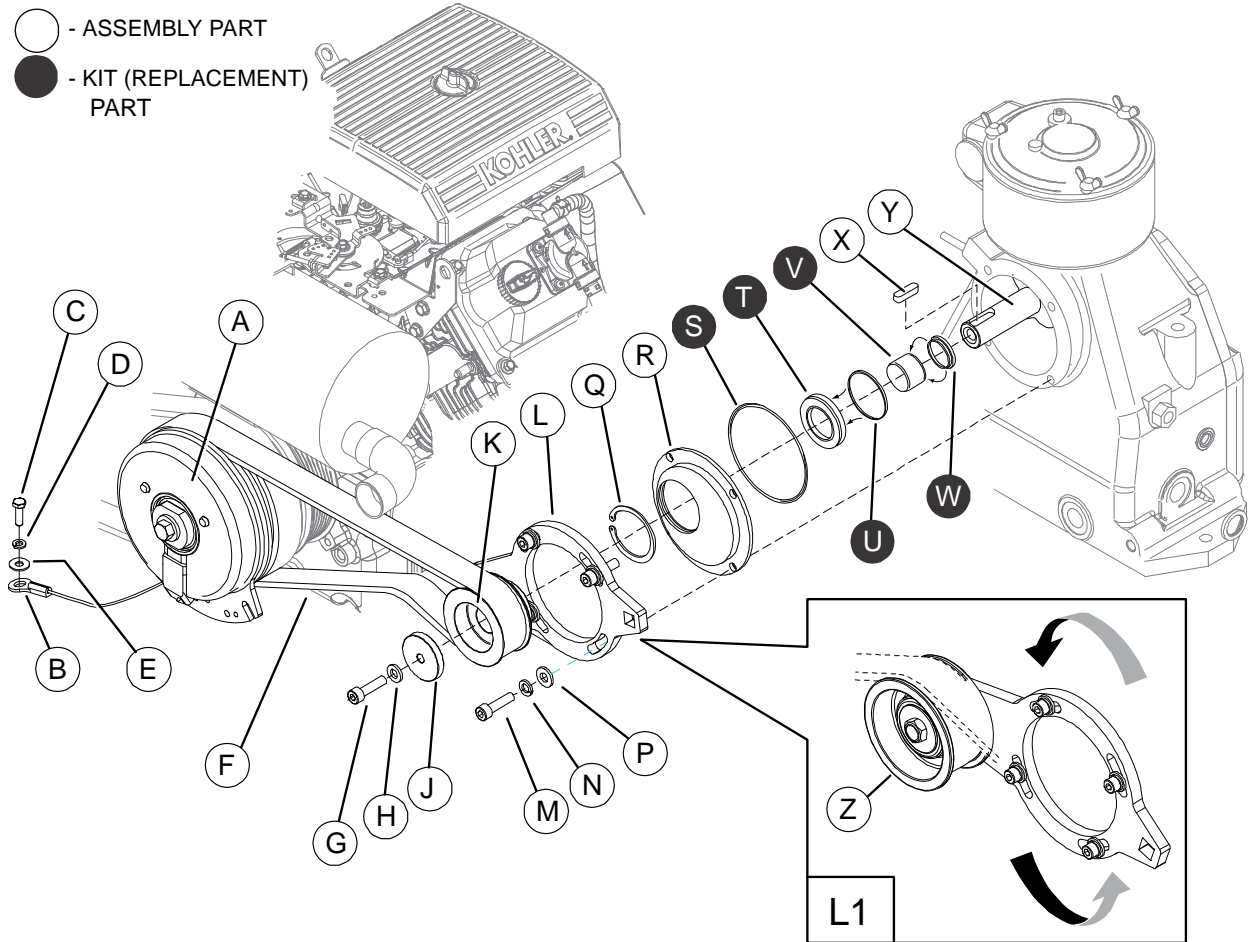

KEY	DESCRIPTION
A	CLUTCH
B	CLUTCH RETAINING CABLE
C	RETAINING CABLE BOLT
D	LOCK WASHER
E	WASHER
F	SERPENTINE BELT (COMPRESSOR)
G	CAPSCREW (M8 x 1.25 x 30MM)
H	WASHER
J	SHEAVE WASER
K	DRIVE SHEAVE
L	AIR END TENSIONER PLATE
L1	TENSIONER PLATE ADJUSTMENT
M	CAPSCREW (M8 x 1.25 x 30MM) (x 4 for Plate L)

KEY	DESCRIPTION
N	LOCK WASHER (M8) (x4 for Plate L)
P	FLAT WASHER (M8) ((x4 for Plate L)
Q	RETAINING RING
R	COMPRESSOR FRONT COVER
S	O-RING
T	SHAFT SEAL RING
U	SEAL O-RING
V	INNER RING
W	SPACER
X	KEY
Y	MALE ROTOR DRIVE SHAFT
Z	COMPRESSER TENSIONER SHEAVE

**Figure 6-8: Compressor Shaft Seal Replacement**

plate enough to allow the serpentine belt [F] to be removed.

5. Remove serpentine belt [F].

### 6.5.7.2 PART II – ACCESSING THE COMPRESSOR UNIT SHAFT SEAL

1. Loosen and remove the four (4) M8 capscrews [G], and also the washers [H], and sheave washers [J] securing drive sheave [K] into place.
2. Remove the drive sheave [K] from the end of the male rotor drive shaft [Y].
3. Remove key [X] from the groove in the end of the male rotor drive shaft [Y].
4. Remove the retaining ring [Q] from the end of the male rotor drive shaft [Y].
5. Remove the four (4) capscrews [M], lock washers [N], and flat washers [P] securing the tensioner plate [L] and front cover [R] to the front of the compressor unit.
6. Remove the front cover [R] to expose the seal assembly. Remove the worn shaft seal ring [T], seal o-ring [U], inner ring [V], and spacer [W] from the end of the male rotor drive shaft [Y].
7. Wipe down any excess contaminants that may have accumulated on the male rotor drive shaft.
8. Replace spacer [W] with its new counterpart from the kit.
9. Replace inner ring [V] with its new counterpart from the kit; the inner ring should be gently tapped into place using the tool as a guide. Note that it should seat snugly on the spacer [W].
10. Replace metal seal o-ring [U] within the lip-end of the new shaft seal ring [T] (both parts from the kit).
11. Gently tap the shaft seal ring [T] onto the male rotor [Y].

#### NOTE

Before attempting to affix the seal to the shaft, make note that the lip-end side of the shaft seal (which contains the seated metal seal o-ring [U]), faces the rotor.

12. When the edge of shaft seal ring [T] is flush with the inner ring [V] on the shaft, the shaft seal is in position.
13. Lubricate o-ring [S] with the silicon lubrication supplied with the kit.
14. Place o-ring [S] within the groove on the inside of the compressor cover [R].

<b>NOTE</b>
<b>If present, scrape off any remnant pieces of previous gasket from the compressor cover [R] before replacing o-ring.</b>

15. Place the compressor cover [R] over its seating position on the compressor unit body.
16. Place the compressor tensioner plate [L] so that its holes line up with the compressor cover [R].
17. Fit a lock washer [N] and flat washer [P] over an M8 capscrew [M], and place it through one of the upper aligned holes of the tensioner plate and compressor cover. Screw it into place snugly, but not fully tightened.
18. Repeat Step #17 for the three remaining holes until the aligned tensioner plate [L] and compressor cover [R] are secured snugly to the compressor unit. Do not tighten the capscrews, as the tensioner plate will have to be adjusted to allow for repositioning of the tensioner sheave/serpentine belt.
19. Replace retaining ring [Q] into its seating groove on the outer side of the compressor cover [R].

### 6.5.7.3 PART III – REPLACING THE COMPRESSOR SERPENTINE BELT

1. Replace/re-thread the serpentine belt [F] back onto the engine sheave and drive sheave [K], making sure that the belt lies over the compressor tensioner sheave [Z] (as shown in insert L1).
2. For details on how to adjust the compressor belt tension, consult **Section 6.5.16.1, Retensioning the Air Compressor Serpentine Belt**. Note that if either of the serpentine belts driving the compressor or

the generator needs to be replaced, then both should be replaced at the same time (consult entire **Section 6.5.16** in this Operator's Manual and Parts List).

### **6.5.8 REPLACING THE AIR INLET SOLENOID VALVE**

If an air inlet valve malfunction is caused by a faulty solenoid signal, the solenoid will need to be replaced. Order air inlet valve replacement kit no. 264154-078. Refer to **Figure 6-9**, and the following procedures:

#### **6.5.8.1 SOLENOID VALVE – PREPARATION BEFORE MOUNTING**

Before installing the new solenoid, the connector's base needs to be rotated so that the connector situates correctly with the wire direction once it is plugged into the solenoid block. To achieve the correct connector base configuration:

1. Unpack the new solenoid valve from the kit packaging.
2. Unscrew the screw [A] securing the connector head [B] to the valve body [G], and gently pull the connector away from the solenoid block's connection pins.
3. Remove the seal [D].
4. Set the solenoid block aside, taking care not to bend or damage the three connector pins [E].
5. Insert a screwdriver into the access indent on the base [K]. Apply prying pressure to the pry slot [L], so that the base comes away from the connector head (shown in [M]).
6. Rotate the base so that the slit corresponding to the only flat pin is closest to the wire connection end of the valve connector head, as shown in [N].
7. Hold connector and with your thumbs, push the base into the connector head until it snaps into place [P]. Base should be flush with the connector head to assure a good seating.
8. Replace the seal [D] over the pins [E] on the valve body.
9. Gently push the connector head [B] onto the valve body; the pins will now align the collar side [C] of the connector head so that it



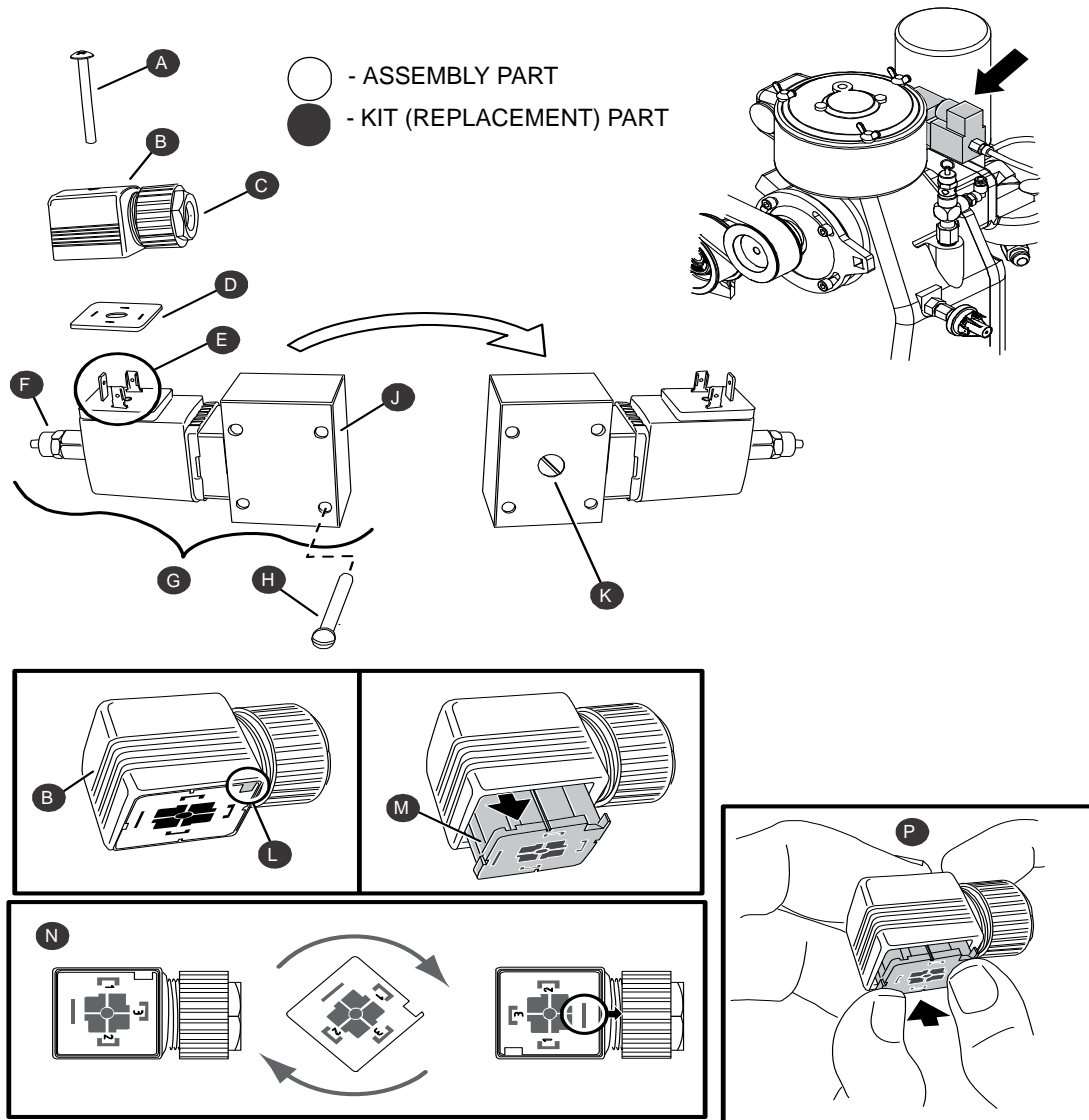

KEY	DESCRIPTION	KEY	DESCRIPTION
A	SCREW	H	MOUNTING SCREW (x 4)
B	CONNECTOR HEAD <sup>‡</sup>	J	VALVE MOUNTING BLOCK
C	SET COLLAR (CONNECTOR HEAD) <sup>‡</sup>	K	INLET-SIDE SCREW
D	SEAL	L	PRY SLOT
E	CONNECTION PINS	M	CONNECTOR HEAD BASE
F	PNEUMATIC TUBE CONNECTOR <sup>‡</sup>	N	PIN RE-CONFIGURATION
G	VALVE BODY	P	SEATING THE CONNECTOR BASE

<sup>‡</sup>Not used - discard.

**Figure 6-9: Air Inlet Valve Solenoid Replacement**

points away from the valve mounting block [J] side of the valve body.

### 6.5.8.2 CONNECTING THE NEW SOLENOID VALVE

Refer to **Figure 6-9** and the following procedure:

1. With the machine off and the ignition key removed, open the hood panel and locate the inlet valve solenoid mounted beneath the compressor air filter.
2. Unscrew the top securing screw [A] of the valve connected to the unit, and gently pull the connector away from the solenoid block's connection pins.
3. Remove the wires connected to the valve connector head [B] by unscrewing the collar [C] securing the wires in place.
4. Remove the collar from the pneumatic tube connection [F] to separate the tube from the body.
5. Remove the four (4) screws [H] securing the solenoid block to the unit.
6. Position the new solenoid valve body so that the four (4) mounting holes of the valve body align with the four (4) holes on the unit mounting surface. Note that the screw [K] side of the new valve faces into the compressor unit.
7. Use the four (4) mounting screws from the kit [H] to secure the new valve body to the compressor unit.
8. Unplug the connector head from the new solenoid body, but leave the seal in place.
9. Unscrew the collar [C] from the new connector head.
10. On the wire, replace the old connector collar with the new one from the new connector head.
11. Run the collar up the wire, and secure it to the valve connector head.
12. Position the connector head onto the valve body making sure the pins align correctly before applying pressure.

13. Connect the pneumatic tube [F] to the new valve body.
14. Test the unit to assure that the valve is working properly.

### 6.5.9 DRAINING THE AIR TANK

Refer to **Figure 6-10**. The air tank reservoir may accumulate a moisture build-up on the inside due to the compression of air. The air tank should be checked daily and allowed to drain by opening the drain cock on the ball valve located at the lower right corner of the base frame on the back end of the machine. For areas of high ambient moisture content the valve may need to be checked more than once per day. This valve may be accessed at any time, including while the machine is in operation.

**NOTE**

If operating the machine in high humidity, the drain valve can be left partially open to relieve water build-up during operation. This water may contain a small amount of oil.  
**Auto drain kit is available from Vanair®. Consult Section A.5, for order number.**

**NOTE**

The 1/4" NPT fitting at the end of the drain valve can be piped to a holding tank.

TOOLS NEEDED
Catch Tray or Cloth to Absorb Drained Moisture

REPLACEMENT PART(S)
Not Applicable

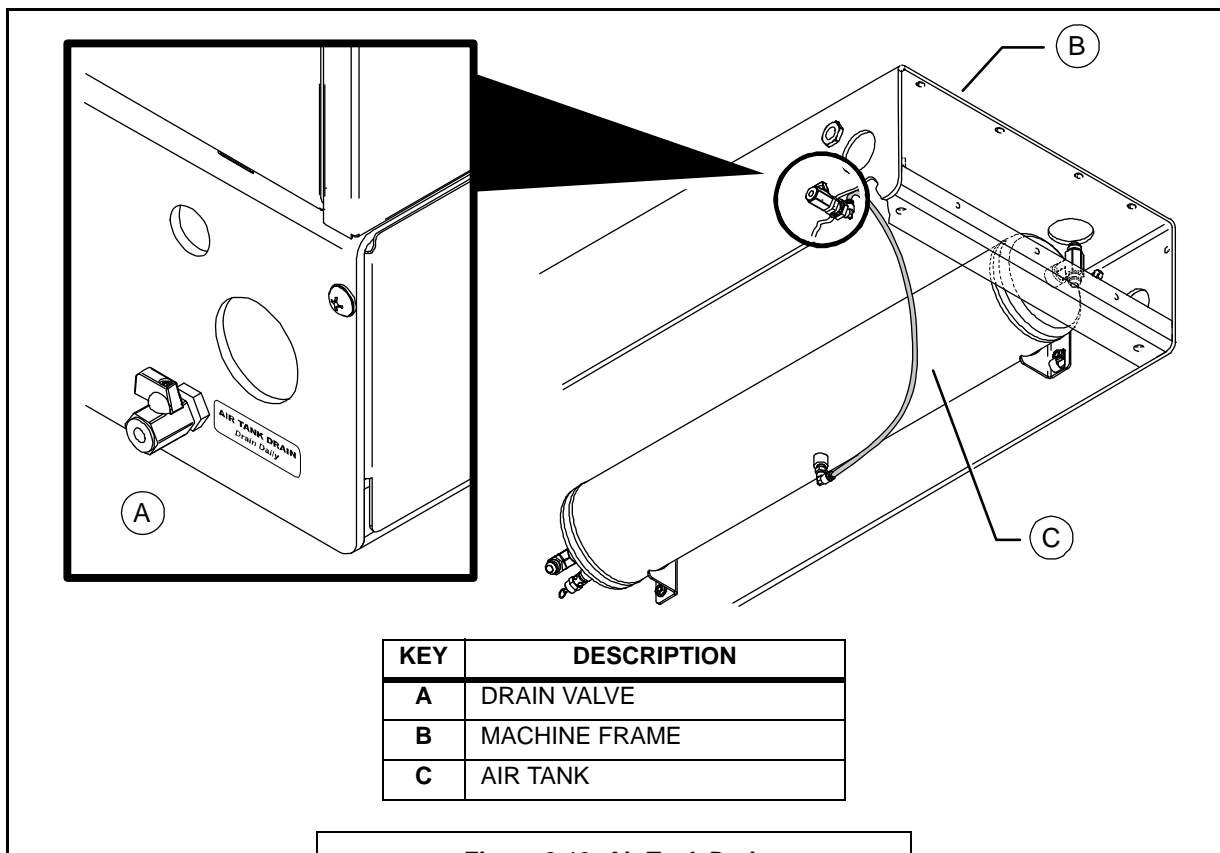

**Figure 6-10: Air Tank Drain**

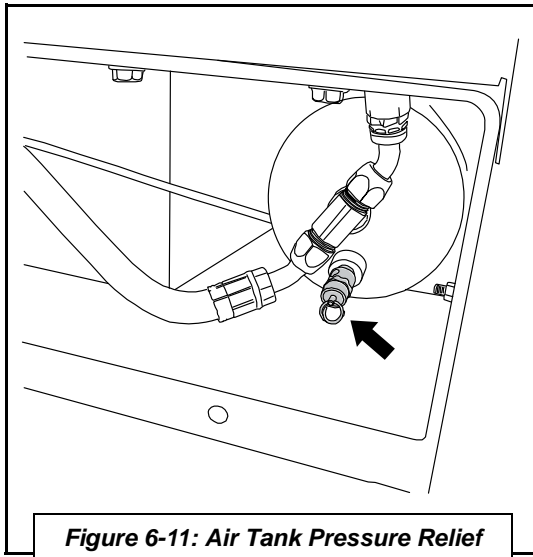

**Figure 6-11: Air Tank Pressure Relief Valve**

1. Turn handle of drain valve [A] to release moisture buildup. If preferred, place a container below the valve to catch discharge.
2. Close the valve after the water has drained off.

**6.5.10 CHECKING THE AIR TANK RELIEF VALVE**

The pressure relief valve on the air tank should be tested frequently to assure proper operating condition. To test the relief valve, see **Figure 6-11**, and use the following procedure:

Note: the tank must have a quantity of air in order to test the relief valve.

1. Locate the valve at the end of the air tank.
2. Grasp the ring and pull; when working properly, a hissing sound of escaping air will be heard.
3. Let go of the ring; the valve should automatically reset into its containment position, and the hissing sound should stop.

**NOTE:** If a hissing sound of escaping air is persistent, and the valve will not reset, replace the valve.

**6.5.11 REBUILDING THE MINIMUM PRESSURE/CHECK VALVE**

Should a condition occur that requires the minimum pressure/check valve to be serviced (see **Section 7.2, Troubleshooting Guide**), a repair kit is available. To repair the minimum pressure/check valve, order minimum pressure/check valve kit no. 264154-106. Refer to **Figure 6-12**, and the following procedure:

TOOLS NEEDED
Clean Cloth

REPLACEMENT PART(S)
Minimum Pressure/Check Valve Rebuild Kit No. 264154-106

1. With the machine off and the ignition key removed, open the hood panel.
2. Locate the minimum pressure/check valve [A] situated under the coalescer element on the compressor unit.

3. Loosen and remove the lock nut [B] securing the grub screw [C] in position.
4. Loosen the grub screw [C] to relieve any spring tension in the valve.
5. Loosen and carefully remove the valve body [D], which holds the internal parts in place. The internal parts will be freed to drop out with the removal of the valve body.
6. Wipe internal surface of valve body [D] with a clean cloth.
7. Consult **Figure 6-12**, and re-assemble the kit by replacing all old parts with corresponding part provided in the kit.
8. Once the kit parts (parts E through L) have been situated in correct order into the valve

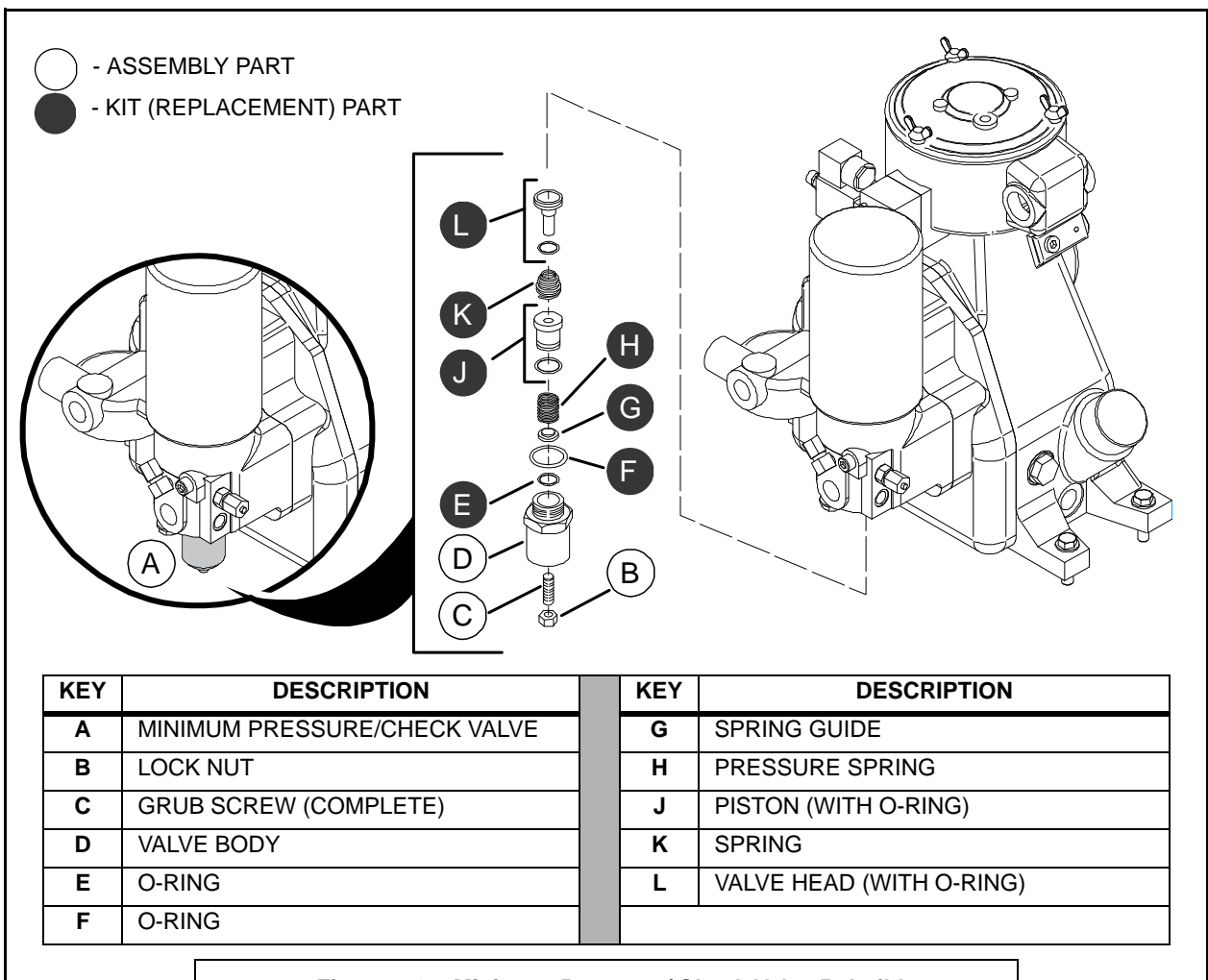

Figure 6-12: Minimum Pressure / Check Valve Rebuild

body, replace the valve body back into the mounting position. Retighten body securely.

9. Replace the grub screw [C] into position on valve body [D], and hand-tighten. Replace the lock nut [B] over the grub screw, and position it loosely over the grub screw.

**6.5.11.1 SETTING THE MINIMUM PRESSURE VALVE**

1. Start the machine and allow it to assume idle speed.
2. Start the compressor and allow it to accumulate pressure build-up.
3. Using the panel pressure gauge as a guide, adjust the grub screw [C] until minimum pressure level is achieved.
4. Tighten the lock nut [B] to secure the grub screw at the proper minimum pressure level.

**6.5.12 INSPECTING THE SYSTEM COOLERS**

Refer to **Figure 6-13**. Periodically as per **Section 6.3, Maintenance Schedule Table**, inspect the cooler fins of both the engine and the compressor for any build up of dirt or contamination. Should any residue appear during inspection, clear with the use of air blown across the surface of the cooler fins.

**6.5.13 CHECKING THE ENGINE OIL**

Refer to **Figure 6-14**. The engine oil level is checked often and periodically as per the maintenance schedule intervals suggested in **Section 6.3, MAINTENANCE SCHEDULE TABLE**. Check the engine oil level when the engine is off, and the oil allowed to settle.

<b>NOTE</b>
Use only low pressure air to clean the cooler fins. DO NOT use high pressure air or a pressure washer.

<b>NOTE</b>
Refer to the Engine Operator’s Manual for detailed maintenance and replacement procedures for the engine.

<b>TOOLS NEEDED</b>
Clean Cloth

<b>REPLACEMENT PART(S)</b>
Engine Oil <sup>I</sup>

<sup>I</sup> Engine may need additional amount of oil if low. Consult Engine Operator’s Manual for oil grade used, amount needed, and oil change intervals.
---

1. Locate the engine dipstick handle [A] and remove.

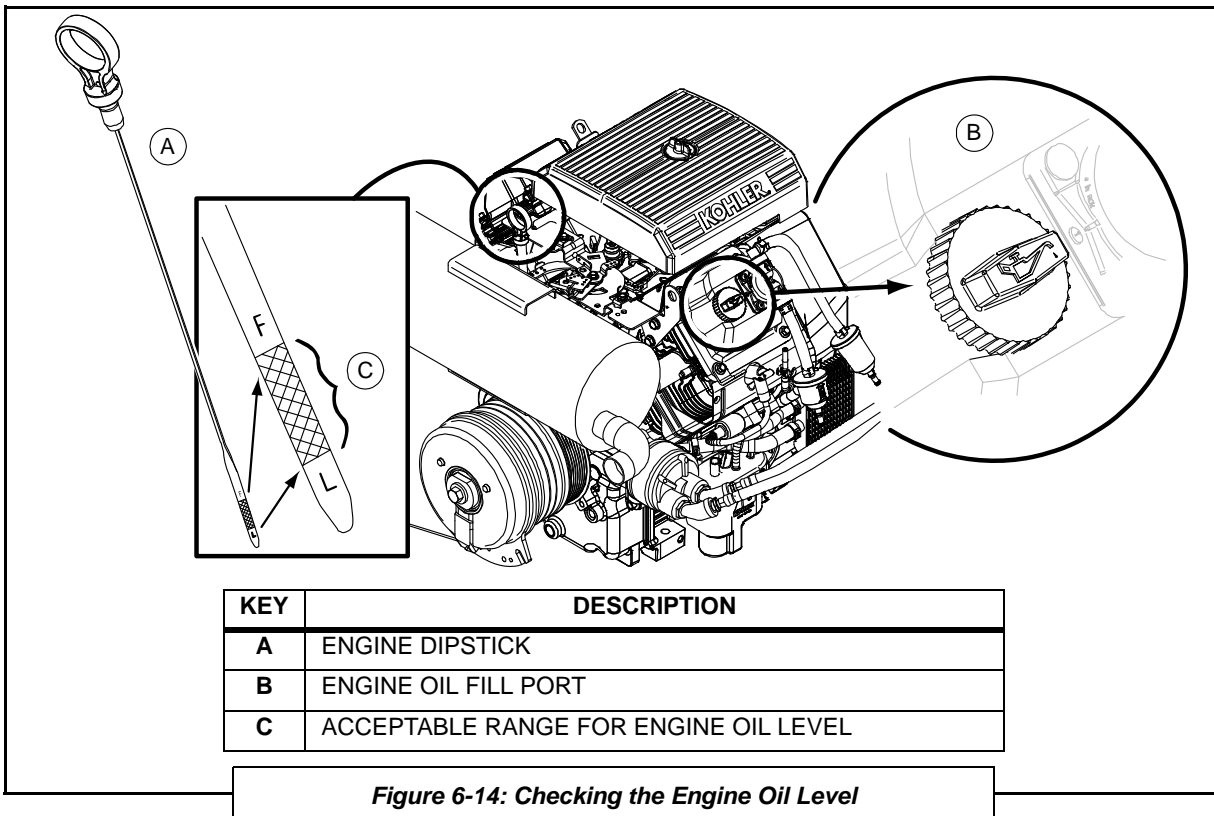
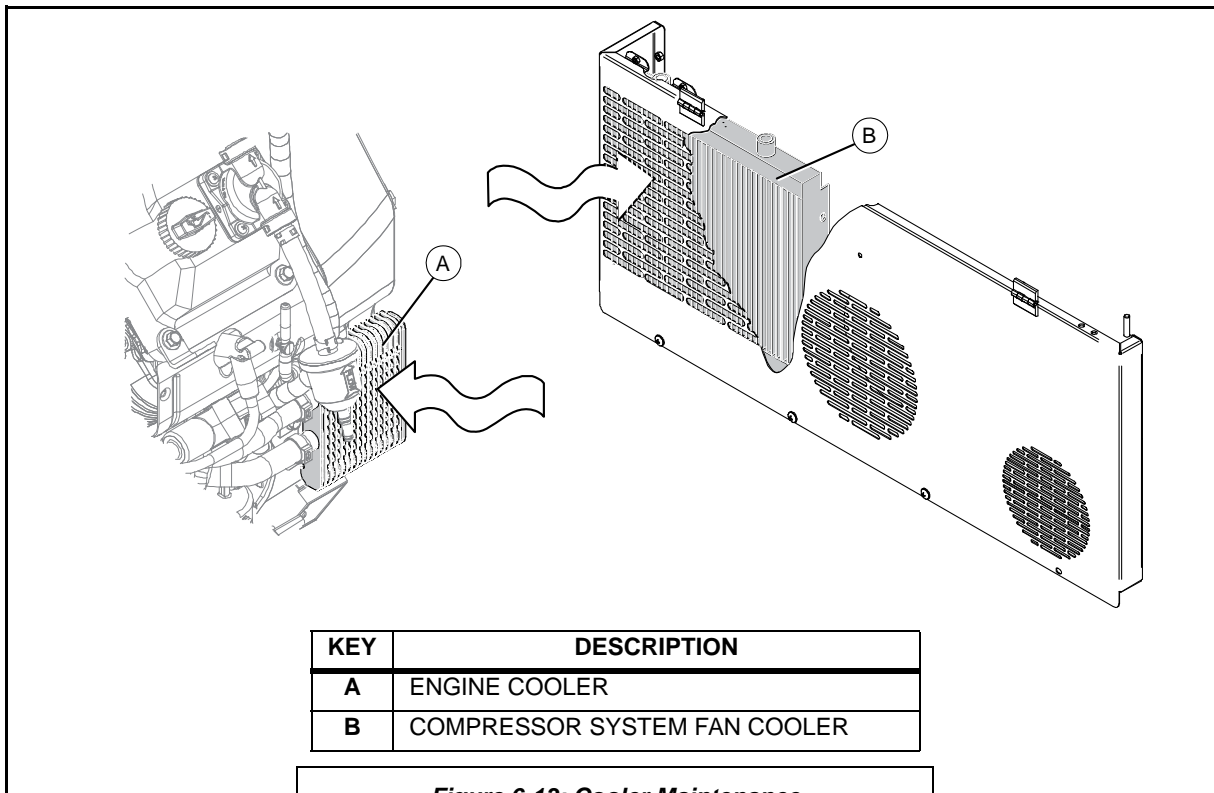

2. Wipe off the excess oil on the dipstick blade, and replace the dipstick back into the engine tube in order to get a clear level reading.
3. Remove the stick again, and observe where the oil level shows at the gauge-end of the stick [C].

The level should be somewhere between the “F” and “L” on the stick. If the level shows low, replenish with the same type of engine oil currently being used to achieve a satisfactory level, by adding oil at engine oil fill port [B].

If the engine is due for an oil change, or if operating conditions require more frequent change intervals than the normal routine maintenance schedule given in this section, consult the Engine Operator’s Manual for oil change scheduling, and the procedure on how to change the engine oil.

#### 6.5.14 ADJUSTING THE ENGINE SPEED

Consult Vanair Service Department for issues relating to adjustment of engine speed.

**NOTE**

**Do not tamper with the governor setting to increase the maximum engine speed. Overspeed is hazardous and will void the engine warranty. The maximum allowable high idle speed no load for these engines is 4200 RPM.**

#### 6.5.15 ADJUSTING THE PRESSURE SETTING

 **WARNING**

**The compressor cut-in/cut-out pressures have been factory-adjusted within the limits of the compressor manufacturer. The maximum pressure limit of the compressor is 175 PSI. Pressure should never be allowed to go beyond this limit or what has been set by local laws and regulators. This system will disengage the clutch at 185 psi. A 200 PSI safety relief valve is located on the air tank to prevent over pressurizing the system.**

The **Cut-in pressure** is defined as the pressure in which the compressor starts pumping. Anytime the pressure in the tank falls below this pressure the compressor is allowed to start pumping.

The **Cut-out pressure** is defined as the pressure in which the compressor stops pumping. When the pressure in the air tank rises above this pressure the compressor is signaled to stop pumping.

Pressure settings for both the minimum and maximum rated capacity levels for this machine are adjusted at the factory before shipping, and should not need to be adjusted. However, a situation may occur where it is necessary to manually adjust or reset either or both of



these settings. For such cases, consult *Figure 6-15*, and the following procedure:

TOOLS NEEDED
Screw Driver

REPLACEMENT PART(S)
Not Applicable

**NOTE**

There must be a minimum of 25 psi difference between the cut-in and cut-out pressures for the system to operate properly.

**WARNING**

Pressure settings (both minimum and maximum) are pre-secured within the rated capacity levels for this machine at the factory before shipping. However, it may be necessary to manually adjust. **NEVER** adjust the pressures beyond the recommended or rated capacity specified for the machine.

1. Locate the air pressure control switch [B] at the right of the battery bracket [A]. Remove the cover retaining screw [D] fastening the cover to the switch, and remove the cover [C].

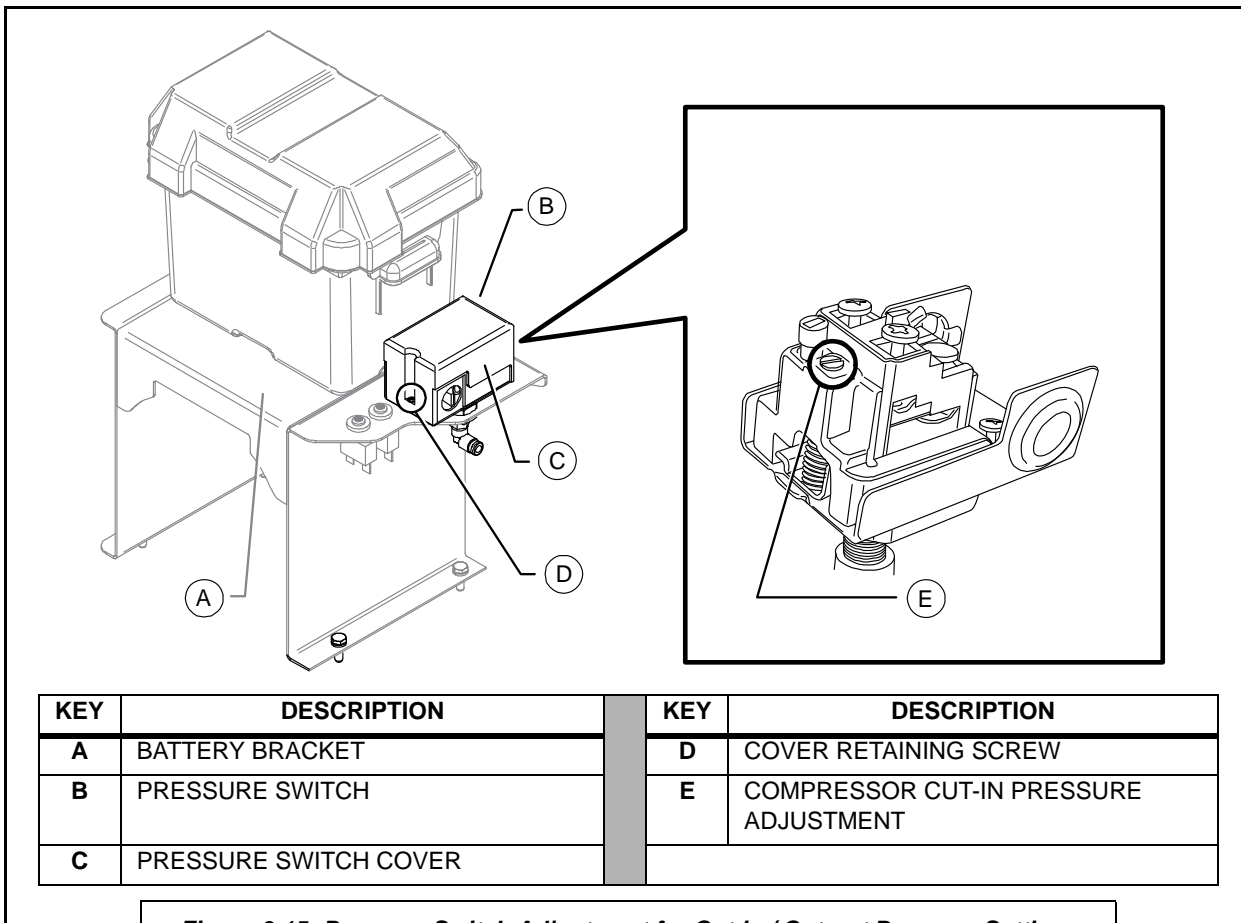

**Figure 6-15: Pressure Switch Adjustment for Cut-in / Cut-out Pressure Settings**

2. To adjust the compressor pressure, turn the adjustment screw [F] clockwise to increase the pressure and counterclockwise to lessen the pressure.
3. After making your adjustments, position and fasten the cover [C] to the pressure switch body.
4. Close the hood, and cycle the compressor several times to ensure the correct pressures are set.
5. If additional adjustments are needed, repeat steps one through six until the correct pressures are set.

### 6.5.16 REPLACING AND RE-TENSIONING THE SERPENTINE DRIVE BELTS

The compressor and generator are driven by the engine using two belts. The belts will generally not need replacement during the service life of the compressor system. However, you may find that over time they become loose and need to be tightened. The proper tension can be determined by using a tension tester to measure the deflection from a given force.

<b>NOTE</b>
<p>Proper alignment of all pulleys on the serpentine belt is crucial. A chirping or squeaking sound, noticeable after replacing the belts, may indicate an alignment problem. Always inspect and replace the belts as recommended in the maintenance section of this manual.</p> <p>Misalignment of the V-belts can cause unnecessary jumping and wear of the belt, resulting in the belt coming off.</p>

<b>NOTE</b>
<p>Vanair® recommends that the air compressor and generator serpentine belts both be changed at the same time even if only one of the belts is in need of being changed.</p>

#### 6.5.16.1 RE-TENSIONING THE AIR COMPRESSOR SERPENTINE DRIVE BELT

Consult *Figure 6-16*, and the following procedure:

<b>TOOLS NEEDED</b>
<p>Wrench - Size 6mm Hex Head</p> <p>Torque Wrench, 1/2" Drive</p>

<b>REPLACEMENT PART(S)</b>
<p>Not Applicable</p>

1. With the machine off and the ignition key removed, open and remove the front panel.
2. Loosen the four tensioner plate bolts [A] mounting the tensioner plate [C] to the compressor only enough to allow tensioner

	<b>WARNING</b>
<p>Never operate the machine with the rear door removed.</p>	

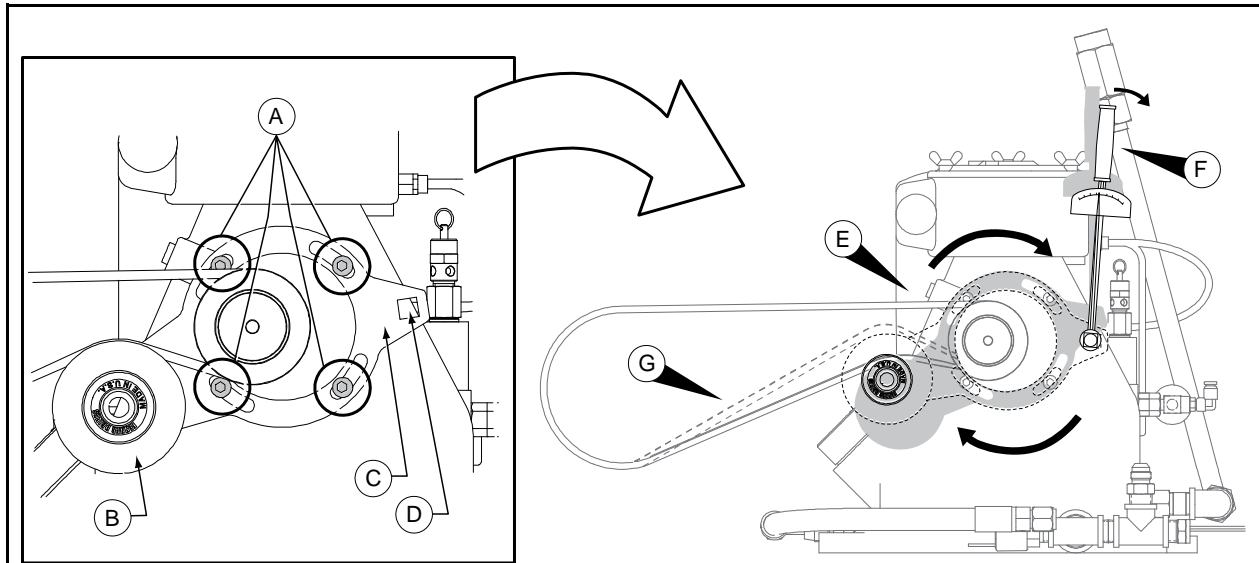

KEY	DESCRIPTION	KEY	DESCRIPTION
A	TENSIONER PLATE MOUNTING AND ADJUSTMENT BOLTS	E	Loosen bolts to allow tensioner plate to pivot manually to achieve new belt-tensioned position.
B	IDLER	F	Pivot plate by applying torque wrench to tensioning hole.
C	TENSIONER PLATE	G	Belt tension adjustment should be verified using a tension tester.
D	TENSIONING HOLE		

**Figure 6-16: Compressor Serpentine Belt Re-tensioning**

- plate to rotate/slide along the grooves in the plate while still in position (**DO NOT** remove).
- Use a 1/2" drive torque wrench applied to the square tensioning hole [D] to manually rotate the plate/idler about the loosened, but anchored, mounting bolt. Apply torque of 51 in-lbs as per **Table 6B: Measuring Belt Deflection** for the proper tension measurement.
  - Once a position is achieved that accounts for a satisfactory tension in the belt, torque the four (4) tensioner plate bolts [A] to 12 ft-lbs (16.3 Nm) to secure the tensioner into position.

**NOTE**

If new belts are installed, recheck the tension after 10-20 hours of operation, and adjust if necessary.

**IMPORTANT**

Excessive loosening of mounting bolts [A] to free the tensioner plate will cause oil to leak.

Compressor seal may leak oil during the adjustment of the tensioner plate. Check compressor oil level after the adjustment has been made and the bolts have been re-tightened.

TABLE 6B: MEASURING BELT DEFLECTION					
		<p><b>P - Span Length</b>  <b>c - Center Distance</b>  <b>F - Deflection Force</b>  <b>q - Deflection Distance</b></p>			
SPAN LENGTH (in)	DEFLECTION DISTANCE (in)	DEFLECTION FORCE (lbs)			
		ALL RIBS		TORQUE TO IN-LB TENSION	
		RE-TENSION	NEW INSTALL	RE-TENSION	NEW INSTALL
14.286	0.223	10.725	17.074	51	79

### 6.5.16.2 REPLACING THE AIR COMPRESSOR SERPENTINE DRIVE BELT

To replace the air compressor serpentine belt consult **Figures 6-17** and **6-18**, and the following procedure:

TOOLS NEEDED	REPLACEMENT PART(S)
<p>Socket Wrench - Size 6 mm Hex Head (for Tensioner Plate Bolts)</p>	<p>Serpentine Belt No. DR270054</p>
<p>Torque Wrench, 1/2" Drive</p>	
<p>Ratchet, 1/2" with Extension</p>	

1. With the machine off and the ignition key removed, open and remove the front panel.
2. Locate the clutch retaining cable ([F] in **Figure 6-17**) secured to the base floor of the machine near the clutch apparatus of the engine.
3. Loosen and remove the clutch retaining cable [F], lock washer [D], and washer [E] securing the cable to the floor.
4. Position and route the new air compressor serpentine belt as shown in **Figure 6-18**, making sure that it goes on the outside of the double sheave track on the engine clutch assembly.

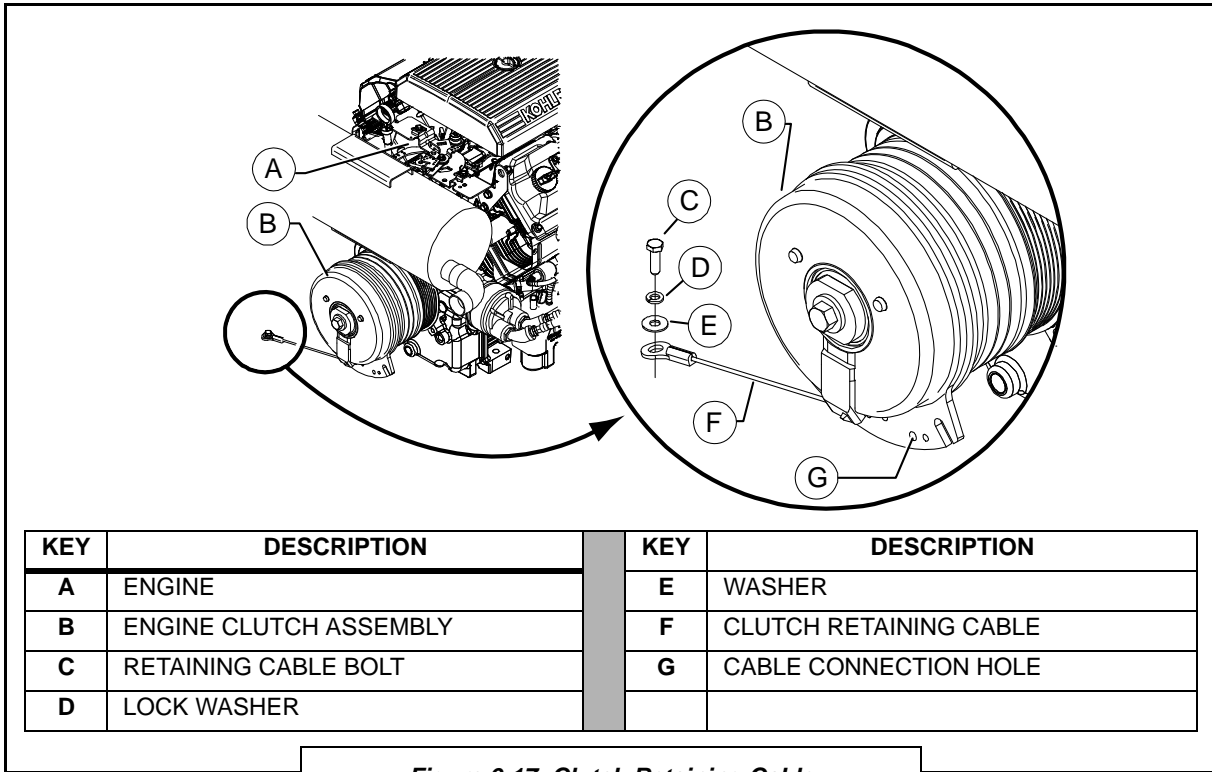

Figure 6-17: Clutch Retaining Cable

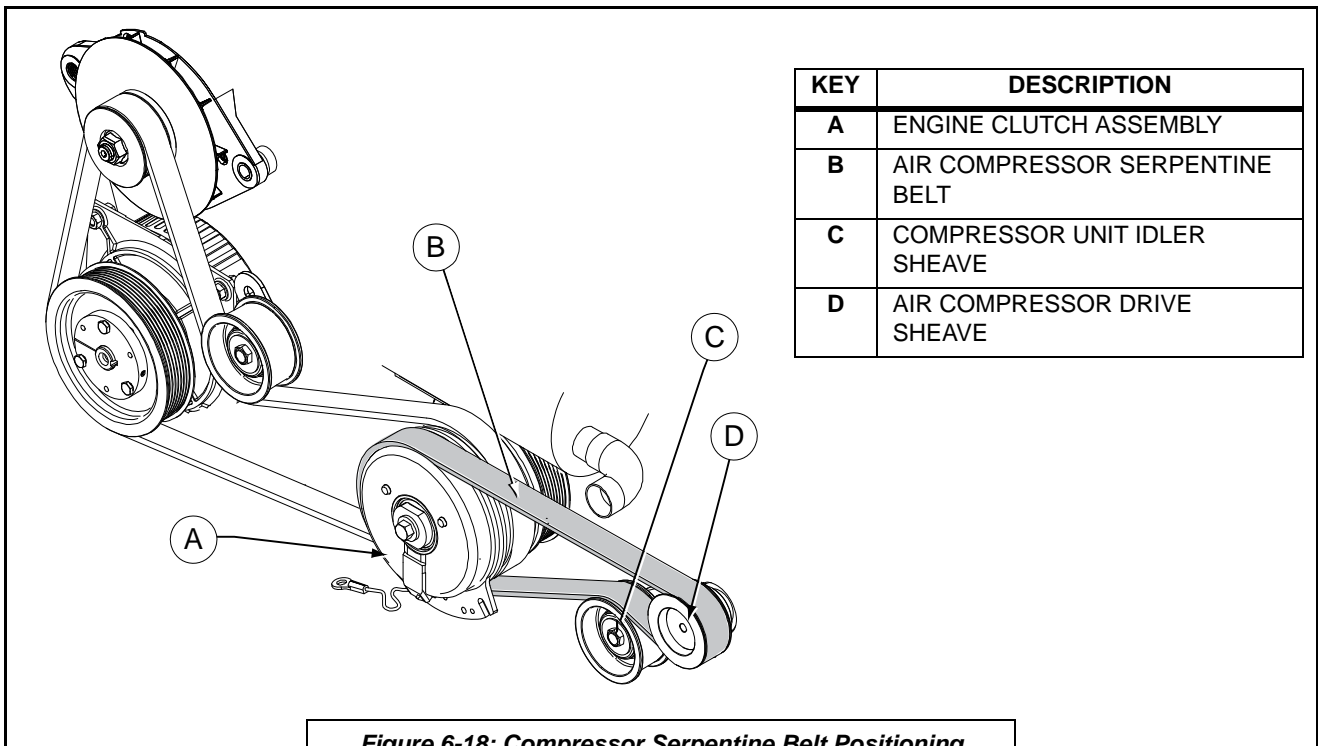

Figure 6-18: Compressor Serpentine Belt Positioning

- Replace the washer [D] and nut [A]. Tighten the nut securely.

<b>NOTE</b>
After replacing the serpentine belt, the belt will need to be checked for proper tension. Consult Section 6.5.15.1 on how to check and adjust the air compressor serpentine belt tension.

**6.5.16.3 RE-TENSIONING THE GENERATOR SERPENTINE BELT**

To re-tension the generator serpentine belt, consult *Figure 6-19* and the following procedure:

TOOLS NEEDED	REPLACEMENT PART(S)
Wrench - Size 3/8"	Not Applicable
Tension Tester	

- With the machine off and the ignition key removed, open and remove the front panel.
- Locate the generator belt idler sheave [A] on the generator tensioner plate [B]. Loosen, but do not remove, the tensioner plate mounting and adjustment bolt [C]. Loosen enough to allow the tensioner plate to pivot while still retaining belt path position.
- Vanair recommends rotating the tensioner plate to its maximum position.**
- Once the position is achieved that accounts for a satisfactory tension in the belt, torque the bolt [C] to 12 ft-lbs (16.3 Nm) to secure the tensioner plate [B] into position.

**6.5.16.4 REPLACING THE GENERATOR SERPENTINE DRIVE BELT**

TOOLS NEEDED	REPLACEMENT PART(S)
Wrench - Size 15/16" (for Tensioner Plate Bolts)	Serpentine Belt No. DR98202
Tension Tester	
Socket Wrench - Size 3/4"	

To replace the generator serpentine belt consult *Figures 6-18, 6-19* and *6-20*, and the following procedure:

- With the machine off and the ignition key removed, open and remove the front access panel.

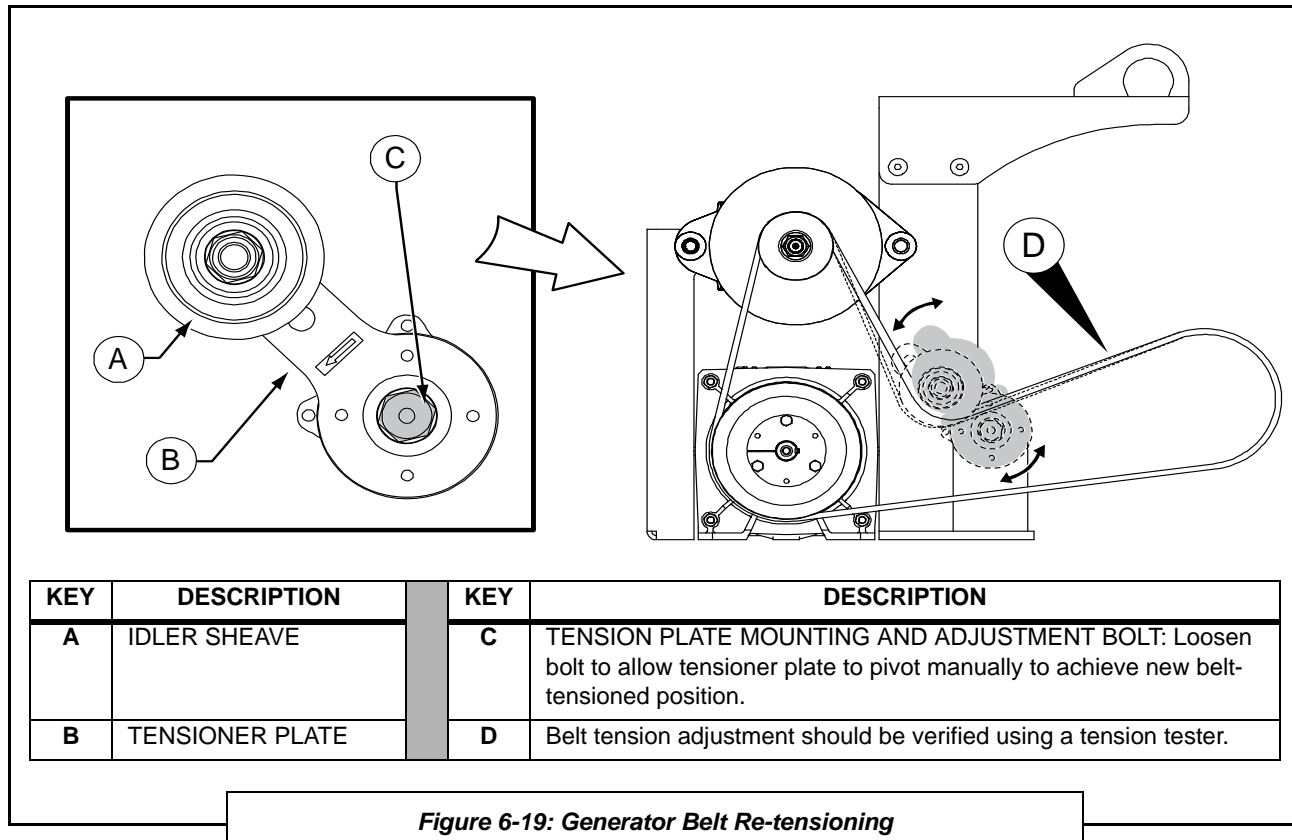

2. Locate the clutch retaining cable ([F] in **Figure 6-18**) secured to the base floor of the machine near the clutch apparatus of the engine.
3. Loosen and remove the clutch retaining cable [F], lock washer [D], and washer [E] securing the cable to the floor. Retain parts for reassembly.

After removing the air compressor serpentine belt ([F] in **Figure 6-20**; refer to **Section 6.5.15.2** for compressor serpentine belt replacement), The worn generator serpentine belt can now be replaced. Refer to **Figure 6-20** and the following steps:

4. Using a 3/4" socket wrench on belt pulley [C] nut, pivot the belt tensioner [G] to relieve enough tension on the sheave [C] in order to remove the belt [D].
5. Position and route the new generator serpentine belt as shown in **Figure 6-20**, making sure that it goes on the inside of the

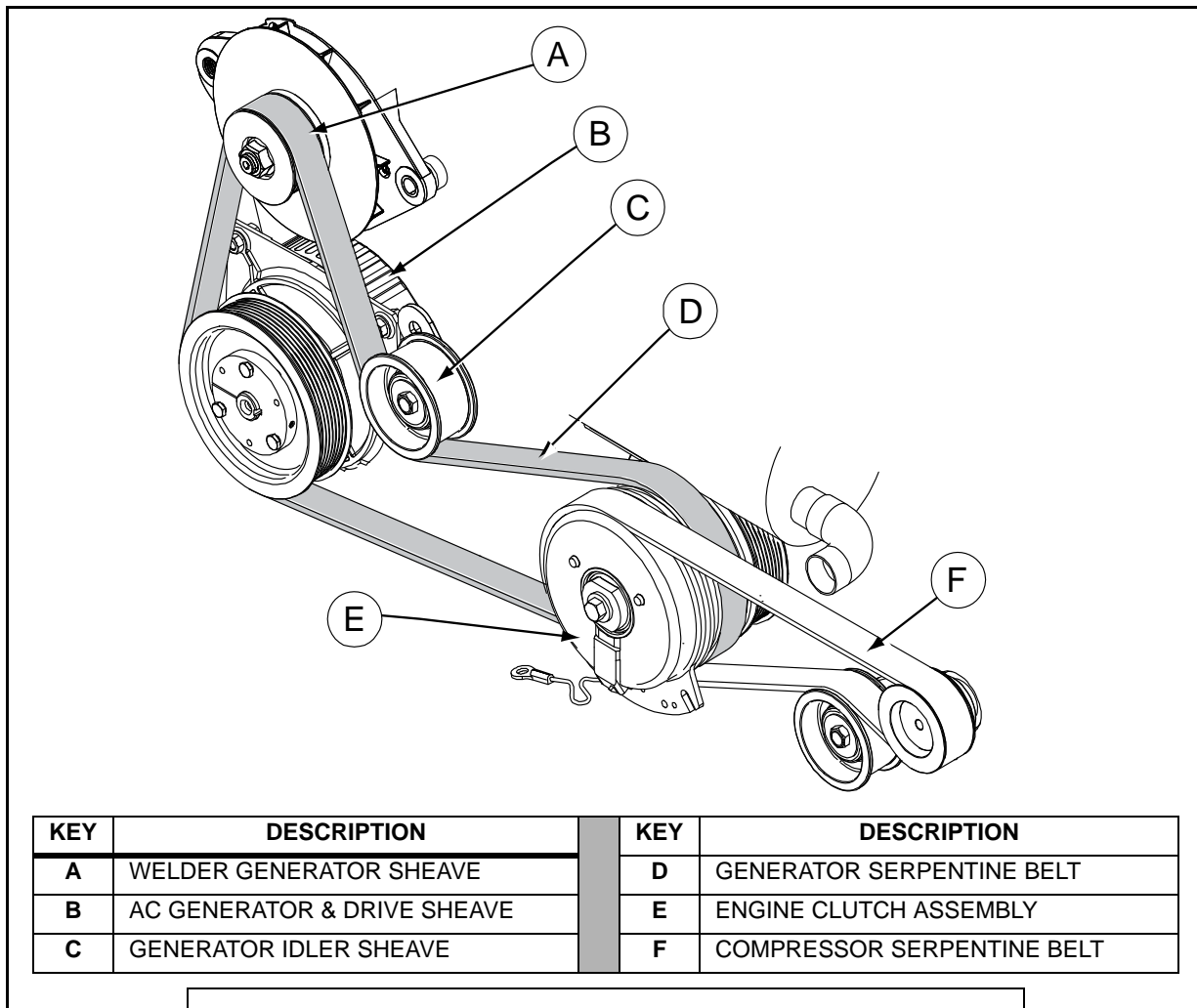

Figure 6-20: Generator Serpentine Belt Positioning

double sheave track on the engine clutch assembly.

- At this point the belt will need to be checked for proper tension. Consult **Section 6.5.16.3** on how to re-tension the generator serpentine belt.



**DANGER**

Fuses will need to be replaced if they are blown when tripped. When changing any fuse, or dealing directly with any function of the electrical system maintenance, always be aware of the safety warnings given in **Section 1, Safety**.

**6.6 SERVICING THE SYSTEM FUSES AND CIRCUIT BREAKERS**

Consult **Figure 6-21** for the location of the DC welder generator fuse, and **Figure 6-22** for the locations of the Power System fuses. Consult **Figure 6-23** to determine the location of the engine fuse locations.



TOOLS NEEDED	REPLACEMENT PART(S) <sup>T</sup>	FIG / KEY#
Fuse Removal Tool (recommended), or Pliers	5 Amp Fuse No. 263532	6-24 / A
	10 Amp Fuse No. 263173	6-24 / E & F 6-25 / A
	15 Amp Fuse No. 265909	6-24 / D
	40 Amp Relay No. 267305 (x 7)	6-24 / G
	30 Amp Fuse No. EL94073	6-25 / B
	40 Amp Auto-Reset Breaker No. 270492	6-25 / C

**NOTE**

Replacement fuses can sometimes be found at local vendor carriers, such as automobile supply stores, hardware stores, etc.

For specific-rated amp fuse locations, consult *Figures 6-21 through 6-23*. For location of 50A relay no. 267305, refer to key no. 35 on *Section 9.7, Instrument Panel*.

## 6.7 EXTREME CONDITION OPERATION

System Component or Part Group Task	Manual Section	Location
<b>Extreme Condition Operation</b>	<b>6.7</b>	<b>page 95</b>
Cold Weather Operation	6.7.1	page 97
Engine Operation	6.7.1.1	page 97
High Temperature Operation	6.7.2	page 97
High Altitude Operation	6.7.3	page 97

**NOTE**

If operating the machine in high humidity, the drain valve can be left partially open to relieve water build-up during operation. This water may contain a small amount of oil.

Auto drain kit is available from Vanair®. Consult *Section A.5*, for order number.

When operating in extreme hot or cold conditions, extra attention should be given to any indications that could lead to a serious problem. Machine review and maintenance check schedules should be more frequent than the normal suggestions given in **Section 6.3, Maintenance Schedule Table**.

Become familiar with the alternative operation procedures given in this section before operating the power system package in any type of extreme ambient conditions.

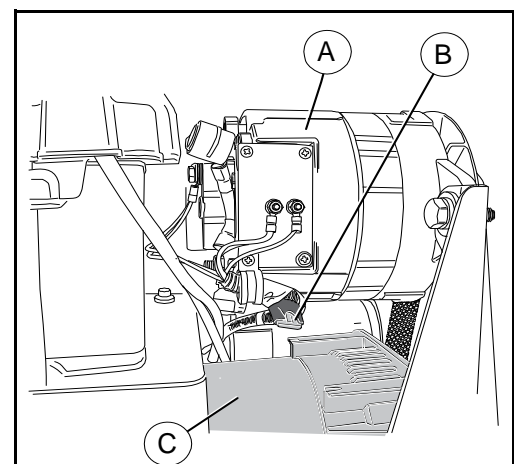

KEY	DESCRIPTION
A	DC WELDER GENERATOR
B	15 AMP FUSE
C	AC GENERATOR

*Figure 6-21: DC Welder Generator Fuse Location*

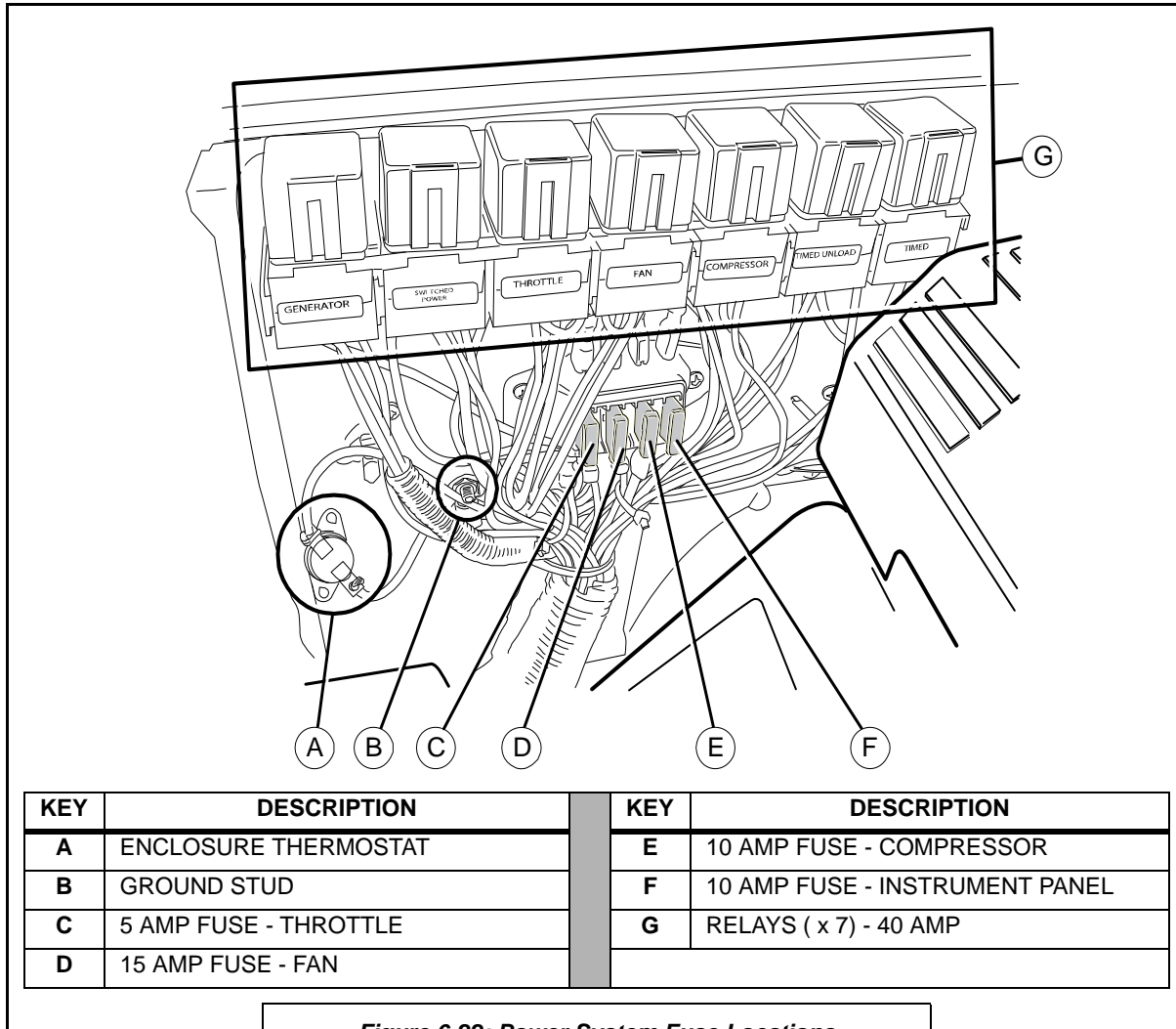

**Figure 6-22: Power System Fuse Locations**

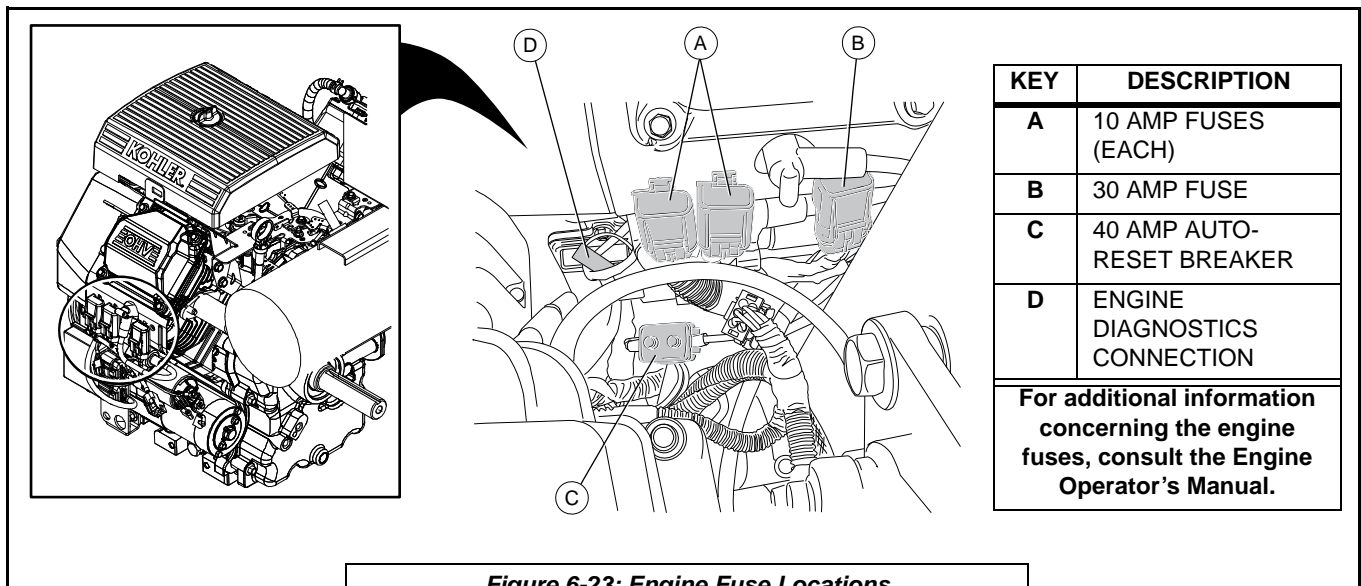

**Figure 6-23: Engine Fuse Locations**

### 6.7.1 COLD WEATHER OPERATION

Additional care should be taken under consideration when operating the package in extreme cold weather environments or ambient temperatures.

Run machine with no load at full speed using the generator switch to warm up the machine.

Heater blanket is available for air inlet solenoid.

#### 6.7.1.1 ENGINE OPERATION

The standard recommendation of 10W-30 engine oil is suitable for temperatures down to -5°F. If temperatures are consistently below 30°F, it is recommended that 5W-30 oil be used. If temperatures are below -25°F, a high-performance, fully synthetic oil, such as AMSOIL 5W-30 should be used which is suitable to temperatures of -55°F.

In below zero temperatures a fuel line deicer product may need to be used.

Check the fuel filter regularly to insure that it contains no water.

Vanguard™ Premium Synthetic Oil is suitable for use from -40°F to 110°F.

Drain the moisture from the tank when it is warm from extended operation.

### 6.7.2 HIGH TEMPERATURE OPERATION

The standard recommendation of 10W-30 engine oil is suitable for operation in temperatures up to 110°F.

Extra care should be taken to keep the engine and air compressor clean and to not restrict the air flow around the unit.

### 6.7.3 HIGH ALTITUDE OPERATION

Engine horsepower will decrease by 3.5% for every 1,000 ft. increase in altitude. At high altitude overall unit performance will deteriorate, and care will need to be taken not to overload the engine by using more than one function of the unit.

#### NOTE



Ethanol blended fuels, such as E85, are prohibited for use with the Kohler 29 EFI engine.

#### NOTE

Refer to the Engine Operator's Manual for detailed maintenance and replacement procedures for the engine.

## 6.8 STORAGE AND INTERMITTENT USE

System Component or Part Group Task	Manual Section	Location
<b>Storage and Intermittent Use</b>	<b>6.8</b>	<b>page 98</b>
Intermittent Use	6.8.1	page 98
Long-term Storage	6.8.2	page 98



### CAUTION

Parts can wear over time. Do not operate with worn equipment; replace as needed.

#### 6.8.1 INTERMITTENT USE

If the unit is not used very regularly always treat the fuel with a fuel stabilizer.

Check all belts and hoses for signs of deterioration such as visible surface cracks, stiffness or discoloration.

#### 6.8.2 LONG TERM STORAGE

Disconnect the battery cable that is connected to the positive (+) side of the battery.

Depressurize the air tank and open the drain valve on the tank.

Cover the unit with a tarp or plastic to prevent the accumulation of dust, but leave the bottom open for air circulation.

Fill gas tank with fuel and fuel stabilizer to prevent moisture build-up in the tank.

# SECTION 7: TROUBLESHOOTING

## 7.1 GENERAL INFORMATION

The information contained in this section has been compiled from years' worth of information gathered from the field. It contains symptoms and usual causes for the most common types of problems that may occur. All available data concerning the trouble should be systematically analyzed before undertaking any repairs or component replacement.

A visual inspection is worth performing for almost all problems and may avoid unnecessary additional damage to the machine. The procedures which can be performed in the least amount of time and with the least amount of removal or disassembly of parts, should be performed first. Adherence to a routine maintenance regimen will minimize the occurrence of many common problems. Refer to **Section 6.3, Maintenance Schedule Table** for a typical maintenance regimen program.

Although Vanair® strives to anticipate situations that may occur during the operation life of the machine package, the **Troubleshooting Guide** may not cover all possible situations. Be aware that additional troubleshooting information may be found in other sources such as the Engine Operator's Manual. Should the situation remain unresolved after exhausting available sources, contact the Vanair Service Department at:

**Phone: 800-526-8817 (toll free)**

**Phone: 219-879-5100**

**Fax: 219-879-5335**

### NOTE

When contacting the Vanair Service Department, please have machine serial number on hand to quickly expedite service. See **Figure 7-1** for machine serial plate location.



### WARNING

**DO NOT** operate any of the Air N Arc 300 Series All-In-One Power System's functions if there is a known unsafe condition. Disable the equipment by disconnecting it from its power source. Install a lock-out tag to identify the equipment as inoperable to other personnel to prevent accidental application.



### WARNING

**Before starting, performing maintenance, or replacing parts, relieve the entire system pressure by opening the air tank drain valve, which will vent all pressure to the atmosphere.**

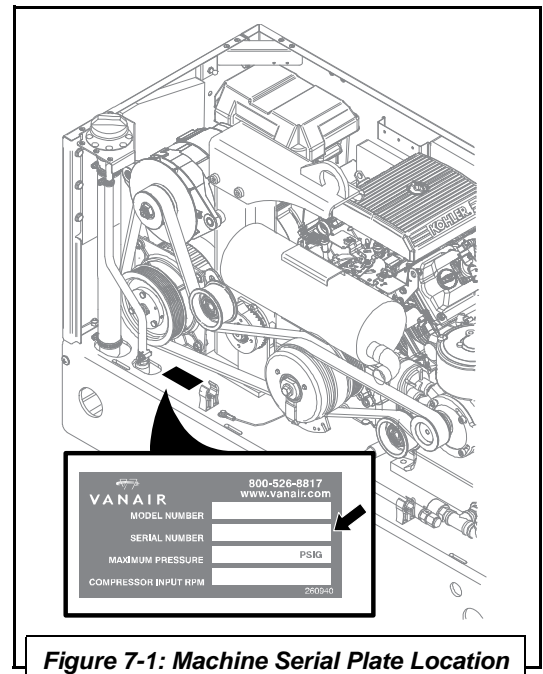

**Figure 7-1: Machine Serial Plate Location**

<b>7.2 TROUBLESHOOTING GUIDE</b>			
<b>Fault/Malfunction</b>	<b>Possible Cause</b>	<b>Corrective Action</b>	
<b>ENGINE</b>			
Engine will not crank	Faulty battery connection.	Check for proper battery connections and battery charge.	
	Battery out of power	Recharge or replace battery.	
	Engine fuse blown or faulty	Check engine fuse: See <b>Section 6.6, Servicing the System Fuses and Circuit Breakers</b> , and/or consult the Engine Operator's Manual.	
	Machine hood shutdown safety switch prevents start-up of engine	Close hood panel or check if roof switch is faulty. See <b>Section 1.11, Machine Canopy Access Safety Switches</b> .	
Engine will crank, but not start	Low fuel and/or oil supply	Check fuel gauge. Check engine oil level; refer to <b>Section 6.5.13, Checking the Engine Oil</b> . Replenish as necessary. Consult the Engine Operator's Manual for additional information on engine maintenance.	
	Pinched fuel line	Replace or reroute if necessary.	
	Plugged fuel filter(s)	Replace if necessary. Refer to <b>Section 2.4, Engine</b> , and the Engine Operator's Manual for additional information on engine maintenance.	
		Low battery voltage	Recharge or replace if necessary.
		Loose connections; tighten connections. Dirty connections; clean connections.	
	Plugged engine air filter	Replace engine air filter. Refer to Engine Operator's Manual.	
	Defective oil pressure switch	Check continuity, and replace if necessary.	
	Blown fuse	Check continuity, and replace if necessary. See <b>Section 6.6, Servicing the System Fuses and Circuit Breakers</b> , and/or consult the Engine Operator's Manual.	
	Poor ground connection	Check and clean/renew connection.	
	Machine belt access panel shutdown safety switch prevents start-up of engine	Close door or check if door switch is faulty. See <b>Section 1.11, Machine Canopy Access Safety Switches</b> .	
<i>Continued on next page</i>			

<b>7.2 TROUBLESHOOTING GUIDE</b>		
<b>Fault/Malfunction</b>	<b>Possible Cause</b>	<b>Corrective Action</b>
<b>ENGINE (CONTINUED)</b>		
Improper Control Operation: Engine does not speed up	Throttle solenoid stuck	Check throttle solenoid. Replace if necessary.
		Check throttle relay; replace if necessary. Refer to <b>Section 6.6, Servicing the System Fuses and Circuit Breakers</b> .
	Governor stuck	Free governor and lubricate if necessary.
	Fuel filter partly plugged	Replace fuel filter. Refer to <b>Section 2.4, Engine</b> , and the Engine Operator's Manual.
Improper Control Operation: Engine does not slow down	Leak in control line	Check for leaks; replace line if necessary.
	Pressure switch out of adjustment	Adjust to proper pressure setting. Refer to <b>Section 2.2.7, Adjustable Pressure Switch</b> , and <b>Section 6.5.15, Adjusting the Pressure Setting</b> . Replace if switch continues to deviate from setting.
	Pressure switch faulty	Replace pressure switch.
	Throttle solenoid stuck	Check throttle solenoid. Replace if necessary.
		Check throttle relay; replace if necessary. Refer to <b>Section 6.6, Servicing the System Fuses and Circuit Breakers</b> .
	Governor stuck	Free governor and lubricate if necessary.
Engine overheats	Located too close to obstruction.	Move further from obstruction.
	Engine oil filter plugged	Replace engine oil filter. Refer to <b>Section 2.4, Engine</b> , and the Engine Operator's Manual.
	Low oil level	Check engine oil level; refer to <b>Section 6.5.13, Checking the Engine Oil</b> . Replenish as necessary. Consult the Engine Operator's Manual for additional information on engine maintenance.
	Restricted cooling air in or out	Clean engine intake grill. Refer to <b>6.5.12</b> .
	Engine oil cooler plugged	Clear debris/dirt from cooler core/flush shroud. Refer to <b>6.5.12</b> .
<i>Continued on next page</i>		

<b>7.2 TROUBLESHOOTING GUIDE</b>		
<b>Fault/Malfunction</b>	<b>Possible Cause</b>	<b>Corrective Action</b>
<b>ENGINE (CONTINUED)</b>		
Engine stops during operation	Low oil level	Check engine oil level; refer to <b>Section 6.5.13, Checking the Engine Oil</b> . Replenish as necessary. Consult the Engine Operator's Manual for additional information on engine maintenance.
	Engine shutdown switch activated	Confirm that access door is properly in place. Replace faulty engine shutdown switch; see <b>Section 1.11, Machine Canopy Access Safety Switches</b> .
	Low fuel	Check fuel gauge. Fill as necessary.
Engine will not throttle up for various functions	Faulty throttle solenoid	Check throttle solenoid; replace if necessary.
		Check throttle relay; replace if necessary. Refer to <b>Section 6.6, Servicing the System Fuses and Circuit Breakers</b> .
Gradual loss of engine power	Contaminated fuel	Draw and replace fuel supply.
	Wrong fuel type fill	Use only gasoline—do not use E85, etc. Refer to Engine Operator's Manual for information on engine fuel type to use.
	Engine air filter contaminated	Check air filter. Replace if necessary (refer to the Engine Operator's Manual).
	Fuel filter(s) contaminated	Check fuel filters. Refer to <b>Section 2.4, Engine</b> , and the Engine Operator's Manual for additional information on engine maintenance.
	vapor lock	Machine overloading. Allow to cool.
Refer to overheating section in this Troubleshooting Guide.		
<b>For additional information concerning an engine problem, consult the Engine Operator's Manual.</b>		
<b>COMPRESSOR</b>		
Compressor overheats This will cause a compressor shutdown and compressor fault light to turn on. Before restarting the compressor, determine the cause for overheating.	Low compressor fluid level	Check oil level and refill to proper level if necessary (ensure machine is parked on a level surface). Refer to <b>Section 6.5.3, Checking the Compressor Oil</b> .
<b>Continued on next page</b>		



<b>7.2 TROUBLESHOOTING GUIDE</b>		
<b>Fault/Malfunction</b>	<b>Possible Cause</b>	<b>Corrective Action</b>
<b>COMPRESSOR (CONTINUED)</b>		
Compressor overheats  This will cause a compressor shutdown and compressor fault light to turn on. Before restarting the compressor, determine the cause for overheating (continued)	Defective switch	Replace switch.
	Obstructed fluid cooler	Clear debris/dirt from cooler core/flush shroud.
	Obstructed cooler fins	Clear/clean if required. Refer to <b>Section 6.5.12</b> .
	Insufficient air flow over cooler	Check for obstructions (frame, body, etc.) to cooling air flow.
	Compressor oil filter plugged	Replace filter; refer to <b>Section 6.5.4, Replacing the Compressor Oil Filter Element</b> .
	Input rpm too high	Adjust to proper setting; refer to <b>Section 6.5.14, Adjusting the Engine Speed</b> , and the Engine Operator's Manual.
	Fan not operating	Check fan fuse for continuity, and replace if necessary. See <b>Section 6.6, Servicing the System Fuses and Circuit Breakers</b> .  Check fan switch for continuity. Replace if necessary.  Check fan motor.  Check fan relay for continuity. Replace if necessary.  Check all electrical connections and lines; clean/renew connections where needed.
Compressor shuts down with air demand present	Compressor temperature switch	Check for loose wire; verify wire connections.
		Faulty temperature switch. Replace switch.
	Restricted cooling air intake	Reposition machine.
	Fan not operating	Check fan fuse for continuity, and replace if necessary. See <b>Section 6.6, Servicing the System Fuses and Circuit Breakers</b> .
Check fan switch for continuity. Replace if necessary.		
Check fan relay for continuity. Replace if necessary.		

*Continued on next page*

<b>7.2 TROUBLESHOOTING GUIDE</b>		
<b>Fault/Malfunction</b>	<b>Possible Cause</b>	<b>Corrective Action</b>
<b>COMPRESSOR (CONTINUED)</b>		
Compressor shuts down with air demand present (continued)	Fan not operating (continued)	Check all electrical connections and lines; clean/renew connections where needed.
	Compressor oil filter plugged	Replace filter; refer to <b>Section 6.5.4, Replacing the Compressor Oil Filter Element.</b>
	Soiled cooler core	Clean cooler core.
	Internally contaminated cooler core	Consult the Vanair Service Department for assistance in cleaning/flushing the cooler core.
	Defective engine oil pressure switch	Replace engine oil pressure switch. Refer to the Engine Operator's Manual.
Compressor will not build up pressure	Compressor system is not receiving enough operating power	If running more than one function simultaneously, turn off competing function.
	Air demand too high	Check for leaks and take corrective action.
		Check air tools for wear, damage, or malfunctions. Replace or repair.
	Compressor capacity too low to accommodate demand	Substitute larger capacity compressor system.
	Compressor air filter plugged	Check air filter. Replace if necessary; refer to <b>Section 6.5.1, Compressor Air Filter.</b>
	Pressure switch out of adjustment	Reset pressure switch. Refer to <b>Section 2.2.7, Adjustable Pressure Switch</b> , and <b>Section 6.5.15, Adjusting the Pressure Setting.</b> Replace if switch continues to deviate from setting.
	Belt(s) slipping	Re-situate and adjust belt tension, or replace belt if necessary. Consult <b>Section 6.5.16, Replacing and Re-tensioning the Serpentine Belts</b>
	Defective pressure switch	Replace pressure switch.
	Engine governor stuck	Free governor and lubricate if necessary. Consult the Engine Operator's Manual.
Faulty throttle solenoid	Check throttle solenoid; replace if necessary.	
	Check throttle relay; replace if necessary. Refer to <b>Section 6.6, Servicing the System Fuses and Circuit Breakers.</b>	
<i>Continued on next page</i>		

7.2 TROUBLESHOOTING GUIDE		
Fault/Malfunction	Possible Cause	Corrective Action
COMPRESSOR (CONTINUED)		
<p>Compressor system over-pressures</p> <p>This condition will cause a compressor shutdown, and a fault light will turn on. Before restarting the compressor, determine the cause of the over-pressure.</p>	Pressure switch setting too high	Reset pressure switch. Refer to <b>Section 2.2.7, Adjustable Pressure Switch</b> , and <b>Section 6.5.15, Adjusting the Pressure Setting</b> . Replace if switch continues to deviate from setting.
	Pressure switch malfunction	Check for operation/damage: repair or replace.
	Unload solenoid valve defective	Rebuild or replace solenoid valve. Refer to <b>Section 6.5.8</b> .
	Leak in air control line	Check for leaks and take corrective action.
	Damaged/kinked control line	Check line for damage (wear, kinks, etc.). Re-route, re-tie or replace if necessary (refer to <b>Appendix A.6, Hose Installation Guide</b> for assistance in running or checking hose lines).
	Restriction in control line	Clean if soiled; if ice is present, clear and remove.
	Control line connections are not properly seated/poor connection quality	Check lines for proper seating/ensure line ends have been cut cleanly and are square ( <b>DO NOT</b> use wire cutters: use a loom cutting tool or a clean, sharp razor blade).
	Inlet valve Teflon “O” ring popped out of groove	Replace “O” ring: Refer to <b>Section 6.5.2, Repairing the Air Inlet Valve</b> . Order inlet valve repair kit—see <b>Table 9A: Recommended Spare Parts List</b> .
	Inlet valve piston is stuck in down position.	Check for proper operation with an auxiliary air source—replace or rebuild inlet valve. Consult <b>Section 6.5.8</b> .
	Compressor shaft seal is leaking	Replace shaft seal with available kit. Refer to <b>Section 6.5.7</b> .
	Minimum pressure/check valve is malfunctioning	Rebuild or replace check valve: Refer to <b>Section 6.5.11</b> ; order check valve repair kit—see <b>Table 9A: Recommended Spare Parts List</b> .
	Pressure gauge is malfunctioning	Check for proper operation with an auxiliary air source. Replace if necessary.
Check pressure gauge function/control line routing: adjust, repair or replace as necessary.		
<i>Continued on next page</i>		

<b>7.2 TROUBLESHOOTING GUIDE</b>		
<b>Fault/Malfunction</b>	<b>Possible Cause</b>	<b>Corrective Action</b>
<b>COMPRESSOR (CONTINUED)</b>		
Compressor system over-pressures (continued) This condition will cause a compressor shutdown, and a fault light will turn on. Before restarting the compressor, determine the cause of the over-pressure.	Defective safety valve	Replace safety valve.
	Plugged coalescer	Replace coalescer. Refer to <b>Section 6.5.6, Replacing the Spin-on Air/Oil Coalescer.</b>
	Pressure switch setting too high, or switch is malfunctioning	Adjust pressure switch setting. Refer to <b>Section 2.2.7, Adjustable Pressure Switch</b> , and <b>Section 6.5.15, Adjusting the Pressure Setting.</b> Replace if switch continues to deviate from setting.
No service air output	If equipped, OSHA valve/velocity fuse, not functioning properly	Reset or replace OSHA valve.
	Clutch malfunctioning	Check clutch. Replace if necessary.
	Wiring	Check wiring: Loose—secure ; faulty—replace.
	Fuses and/or relays	Check fuses and relays for continuity. Replace if necessary.
	Belt(s)	Belt(s) out of position or malfunctioning. Consult <b>Section 6.5.16</b> , and its sub-sections.
Low service air output	Clogged compressor air filter	Check air filter. Replace if necessary; refer to <b>Section 6.5.1, Compressor Air Filter.</b>
	Solenoid valve sending continuous signal to inlet valve	Rebuild or replace solenoid valve if defective. Refer to <b>Section 6.5.8.</b>
	Incorrect compressor speed	Adjust speed. Refer to <b>Section 6.5.14.</b>
Compressor stalls	Pressure switch setting too high	Adjust pressure switch setting. Refer to <b>Section 2.2.7, Adjustable Pressure Switch</b> , and <b>Section 6.5.15, Adjusting the Pressure Setting.</b> Replace if switch continues to deviate from setting.
	Speed is set too low	Check to see if compressor goes to high speed.
System operating pressure below specified minimum	Air demand too high	Check air tools for wear, damage, or malfunctions. Replace or repair.
	Compressor capacity too low to accommodate demand	Substitute larger capacity compressor system.
<i>Continued on next page</i>		

7.2 TROUBLESHOOTING GUIDE		
Fault/Malfunction	Possible Cause	Corrective Action
COMPRESSOR (CONTINUED)		
System operating pressure below specified minimum (continued)	System leaks or is damaged	Inspect for leaks. Repair and/or replace damaged parts as necessary. Use <b>Section 9, Illustrated Parts List</b> to visually confirm/identify any part that needs to be replaced before ordering part.
	Pressure switch set too low/malfunction	Adjust pressure switch setting. Refer to <b>Section 2.2.7, Adjustable Pressure Switch</b> , and <b>Section 6.5.15, Adjusting the Pressure Setting</b> . Replace if switch continues to deviate from setting.
	Input rpm too low	Adjust to proper setting.
	Inlet valve Teflon "O" ring popped out of groove	Replace "O" ring: Refer to <b>Section 6.5.2, Repairing the Air Inlet Valve</b> . Order inlet valve repair kit—see <b>Table 9A: Recommended Spare Parts List</b> .
	Inlet valve piston stuck in down position.	Check for proper operation with an auxiliary air source—replace or rebuild inlet valve.
	Leaking compressor shaft seal	Replace shaft seal with available kit. Refer to <b>Section 6.5.7, Repairing the Compressor Shaft Seal</b> . Order shaft seal kit—see <b>Table 9A: Recommended Spare Parts List</b> .
	Soiled inlet valve	Remove valve and clean piston. Refer to <b>Section 6.5.2, Repairing the Air Inlet Valve</b> . Order inlet valve repair kit—see <b>Table 9A: Recommended Spare Parts List</b> .
	Inlet valve fails to open	Repair/replace inlet valve. Refer to <b>Section 6.5.2, Repairing the Air Inlet Valve</b> . Order inlet valve repair kit—see <b>Table 9A: Recommended Spare Parts List</b> .
	Inlet valve frozen	Repair/replace inlet valve. Refer to <b>Section 6.5.2, Repairing the Air Inlet Valve</b> . Order inlet valve repair kit—see <b>Table 9A: Recommended Spare Parts List</b> .
Excess amount of oil in air discharge	Machine not on level surface	Move machine to level surface.
<i>Continued on next page</i>		

7.2 TROUBLESHOOTING GUIDE		
Fault/Malfunction	Possible Cause	Corrective Action
COMPRESSOR (CONTINUED)		
Excess amount of oil in air discharge (continued)	Compressor oil level too high	The correct oil level is the half-way mark on the dipstick with the compressor shut down, and the machine on a level surface. Drain excess oil to correct level.
		Tank not positioned with the drain at its lowest point. Reposition machine. <b>NOTE:</b> machine must be operated while on a level surface in order for proper compressor oil circulation throughout the system.
	Coalescer element plugged or damaged	Replace the coalescer element. Consult <b>Section 6.5.6, Replacing the Spin-on Air/Oil Coalescer</b> . Order replacement coalescer element—see <b>Table 9A: Recommended Spare Parts List</b> .
Excessive moisture in the compressed air	Moisture accumulating in air tank	Drain water from air tank. Refer to <b>Section 6.5.9, Draining the Air Tank</b> .
Compressor system fails to build-up pressure	Service valve is open	Close service valve.
	Pressure gauge is malfunctioning	Check pressure gauge function/control line routing: adjust, repair or replace as necessary.
		Check for proper operation with an auxiliary air source. Replace if necessary.
	Inlet valve Teflon “O” ring popped out of groove	Replace “O” ring: Refer to <b>Section 6.5.2, Repairing the Air Inlet Valve</b> . Order inlet valve repair kit—see <b>Table 9A: Recommended Spare Parts List</b> .
	Inlet valve piston stuck in down position.	Check for proper operation with an auxiliary air source—replace or rebuild inlet valve.
	Discharge piping leaks	Tighten connections; replace faulty piping.
Leaking compressor shaft seal	Replace shaft seal with available kit. Refer to <b>Section 6.5.7, Repairing the Compressor Shaft Seal</b> . Order shaft seal kit—see <b>Table 9A: Recommended Spare Parts List</b> .	
	Soiled inlet valve	Remove valve and clean piston. Refer to <b>Section 6.5.2, Repairing the Air Inlet Valve</b> . Order inlet valve repair kit—see <b>Table 9A: Recommended Spare Parts List</b> .
<i>Continued on next page</i>		

<b>7.2 TROUBLESHOOTING GUIDE</b>		
<b>Fault/Malfunction</b>	<b>Possible Cause</b>	<b>Corrective Action</b>
<b>COMPRESSOR (CONTINUED)</b>		
Compressor system fails to build-up pressure (continued)	Inlet valve fails to open	Repair/replace inlet valve. Refer to <b>Section 6.5.2, Repairing the Air Inlet Valve</b> . Order inlet valve repair kit—see <b>Table 9A: Recommended Spare Parts List</b> .
	Inlet valve frozen	Repair/replace inlet valve. Refer to <b>Section 6.5.2, Repairing the Air Inlet Valve</b> . Order inlet valve repair kit—see <b>Table 9A: Recommended Spare Parts List</b> .
Compressor relief valve opening	Safety switches not operating (these should shut down the compressor before the relief valve opens)	Check pressure safety switch/control box. Replace if necessary.
<b>WELDER</b>		
Welder and/or battery charger behave erratically	Connection cables or receptacles are soiled/contaminated	Check for twisted cables and/or soiled/contaminated or loose receptacle connections.  Untwist and/or straighten out any suspected cable tensions. Carefully wipe off any contaminants to receptacle connectors before re-connecting. Replace any worn or damaged cables or receptacles. Contact Vanair® Mfg., Inc. Service Department if behavior persists.
	Welding function is not drawing enough operating power	If running more than one function simultaneously, turn off competing function.
No welder output	Fuse at welder field blown	Replace the welder field fuse. Refer to <b>Section 6.6, Servicing the System Fuses and Circuit Breakers</b>
Display not working	Loose or faulty wiring	Check wiring: Loose—secure ; faulty—replace.
Lights do not turn off	Battery charge low	Flip AC generator switch to bring engine to high rpm, and charge battery.
<b>AC GENERATOR</b>		
No AC generator output	Serpentine belt out of position or malfunctioning	Re-situate and adjust belt tension, or replace belt if necessary. Consult <b>Section 6.5.16, Replacing and Re-tensioning the Serpentine Belts</b> . Order replacement belt—see <b>Table 9A: Recommended Spare Parts List</b> .
<i>Continued on next page</i>		

<b>7.2 TROUBLESHOOTING GUIDE</b>		
<b>Fault/Malfunction</b>	<b>Possible Cause</b>	<b>Corrective Action</b>
<b>AC GENERATOR</b>		
No AC generator output (continued)	Loose or faulty wiring	Check wiring: Loose—secure ; faulty—replace.
	Circuit breaker blown	Replace the circuit breaker. Refer to <b>Section 6.6, Servicing the System Fuses and Circuit Breakers</b>
Low AC voltage	Engine speed too low for demand	Adjust speed control. Consult <b>Section 6.5.14, Adjusting the Engine Speed</b> , and the Engine Operator's Manual.
High AC voltage	Engine speed too high for demand	Adjust speed control. Consult <b>Section 6.5.14, Adjusting the Engine Speed</b> , and the Engine Operator's Manual.



# SECTION 8: DIAGRAMS

---

## 8.1 GENERAL INFORMATION

The diagrams located in this section of the manual are designed to assist the service technician with troubleshooting any problems that may arise while operating the All-In-One Power System within its intended use.

The flow schematic and wiring diagram should be used together when identifying any potential problems. They are laid out in a format that is designed to be easy to read for the end user or a service technician.

NOTE
For machine measurement specifications refer to <i>Section 4.5, Installation and Dimensions Diagram</i> (parts 1 and 2).

# 8.2 WIRING DIAGRAM - AIR N ARC 300 SERIES

SYSTEM		WIRING INFORMATION	
#	DESCRIPTION	WIRE #	DESCRIPTION
1	ENGINE	1	GROUND
2	12V: CONSTANT	2	12V: CONSTANT
3	12V: SWITCHED INT. PNL	3	12V: SWITCHED MACHINE
4	12V: SWITCHED MACHINE	4	12V: SWITCHED MACHINE
5	12V: START	5	12V: START
6	ENGINE KILL	6	ENGINE KILL
7	MIL	7	MIL
8	FUEL SENDER	8	FUEL SENDER
9	THROTTLE TO RELAY	9	THROTTLE TO RELAY
10	THROTTLE FROM RELAY	10	THROTTLE FROM RELAY
11	WELDER	11	FIELD
12	CABLE	12	CABLE
13	HALL EFFECT	13	HALL EFFECT
14	HALL EFFECT	14	HALL EFFECT
15	SHUT DOWN	15	SHUT DOWN
16	COMPRESSOR	16	COMPRESSOR
17	FAULT LIGHT	17	FAULT LIGHT
18	TEMP (FAN)	18	TEMP (FAN)
19	FAN	19	FAN
20	HEATER	20	HEATER
21	COMPRESSOR	21	COMPRESSOR UNLOAD
22	COMPRESSOR UNLOAD	22	COMPRESSOR UNLOAD
23	CAPACITOR	23	CAPACITOR
24	CAPACITOR	24	CAPACITOR
25	GENERATOR	25	GENERATOR

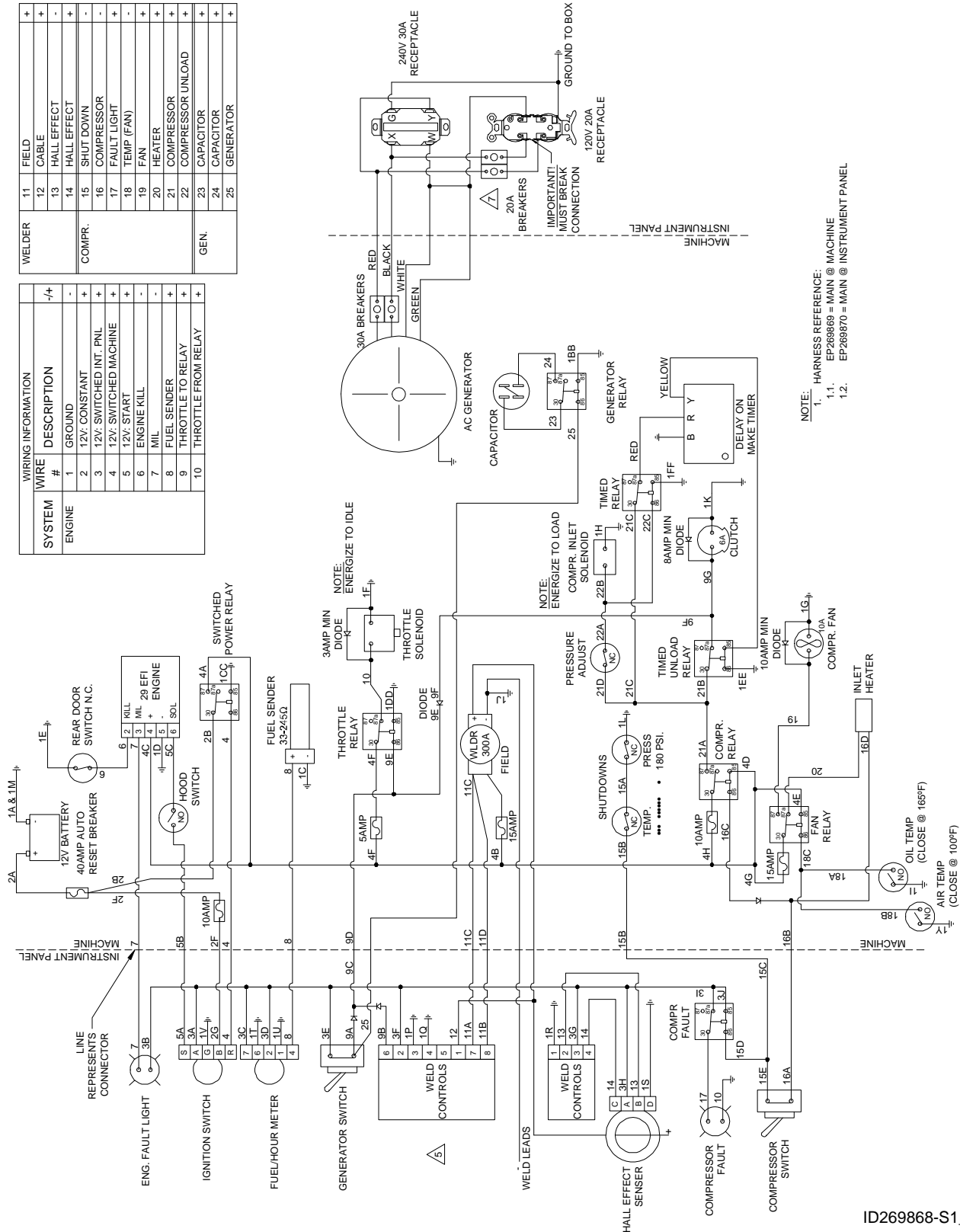

### 8.3 WIRING DIAGRAM - SWITCHES & LIGHTS

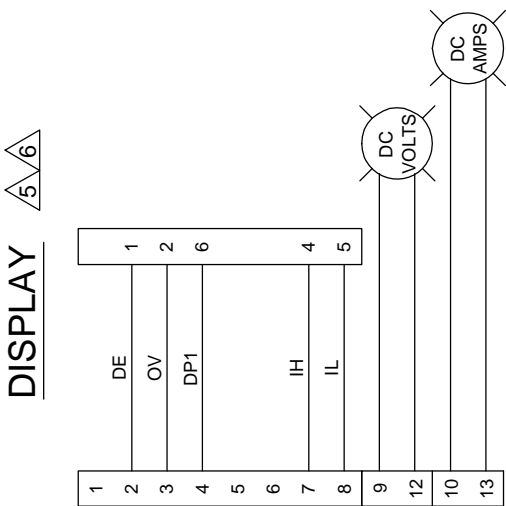

**NOTE:**

1. HARNESS REFERENCE:
  - 1.1. EP269871 = INSTRUMENT PANEL LIGHTS.
  - 1.2. EP269872 = INSTRUMENT PANEL SWITCHES.
  - 1.3. EP270315 = INSTRUMENT PANEL DISPLAY.

6

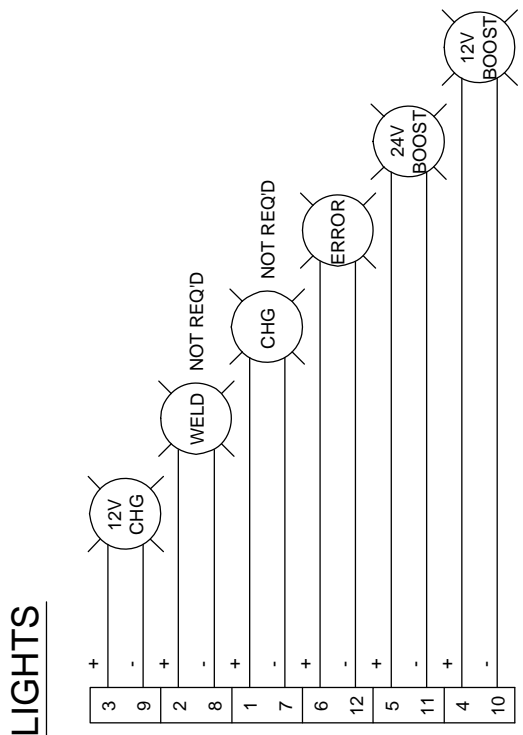
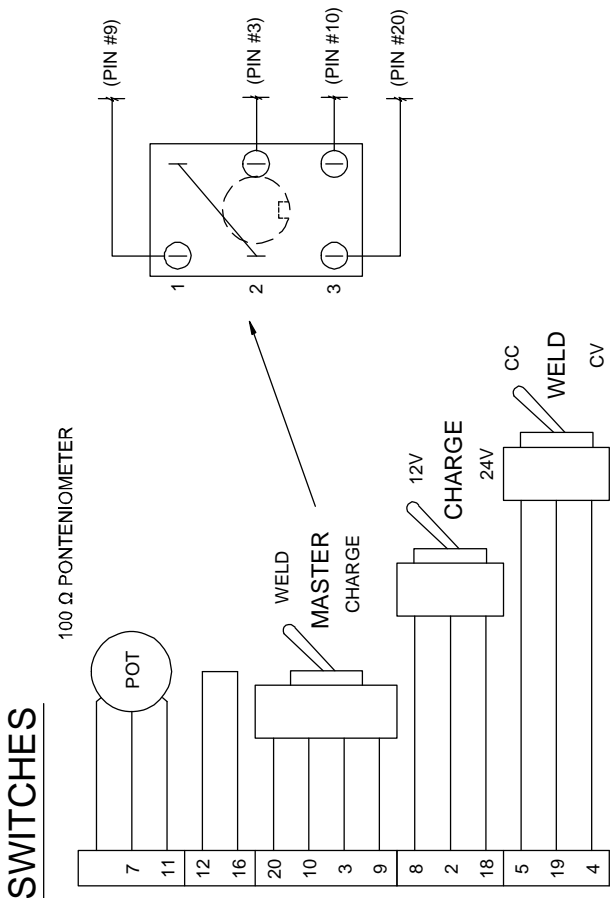

ID269868-S2\_r6

# 8.4 TRUNK LINE ASSEMBLY HARNESS

PARTS LIST	
ITEM #	DESCRIPTION
1	WELD CABLE TRUNK LINE
2	DC CONTROL TRUNK LINE
3	AC CORD TRUNK LINE
4	HOSE ASSEMBLY TRUNK LINE
5	SLEEVING, EXPANDABLE, Ø2 X "B"-DIM LG.
6	HEAT SHRINK, BLACK Ø3" X 8" LG.



PART #	ITEM #1	ITEM #2	ITEM #3	ITEM #4	DIM "A"	DIM "B"
MA269937-24	EP269979-24	EP269978-24	EP270470-24	EP73450-24	288" [24'-0"]	270" [22'-6"]
MA269937-22	EP269979-22	EP269978-22	EP270470-22	EP73450-22	264" [22'-0"]	246" [20'-6"]
MA269937-20	EP269979-20	EP269978-20	EP270470-20	EP73450-20	240" [20'-0"]	270" [22'-6"]
MA269937-18	EP269979-18	EP269978-18	EP270470-18	EP73450-18	216" [18'-0"]	198" [16'-6"]
MA269937-16	EP269979-16	EP269978-16	EP270470-16	EP73450-16	192" [16'-0"]	174" [14'-6"]
MA269937-14	EP269979-14	EP269978-14	EP270470-14	EP73450-14	168" [14'-0"]	150" [12'-6"]
MA269937-12	EP269979-12	EP269978-12	EP270470-12	EP73450-12	144" [12'-0"]	126" [10'-6"]
MA269937-10	EP269979-10	EP269978-10	EP270470-10	EP73450-10	120" [10'-0"]	102" [8'-6"]
MA269937-8	EP269979-8	EP269978-8	EP270470-8	EP73450-8	96" [8'-0"]	78" [6'-6"]
MA269937-6	EP269979-6	EP269978-6	EP270470-6	EP73450-6	72" [6'-0"]	54" [4'-6"]

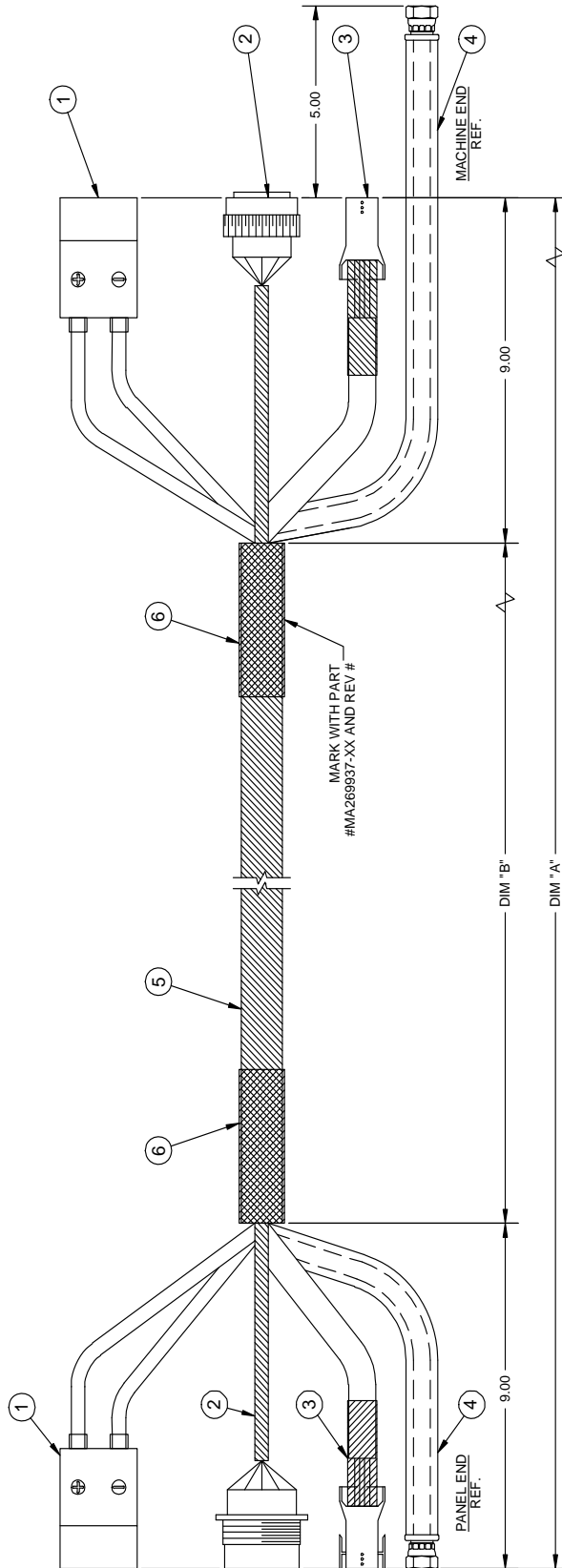

MA269937-XX\_r1

### 8.5 COMPRESSOR FLOW SCHEMATIC DIAGRAM

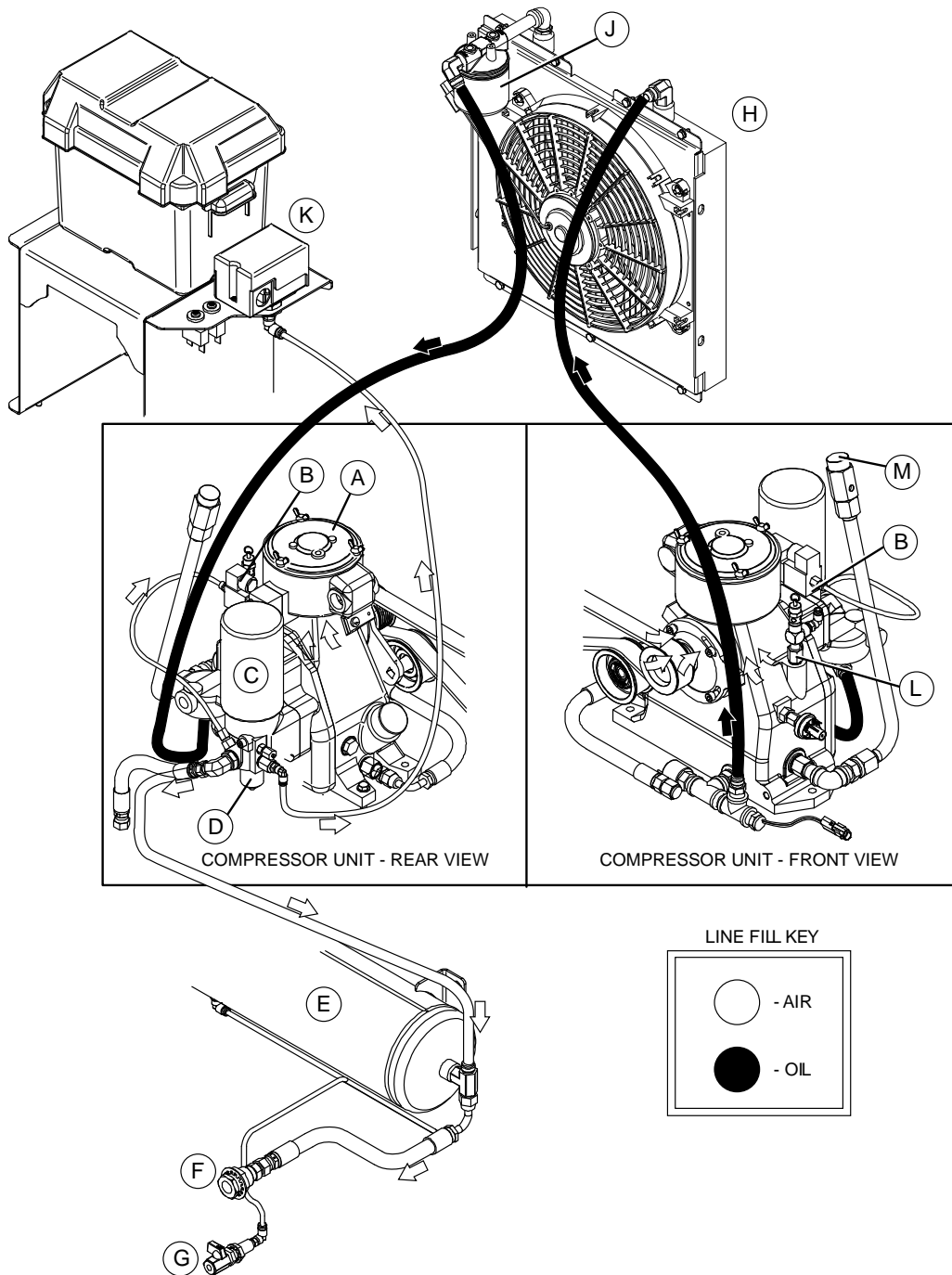

KEY	DESCRIPTION	KEY	DESCRIPTION
A	AIR FILTER	G	AIR TANK MOISTURE DRAIN
B	AIR INLET SOLENOID VALVE	H	OIL COOLER FAN ASSEMBLY
C	AIR/OIL COALESCER SEPARATOR	J	COMPRESSOR OIL FILTER
D	MINIMUM PRESSURE/CHECK VALVE	K	PRESSURE SWITCH
E	AIR TANK	L	RELIEF VALVE
F	'AIR OUT' RECEPTACLE	M	COMPRESSOR OIL FILL PORT

**BLANK PAGE**

# SECTION 9: ILLUSTRATED PARTS LIST

## 9.1 PARTS ORDERING PROCEDURE

Part orders should be placed through the distributor from whom the unit was purchased. If, for any reason parts cannot be obtained in this manner, contact the factory directly at the address or phone numbers below.

When ordering parts, always indicate the **Serial Number** of the machine package. This can be obtained from the Bill of Lading for the machine package, or from the compressor unit serial number plate. See **Figure 9-1** for location of machine package serial plate. Consult **Table 9A: Recommended Spare Parts List** on the next page for a listing of replacement parts.

VANAIR® MANUFACTURING, INC.

10896 West 300 N.

Michigan City, IN 46360

Telephone: (800) 526-8817

(219) 879-5100

Service Fax: (219) 879-5335

Parts Fax: (219) 879-5340

Sales Fax: (219) 879-5800

www.vanair.com

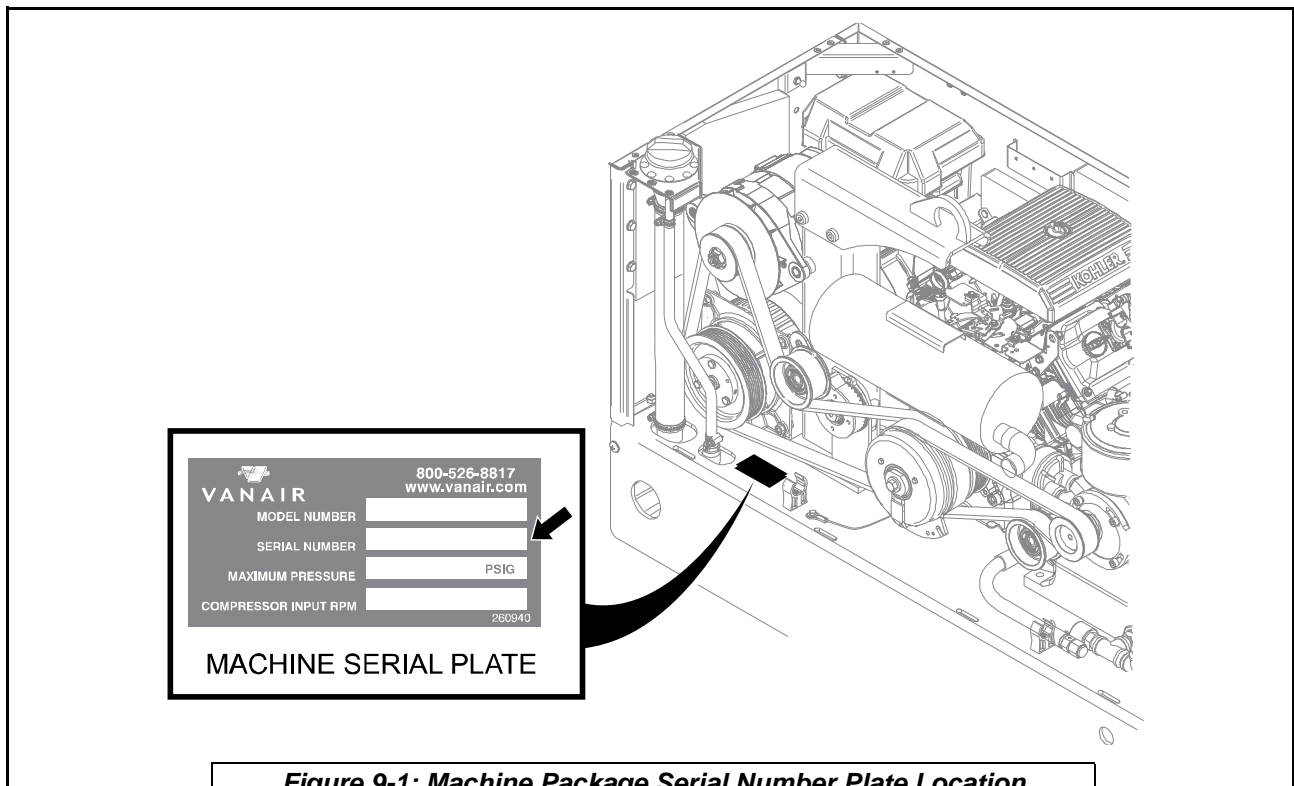

Figure 9-1: Machine Package Serial Number Plate Location

TABLE 9A: RECOMMENDED SPARE PARTS LIST					
KEY NO.	PART NUMBER	DESCRIPTION	QTY	IDENTIFICATION REFERENCE	
				SECTION	KEY NO.
<b>ROUTINE/SCHEDULED MAINTENANCE ITEMS</b>					
1	264626-1/2GAL	Vanguard™ Premium Oil, ½ Gallon <sup>†</sup>	1	-	-
2	266801	Element, Fluid Filter	1	9.4	#4
3	264154-095	Element, Compressor Air Filter	1	Fig 6-1	B
4	264154-109	Element, Air/Fluid Separator Spin-on Style Coalescer	1	Fig 6-7	
5	Consult Factory	Element, Engine Air Filter	1	II	
6	Consult Factory	Filter, Engine	1	II	
7	EN269654	Filter, In-line Fuel (10 micron)	1	Fig 2-1	GG
8	RC81465	Filter, In-line Fuel (70 micron)	1	9.11	#18
<b>NON-ROUTINE MAINTENANCE ITEMS</b>					
9	260230	Switch, Electra-Temp	1	9.3	#1
10	EL270040	Switch, Temperature 100°F Thermostat	1		
11	263744	Fan & Motor Assy. 60-85 CFM	1	9.4	#1
12	CO89649	Gauge, Air, Dry	1	9.7	#29
13	PR81817	Boot, Breaker Panel Mount	1	9.7	#47
14	263532	Fuse, 5 Amp	1	Fig 6-22	C
15	263173	Fuse, 10 Amp	1	Fig 6-22	E
16	265909	Fuse, 15 Amp	1	Fig 6-22	D
17	EL94073	Fuse, 30 Amp	1	Fig 6-23	B
18	270492	Fuse, 40 Amp Auto-Reset Breaker	1	Fig 6-23	C
19	CO276748	Gauge, Hour Meter	1	9.7	#22
20	267305	Relay, 50 Amp (control panel)	1	9.7	#35
21	270501	Relay, 40 Amp (main harness)	7	Fig 6-22	G
22	264325	Switch, 240 Deg F NC	1	9.3	#11
23	CO270157	Breaker, Circuit 240V/25A	2	9.7	#24
24	CO71774	Breaker, Circuit 30A	2	9.10	#7
25	DR270054	Belt, Serpentine Compressor	1	9.3	#38
26	DR98202	Belt, Serpentine Generator	1	9.8	#26
27	264154-112	Kit, Compressor Shaft Seal Rebuild	1	Fig 6-8	
28	264154-106	Kit, Minimum Pressure / Check Valve Rebuild	1	Fig 6-12	
29	264154-102	Kit, Air Inlet Valve Rebuild	1	Fig 6-9	

<sup>†</sup>Use only Vanair® Vanguard™ Premium Synthetic Oil and Genuine Vanair Parts. Inspect and replace damaged components before operation. Substituting non-Vanguard™ Oil or non-genuine Vanair filter components WILL VOID THE COMPRESSOR WARRANTY!

<sup>II</sup> Consult the Engine Operator's Manual.

### NOTE

For a complete list of available options, see Appendix A, Section A.5 Air N Arc 300 Series All-In-One Power System Available Options List

### NOTE

If additional spare parts are being stored for future use, make certain that they are stored in proper containers that allow for protection against contamination, and kept in a clean area of moderate temperature reading. For information on storing the machine package for periods of non-use, consult Section 6.8.2, Long Term Storage.



# NOTES

# 9.2 AIR N ARC 300 SYSTEMS ASSEMBLIES

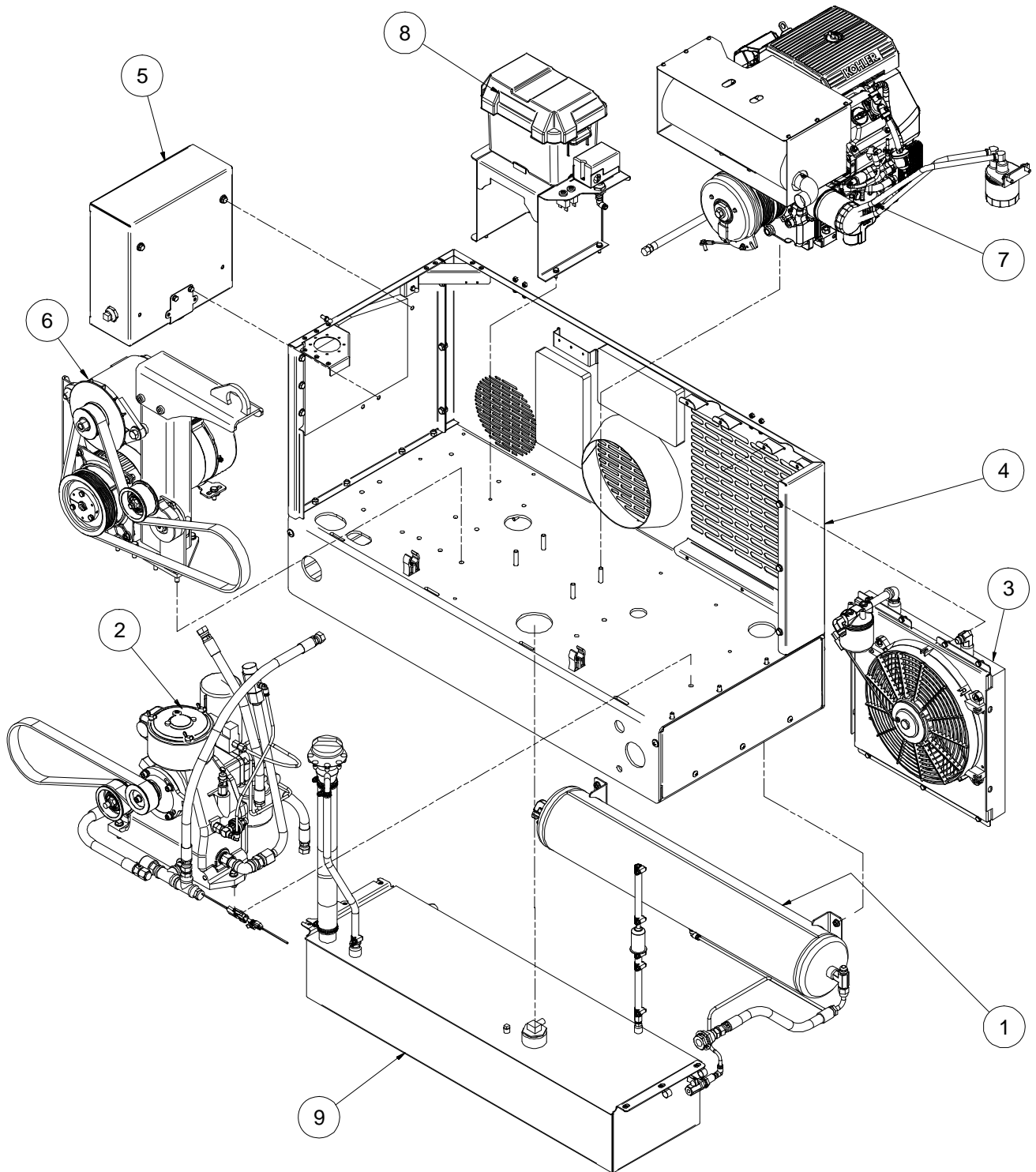

6130008ID\_r0

## 9.2 AIR N ARC 300 SYSTEMS ASSEMBLIES

ITEM	DESCRIPTION	PART NUMBER	QTY
1	AIR STORAGE ASSEMBLY	PA6000027ID	1
2	ID, COMPRESSOR & PARTS ASSY	PA6010015ID	1
3	ID, COOLING SYSTEM	PA6020017ID	1
4	ID, FRAME & CANOPY	PA6030007ID	1
5	INSTRUMENT PANEL	PA6040010ID	1
6	ID, GENERATORS AND PARTS	PA6050004ID	1
7	ID, ENGINE AND DRIVE PARTS	PA6100007ID	1
8	ID, ELECTRICAL SYSTEM	PA6120040ID	1
9	ID, FUEL TANK ASSY	PA6140004ID	1

# 9.3 COMPRESSOR AND PARTS ASSEMBLY

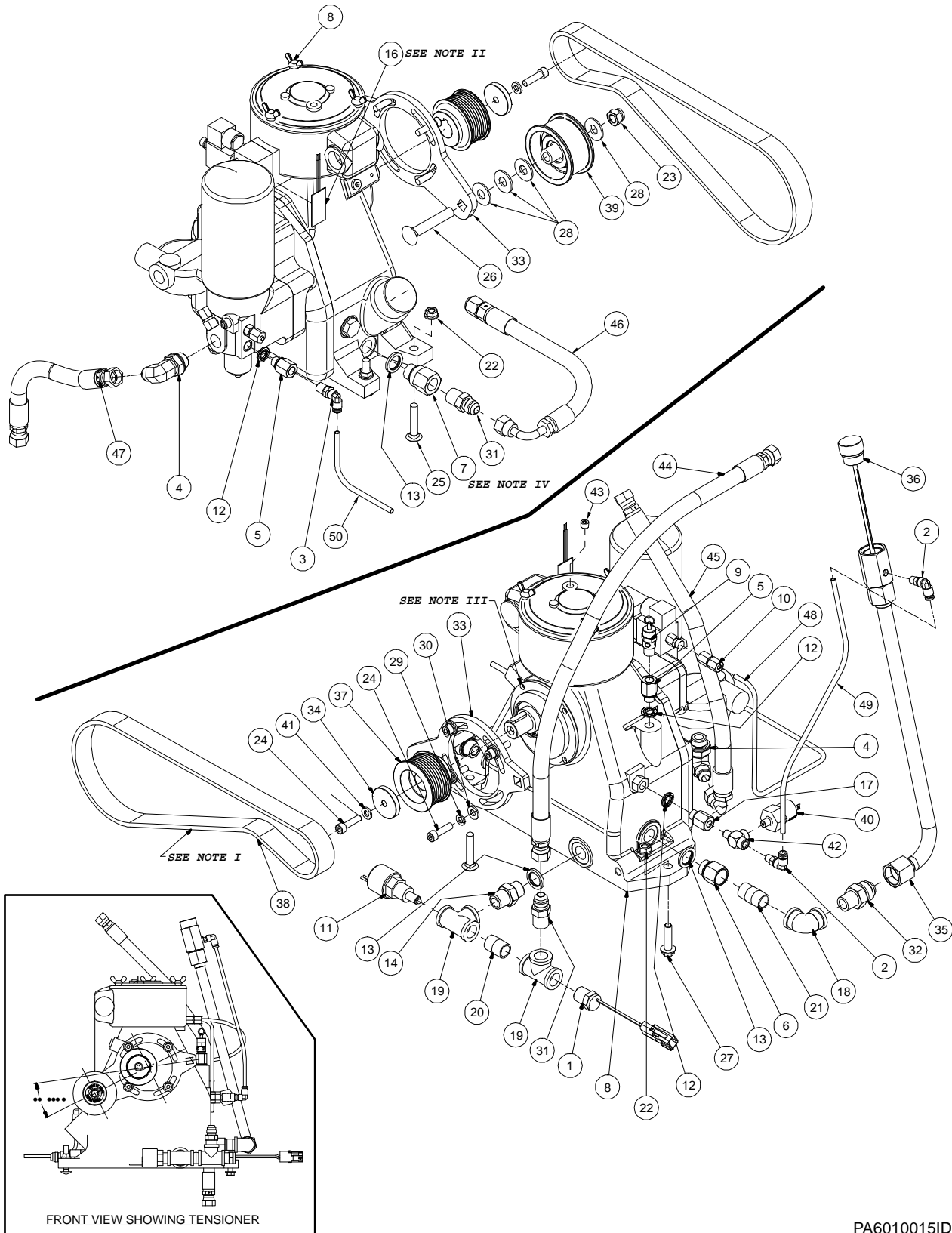

PA6010015ID\_r1

## 9.3 COMPRESSOR AND PARTS ASSEMBLY

ITEM	DESCRIPTION	PART NUMBER	QTY
1	SWITCH , TEMPERATURE (ELECTRIC)	260230	1
2	ELBOW, 1/4T x 1/8P PUSH-ON	261309	2
3	ELBOW, 90 deg. PUSH ON 1/4T x 1/4P	261310	1
4	ELBOW,90 DEG. MJIC x MBSPP 1/2	263747-006	2
5	ADAPTER,FEMALE PIPE x BSPP 1/4	263748-004	2
6	ADAPTER, FEMALE PIPE x BSPP 1/2	263748-012	1
7	ADAPTER, FEMALE PIPE x BSPP 1/2, MODIFIED	263748-112	1
8	COMPRESSOR, NK40	264154	1
9	VALVE, RELIEF 200 PSI 1/4 NPT MALE	264232	1
10	ADAPTER, FITTING 6MM	264313-011	1
11	SWITCH,TEMP 240 DEG F NC	264325	1
12	WASHER, SEALING BSPP #4	264449-001	3
13	WASHER, SEALING BSPP #8	264449-003	3
14	ADAPTER, MALE PIPE x M-BSPP 1/2	264494-003	1
15	OIL, VANGUARD, 2.5 QT INITIAL FILL, 4.25 QT TOTAL	264626	1
16	HEATER, INLET VALVE 7W 1 x 2	265870	1
17	ADAPTER,1/4-19 BSPP M x 1/8 NPT F	267934	1
18	ELBOW, PIPE GALV 90 DEG 1/2	803515-020	1
19	TEE, PIPE GALV 1/2	804415-020	2
20	NIPPLE, PIPE XS CLOSE 1/2	822208-000	1
21	NIPPLE, PIPE GALV 1/2 x 2	823108-015	1
22	NUT, HEX FLANGE 3/8-16	825306-347	3
23	NUT, HEX LOCKING 1/2-13	825508-262	1
24	CAPSCREW, S.H. M8x1.25 x 30mm	829308-030	5
25	BOLT, CARRIAGE 3/8-16UNC X 2" LG.	829506-200	2
26	BOLT, CARRIAGE 1/2-13UNC X 3" LG.	829508-300	1
27	SCREW, SER WASH 3/8-16 x 1.5	829706-150	1
28	WASHER, FLAT 1/2	838208-112	4

*Continued on page 125*

# 9.3 COMPRESSOR AND PARTS ASSEMBLY (CONT.)

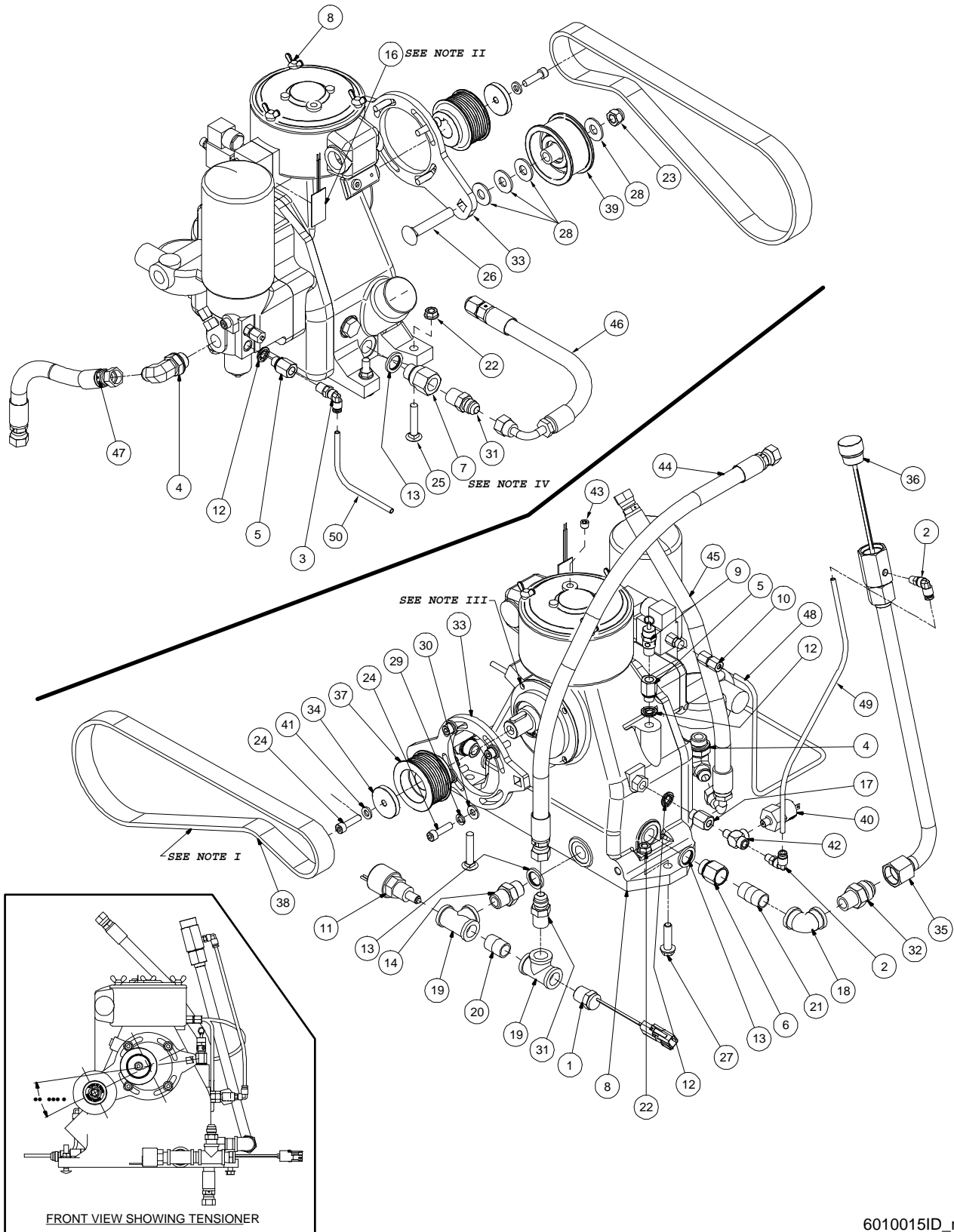

6010015ID\_r1

## 9.3 COMPRESSOR AND PARTS ASSEMBLY (CONT.)

ITEM	DESCRIPTION	PART NUMBER	QTY
29	WASHER, LOCK METRIC M8	838808-200	4
30	WASHER, FLAT METRIC M8	838908-180	4
31	CONNECTOR, 37FL/MPT #08 x 1/2	860108-050	2
32	CONNECTOR, 37FL/MPT #12 x 1/2	860112-050	1
33	TENSIONER, AIR END	A1269736	1
34	WASHER, SHEAVE COMPRESSOR	A1269989	1
35	PIPE, DIPSTICK HOLDER	CM269777	1
36	DIPSTICK, OIL LEVEL	CM269778	1
37	SHEAVE, DRIVE "K" SECTION 8 GROOVE	DR269939	1
38	BELT, SERPENTINE	DR270054	1
39	IDLER, 1.375 WIDTH, 3 3/8DIA	DR46584	1
40	SWITCH, PRESSURE N.C. 185 PSI	EL270002	1
41	WASHER, 5/16ID X 21/32OD, 2 PIECE LOCKING	FA21391	1
42	TEE, MALE STREET 1/8 x 1/8 x 1/8	FI31152	1
43	PIPE BRASS, PLUG, COUNTERSUNK 1/8" NPT	FI67437	1
44	COMPRESSOR TO OIL COOLER	TU270069-001	1
45	COMPRESSOR TO OIL COOLER	TU270069-002	1
46	DRAIN HOSE, COMPRESSOR	TU270069-003	1
47	COMPRESSOR TO AIR ACCUMULATOR	TU270069-004	1
48	TUBE, NK-40	TU270215	1
49	TUBING, 1/4DIA., NYLON, 230 PSI X 1.5 FT	TU95945	1
50	TUBING, 1/4DIA., NYLON, 230 PSI X 3 FT	TU95945.	1

<sup>I</sup> Belt installed prior to idler (consult **Section 6.5.12** when performing maintenance on serpentine belt).

<sup>II</sup> Heat blanket is optional. Consult **Appendix A, Section A.5, Air N Arc 300 Series All-in-One Power System Available Option List**.

<sup>III</sup> Case will leak oil when screws are removed. Do not allow cover to move when performing serpentine belt maintenance

<sup>IV</sup> This fitting must have hex clearance; if not this port will leak.

# 9.4 COOLING SYSTEM

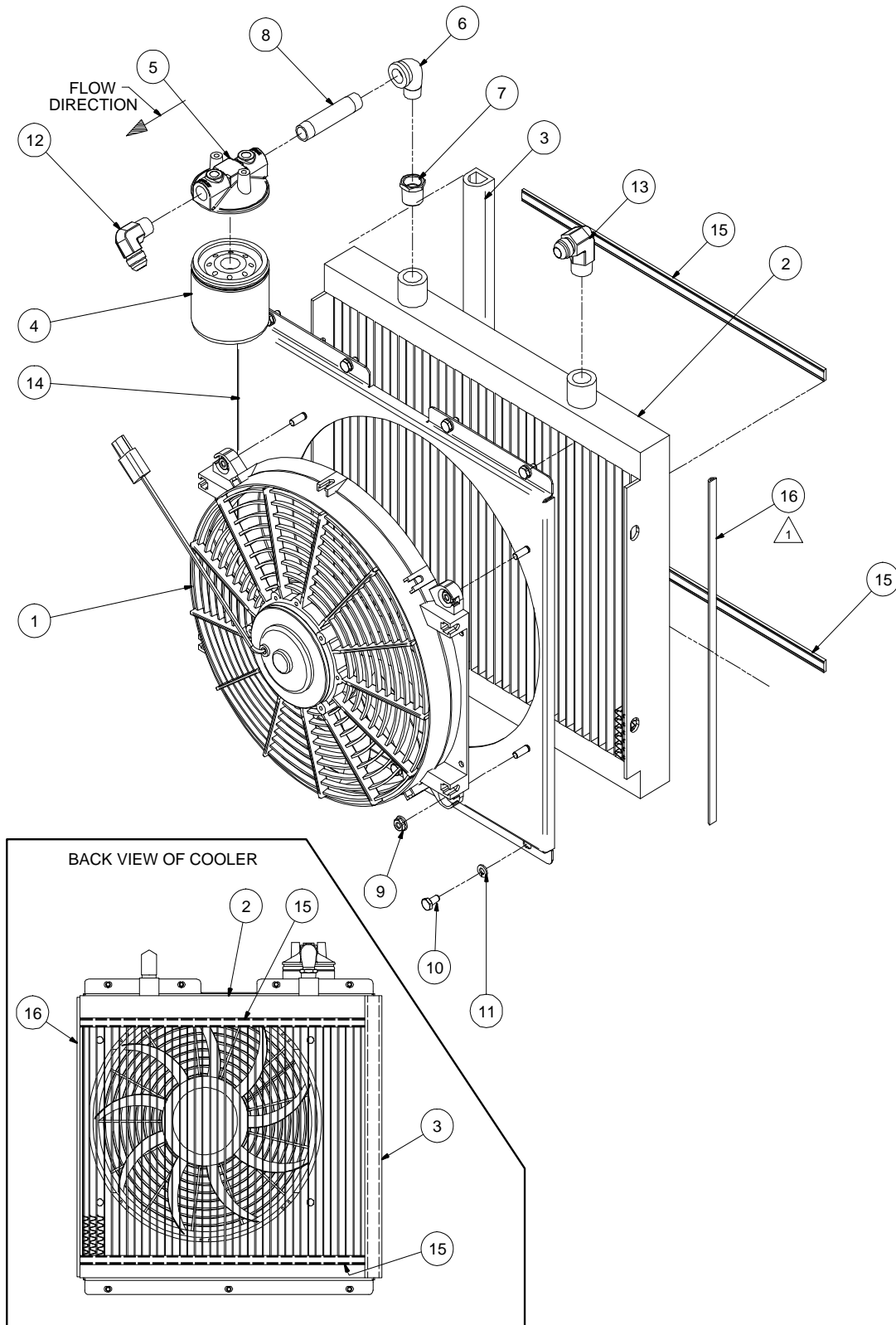

6020017ID\_r1



## 9.4 COOLING SYSTEM

ITEM	DESCRIPTION	PART NUMBER	QTY
1	FAN & MOTOR ASSY. 60-85 CFM	263744	1
2	COOLER, OIL NK40	264121	1
3	SEAL, RUBBER "D" TRIM-LOK 1" X 1"	264138	1.3 FT
4	FILTER, OIL 6" TANK	266801	1
5	HEAD, OIL FILTER 3/8"	268264	1
6	ELBOW, PIPE STREET 3/8	801115-015	1
7	BUSHING, RED STEEL 1/2 x 3/8	807602-015	1
8	NIPPLE, PIPE GALV 3/8 x 3	823106-030	1
9	NUT, HEX FLANGE 1/4-20	825304-236	4
10	CAPSCREW,HEX GR5 1/4-20 X 1/2	829104-050	7
11	WASHER, LOCK 1/4	838504-062	7
12	ELBOW, 37FL/90M #08 x 3/8	860208-038	1
13	ELBOW, 37FL/90M #08 x 1/2	860208-050	1
14	SHROUD, COOLER	A1269742	1
15	GASKET, SEAL AND TRIM, 16-1/2" LG.	PR35734	2
16	GASKET, ADHESIVE BACK, D SHAPE	PR81501	1.3 FT

# 9.5 FRAME AND CANOPY (1 OF 2)

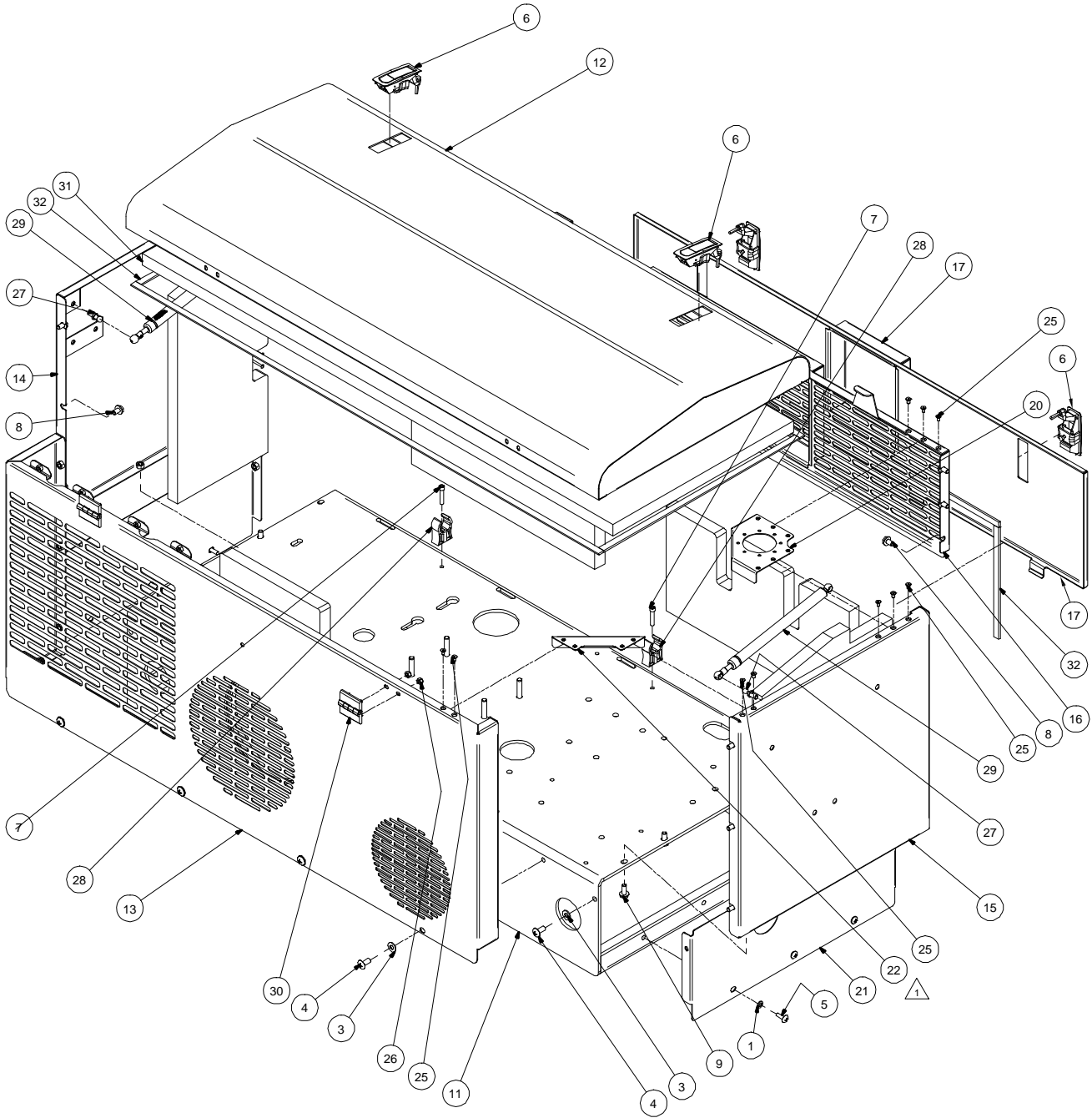

6030007ID\_r1 (1 of 2)

## 9.5 FRAME AND CANOPY (1 OF 2)

ITEM	DESCRIPTION	PART NUMBER	QTY
1	WASHER, NYLON FLAT 1/4	262704	6
2	SEAL, RUBBER AIR INLET 28.5 IN. LG.	262785	1
3	WASHER, NYLON 5/16-18	262943	8
4	SCREW, TRUSS HD 5/16-18 x 3/4 SS	262945	8
5	SCREW, TRUSS HD 1/4-20 x 3/4	262953	6
6	LATCH, SENTRY PANEL	267124	4
7	CAPSCREW, S.H. 1/4-20 x 1 1/4	828304-125	2
8	SCREW, SER WASH 5/16-18 x 0.5	829705-050	16
9	SCREW, SER WASH 5/16-18 X 0.75	829705-075	8
10	SCREW, MACHINE #6-32 X 1	831600-100	4
11	PLATFORM	A1269476	1
12	CANOPY, HOOD	A1269763	1
13	CANOPY, FRONT	A1269764	1
14	CANOPY, SIDE, LH	A1269765	1
15	CANOPY, SIDE, RH	A1269766	1
16	CANOPY, BACK, UPPER	A1269767	1
17	CANOPY, BACK, LOWER	A1269768	1
18	COVER, BASE	A1269769	1
19	SUPPORT, CROSS BRACE	A1269797	1
20	SUPPORT, FUEL FILL NECK	A1269798	1
21	COVER, BASE WITH CUTOUT	A1269980	1
22	SUPPORT, CROSS BRACE	A1270459	1
23	EXHAUST, OUTLET	A14883P	1
24	SWITCH, HOOD SAFETY NO/NC 15A-125V. AC	CO81774	2
25	CAPSCREW, S.H.FLAT #10-24 x 3/8	FA269805	14
26	NUT, LOCK, M6 X 1.0 PITCH	FA55272	9
27	STUD, BALL, .39DIA. X .55LG.	FA58724	4
28	CLIP, DRAIN HOSE HOLDER, 3/4	HA270218	2
29	GAS SPRING, 6 STROKE, 20#	HA72205	2
30	HINGE, 2" X 2", BLACK	HA88014	2
31	KIT, 1" ACOUSTICAL FOAM INSULATION	PR270019	1
32	GASKET, SEAL AND TRIM (16 FT TOTAL)	PR35734	1

# 9.6 FRAME AND CANOPY (2 OF 2)

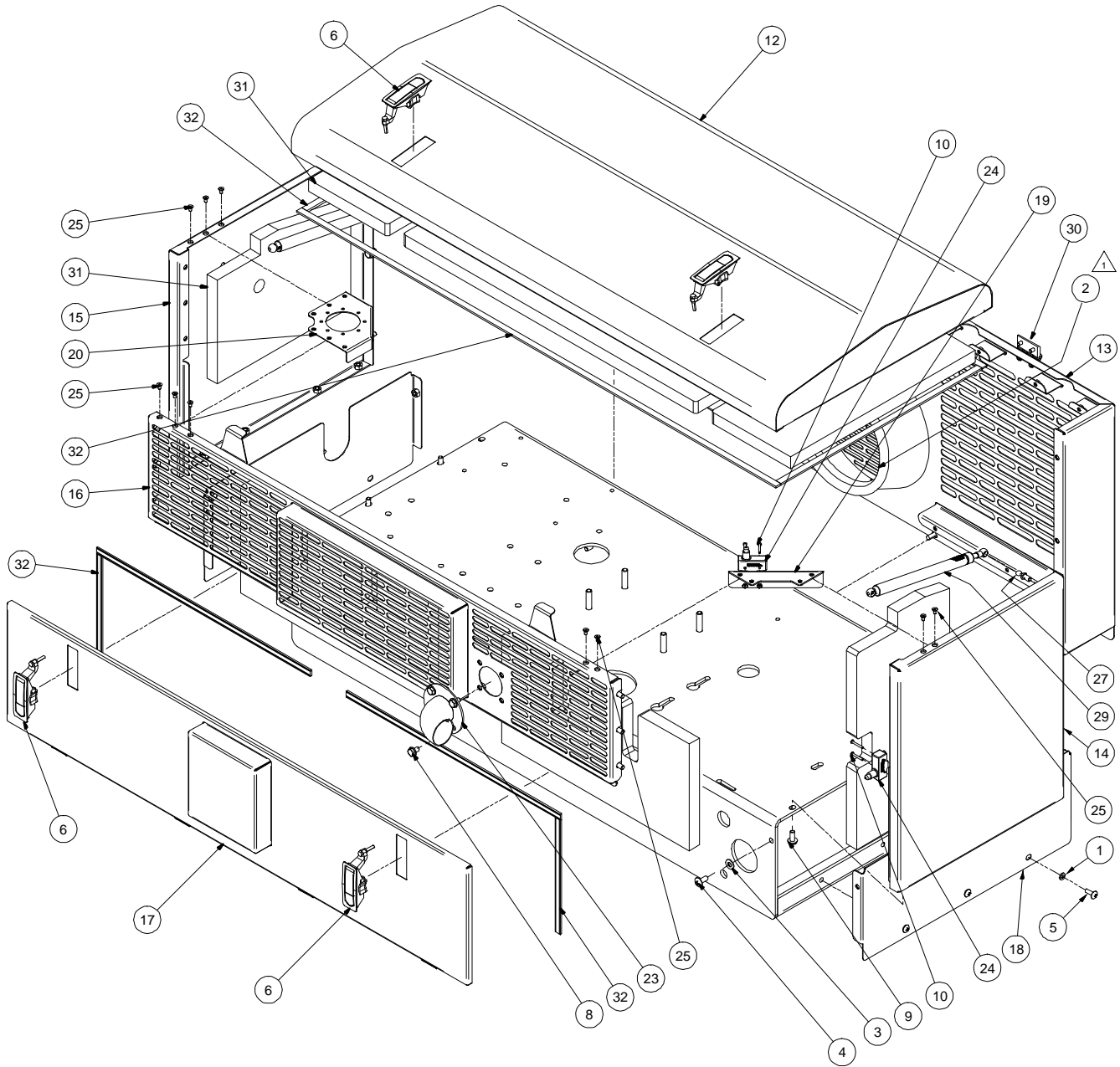

6030007ID\_r1 (2 of 2)

## 9.6 FRAME & CANOPY ASSEMBLY (2 OF 2)

ITEM	DESCRIPTION	PART NUMBER	QTY
1	WASHER, NYLON FLAT 1/4	262704	6
2	SEAL, RUBBER AIR INLET 28.5 IN. LG.	262785	1
3	WASHER, NYLON 5/16-18	262943	8
4	SCREW, TRUSS HD 5/16-18 x 3/4 SS	262945	8
5	SCREW, TRUSS HD 1/4-20 x 3/4	262953	6
6	LATCH, SENTRY PANEL	267124	4
7	CAPSCREW, S.H. 1/4-20 x 1 1/4	828304-125	2
8	SCREW, SER WASH 5/16-18 x 0.5	829705-050	16
9	SCREW, SER WASH 5/16-18 X 0.75	829705-075	8
10	SCREW, MACHINE #6-32 X 1	831600-100	4
11	PLATFORM	A1269476	1
12	CANOPY, HOOD	A1269763	1
13	CANOPY, FRONT	A1269764	1
14	CANOPY, SIDE, LH	A1269765	1
15	CANOPY, SIDE, RH	A1269766	1
16	CANOPY, BACK, UPPER	A1269767	1
17	CANOPY, BACK, LOWER	A1269768	1
18	COVER, BASE	A1269769	1
19	SUPPORT, CROSS BRACE	A1269797	1
20	SUPPORT, FUEL FILL NECK	A1269798	1
21	COVER, BASE WITH CUTOUT	A1269980	1
22	SUPPORT, CROSS BRACE	A1270459	1
23	EXHAUST, OUTLET	A14883P	1
24	SWITCH, HOOD SAFETY NO/NC 15A-125V. AC	CO81774	2
25	CAPSCREW, S.H.FLAT #10-24 x 3/8	FA269805	14
26	NUT, LOCK, M6 X 1.0 PITCH	FA55272	9
27	STUD, BALL, .39DIA. X .55LG.	FA58724	4
28	CLIP, DRAIN HOSE HOLDER, 3/4	HA270218	2
29	GAS SPRING, 6 STROKE, 20#	HA72205	2
30	HINGE, 2" X 2", BLACK	HA88014	2
31	KIT, 1" ACOUSTICAL FOAM INSULATION	PR270019	1
32	GASKET, SEAL AND TRIM (16 FT TOTAL)	PR35734	1



## 9.7 INSTRUMENT PANEL (CONTINUED)

ITEM	DESCRIPTION	PART NUMBER	QTY
1	ELBOW, 1/4T x 1/8P PUSH-ON	261309	1
2	ELBOW, 90 DEG. PUSH ON 1/4T x 1/4P	261310	1
3	WASHER, NYLON 5/16-18	262943	2
4	BUSHING, PIPE BRASS 1/4 x 1/2	264093	1
5	RECEPTACLE, 120V/20A	270092	1
6	COUPLING, PIPE 1/8	806230-005	1
7	PLUG, PIPE 1/2	807800-020	2
8	NUT, HEX 1/4-20	825204-226	2
9	NUT, HEX FLANGE 1/4-20	825304-236	4
10	CAPSCREW, HEX GR5 1/4-20 X 1 1/2 LG.	829104-150	2
11	CAPSCREW, HEX GR8 1/4-20 X 3/4 LG	829404-075	6
12	SCREW, SER WASH 5/16-18 x 0.75	829705-075	2
13	WASHER, FLAT 1/4	838204-071	2
14	WASHER, LOCK 1/4	838504-062	8
15	ELBOW, 45 DEG. 1/2 MPT x #8 MJIC	860008-050	1
16	FACEPLATE, CONTROL PANEL	A1269483	1
17	PANEL, CONTROL BACK	A1269489	1
18	CLAMP, CONTROL PANEL CABLE	A1269491	1
19	COVER, CONTROL PANEL CABLE	A1269492	1
20	MODULE, WELD CONTROL SYS ASSY	CO269598	1
21	SWITCH, IGNITION EFI ENGINES	CO269713	1
22	GAUGE, FUEL / HOUR METER	CO269748	1
23	SENSOR, HALL EFFECT WELD CONTROLS	CO269900	1
24	CIRCUIT BREAKER, 25 AMP	CO270157	2
25	PANELMETER, VOLTAGE, LED	CO49659	1
26	KNOB, PLASTIC, 1.3 DIA., 1/4 SHAFT	CO59489	1
27	LAMP, INDICATOR, LED, GREEN	CO59966	5
28	SWITCH, TOGGLE, SPST, ON/OFF	CO78077	2
29	GAUGE, AIR, DRY, 0-200 PSI	CO89649	1

*Continued on page 135*

# 9.7 INSTRUMENT PANEL (CONTINUED)

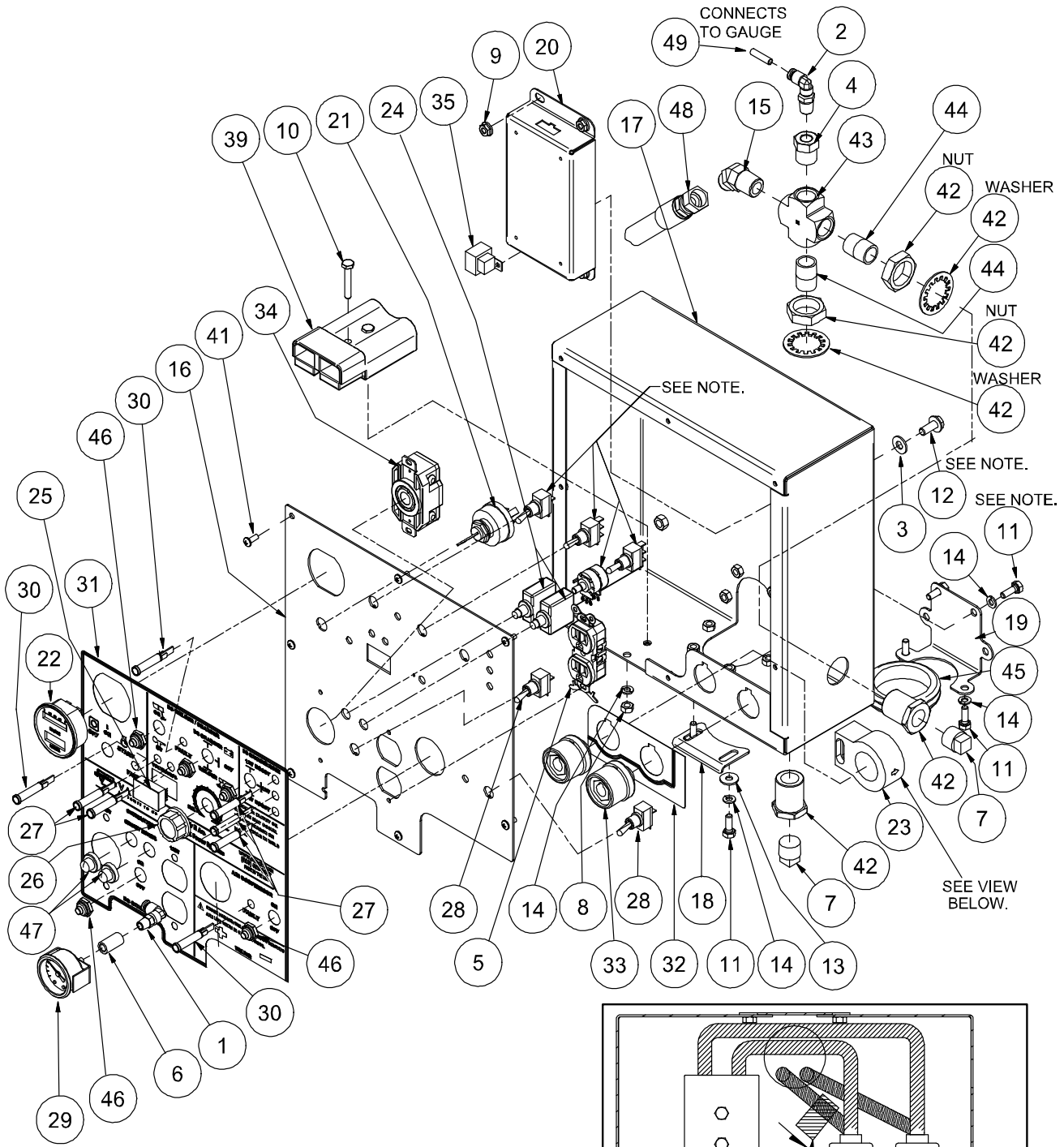

NOTE:  
TOGGLE SWITCHES AND POTENTIOMETER ARE INCLUDED WITH HARNESS #EP269872; WIRING INST PNL SWITCHES.

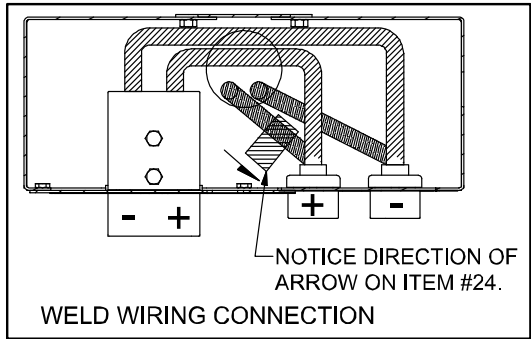

6040010ID\_r0



## 9.7 INSTRUMENT PANEL (CONTINUED)

ITEM	DESCRIPTION	PART NUMBER	QTY
30	LAMP, INDICATOR, LED, RED	CO89659	3
31	DECAL, FACEPLATE	DL269822	1
32	DECAL, CONTROL PANEL, WELDER	DL269822-02	1
33	RECEPTACLE, PANEL 350 AMP	EL269932	2
34	RECEPTACLE, 240V/30A TURNLOC	EL270148	1
35 <sup>I</sup>	HARNESS, WIRE INST PNL	EP269870	1
36	HARNESS, WIRE INST PNL LIGHTS	EP269871	1
37	HARNESS, WIRE INST PNL SWITCH	EP269872	1
38	HARNESS, WIRE INST PNL DISPLAY	EP270055	1
39	HARNESS, WELD CABLE JUMPER	EP270171	1
40	HARNESS, A/C PANEL TO MACHINE	EP270230	1
41	SCREW, PHILLIPS PAN HEAD #10-32 X 1/2" LG. SS	FA33542	7
42	PIPE BRASS, BULKHEAD 1/2 NPT	FI23542	2
43	PIPE BRASS, CROSS (BAR STOCK), 1/2 NPT.	FI25405	1
44	NIPPLE, PIPE XS CLOSE 1/2, BRASS	FI34220	2
45	GROMMET, BLACK RUBBER, 2.25ID	PR74492	1
46	SWITCH BOOT, TOGGLE, WEATHER PROOF	PR77230	5
47	BOOT, BREAKER, PANEL MOUNT	PR81817	2
48	HOSE, AIR TANK TO PANEL	TU270069-006	1
49	TUBING, 1/4 DIA., NYLON, 230 PSI X 1.25 FT	TU95945	1

<sup>I</sup>Relay (50 Amp) is part of harness wire EP269870. To order relay separately, use part no. 267305.

# 9.8 GENERATORS AND PARTS

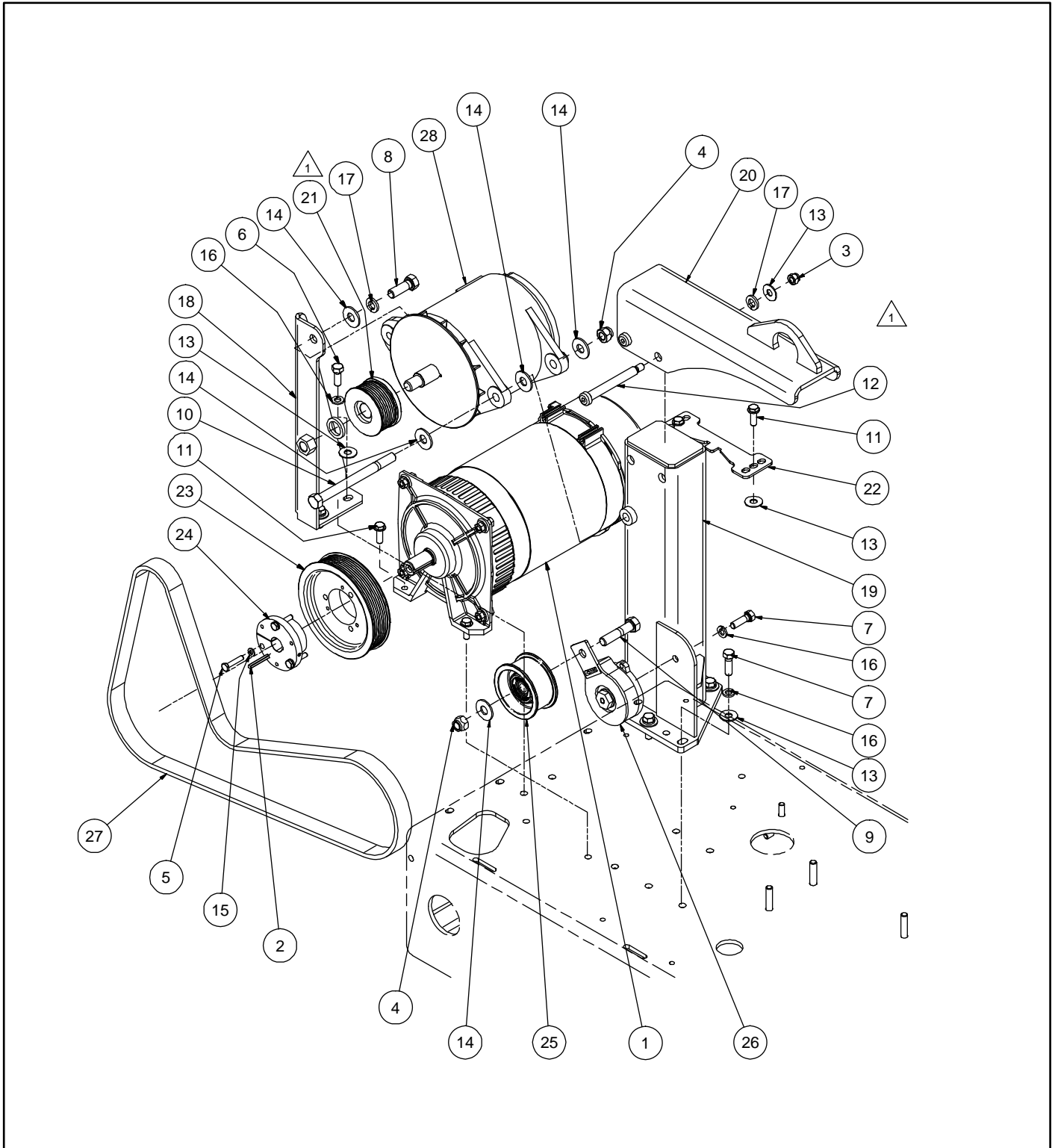

6050004ID\_r1

## 9.8 GENERATORS AND PARTS

ITEM	DESCRIPTION	PART NUMBER	QTY
1	GENERATOR, AC, 6.8KW	269530	1
2	KEY, SQUARE 3/16 x 3/16 x 1.5	821103-150	1
3	NUT, HEX LOCKING 3/8-16	825506-198	2
4	NUT, HEX LOCKING 1/2-13	825508-262	2
5	CAPSCREW, HEX GR5 1/4-20 X 1 1/4	829104-125	3
6	CAPSCREW, HEX GR8 3/8X1	829406-100	2
7	CAPSCREW, HEX GR8 3/8-16X1 1/4	829406-125	6
8	CAPSCREW, HEX GR8 1/2-13X11/2	829408-150	1
9	CAPSCREW, HEX GR8 1/2-13 x 2.25	829408-225	1
10	CAPSCREW, HEX GR8 1/2-13 x 6	829408-600	1
11	SCREW, SER WASH 5/16-18 x 1	829705-100	4
12 <sup>I</sup>	SCREW, MACH SHOULDER 1/2X 3 3/4	830508-375	2
13	WASHER, FLAT 3/8	838206-071	11
14	WASHER, FLAT 1/2	838208-112	5
15	WASHER, LOCK 1/4	838504-062	3
16	WASHER, LOCK 3/8	838506-094	8
17	WASHER, LOCK 1/2	838508-125	3
18	BRACKET, WELD GENERATOR	A1269734	1
19	BRACKET, LIFT BALE / SUPPORT	A1269735	1
20	BRACKET, LIFT BALE	A1270039	1
21	SHEAVE, 8 GROOVE, WELD GENERATOR, KEYED	A1270083	1
22	MOUNT, REAR GENERATOR	A15865P	1
23	SHEAVE, SERPENTINE, 8 GROOVE	A15891Z	1
24	BUSHING, SDS, QD, 7/8DIA.	DR41395Z	1
25	IDLER, 1.375 WIDTH, 3 3/8DIA	DR46584	1
26	TENSIONER, ROTARY, LARGE, 42#	DR61391	1
27	BELT, SERPENTINE, (GATORBACK 4080652) 8 RIB X 65.157", BLACK RUBBER	DR98202	1
28	WELDER, GENERATOR 300AMP HD	GE269529	1

<sup>I</sup>Do not substitute the shoulder screw if lift bail bracket is damaged, or removed and re-installed at a later time; this part is factory-recommended for lifting.

# 9.9 ENGINE AND DRIVE PARTS

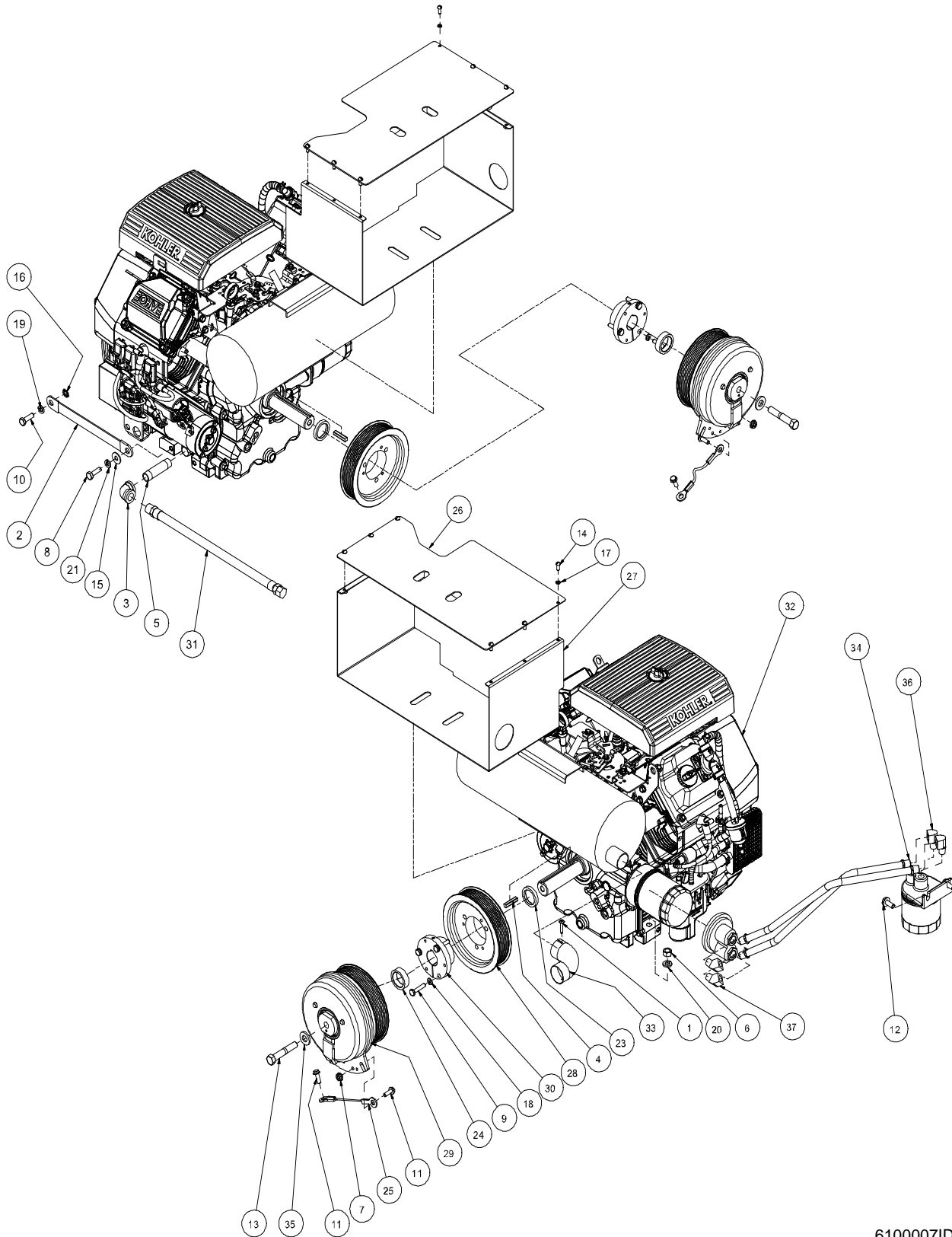

6100007ID\_r0

## 9.9 ENGINE AND DRIVE PARTS (CONTINUED)

ITEM	DESCRIPTION	PART NUMBER	QTY
1	SCREW, SHEET METAL PHIL. #8 X 1 LG.	265590	1
2	STRAP, GROUND 8" w/ 3/8 HOLES	267498	1
3	ELBOW, PIPE GALV 90 DEG 3/8	803515-015	1
4	KEY, SQUARE 1/4 x 1/4 x 1.25	821104-125	1
5	NIPPLE, PIPE GALV 3/8 x 2.5	823106-025	1
6	NUT, HEX 3/8-16	825206-337	4
7	NUT, HEX FLANGE 1/4-20	825304-236	1
8	CAPSCREW, HEX M8-1.25 X 25mm	828008-025	1
9	CAPSCREW, HEX GR5 1/4-20 X 1 1/4 LG.	829104-125	3
10	CAPSCREW, HEX GR5 5/16-18 x 1	829105-100	1
11	SCREW, SER WASH 1/4-20 x 0.75	829704-075	2
12	SCREW, SER WASH 5/16-18 x 0.75	829705-075	2
13 <sup>I</sup>	CAPSCREW, HEX GR8 7/16-20 X 2-1/2 LG.	829807-250	1
14	SCREW, ROUND HD 10-24 x 1/2	831602-050	6
15	WASHER, FLAT 5/16	838205-071	1
16	WASHER, EXTERNAL TOOTH 5/16 DIA	838405-034	1
17	WASHER, LOCK #10	838502-047	6
18	WASHER, LOCK 1/4	838504-062	3
19	WASHER, LOCK 5/16	838505-078	1
20	WASHER, LOCK 3/8	838506-094	4
21	WASHER, LOCK METRIC M8	838808-200	1
22 <sup>II</sup>	OIL, MOTOR 10W-30, 2 QT	844300-001	1
23	SPACER, SHORT	A1269738	1
24	SPACER, LONG	A1269739	1
25	CABLE, ASSEMBLY, CLUTCH	A1269740	1
26	SHIELD, UPPER EXHAUST	A1270065	1

*Continued on page 141*

<sup>I</sup> Torque value for fastener is 50-55 ft-lbs.

<sup>II</sup>Not shown.

# 9.9 ENGINE AND DRIVE PARTS (CONTINUED)

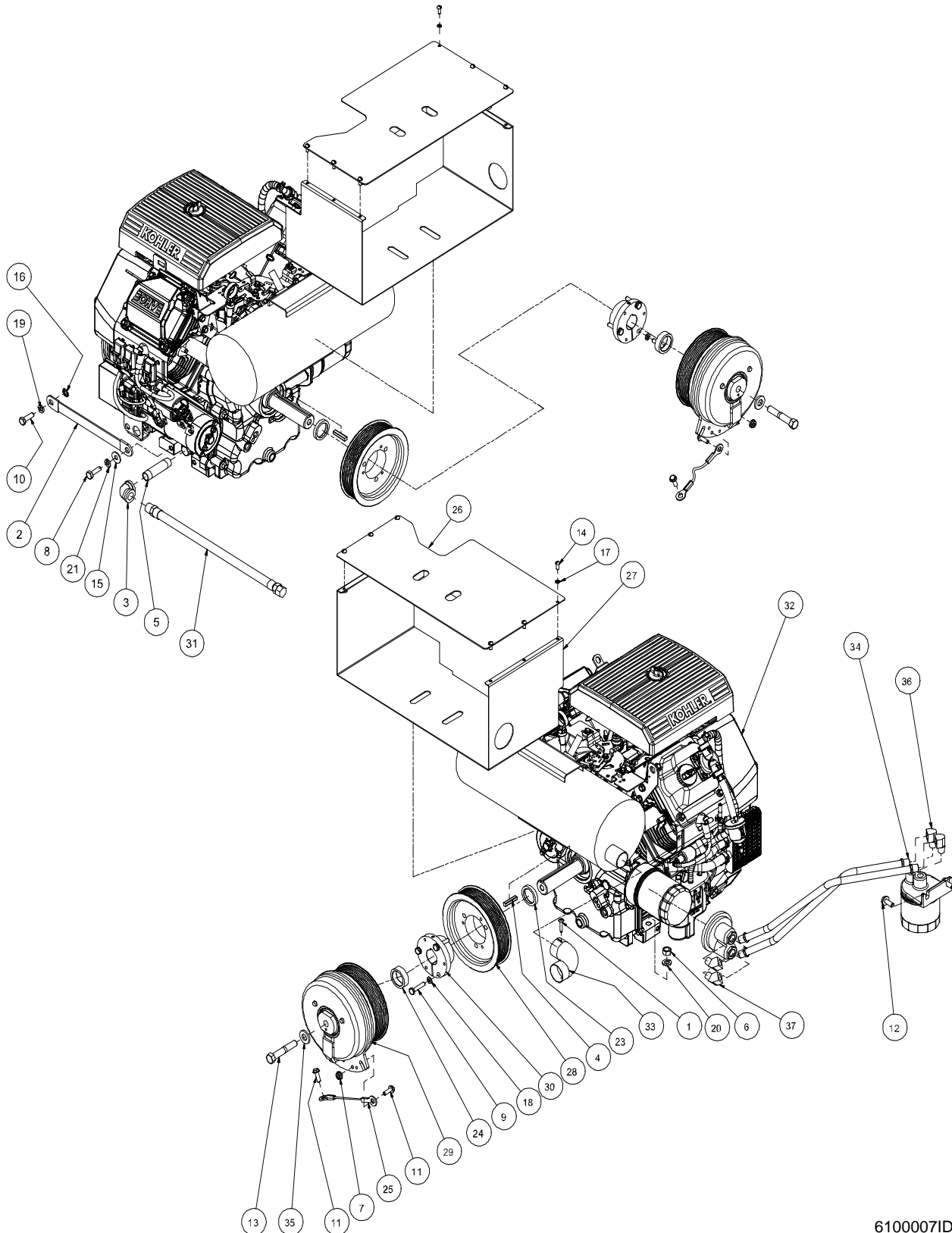

6100007ID\_r0

## 9.9 ENGINE AND DRIVE PARTS (CONTINUED)

ITEM	DESCRIPTION	PART NUMBER	QTY
27	SHIELD, LOWER EXHAUST	A1270066	1
28	SHEAVE, SERPENTINE, 8 GROOVE	A15891Z	1
29	CLUTCH, CMS 5.8 P.D. 8 GRV SHEAVE	DR269574	1
30	BUSHING, SDS, QD, 1 1/8 DIA	DR85785Z	1
31	HOSE, DRAIN 3/8 X 12"LG 3/8 NPT	EN22698	1
32	ENGINE, GAS KOHLER 29 HP EFI	EN269528	1
33	ELBOW, 90 DEG, EXHAUST	EN43384	1
34	FILTER, OIL, REMOTE KIT	EN46765	1
35	WASHER, 1/2ID X 1OD, 2 PIECE LOCKING	FA37629	1
36	PIPE BRASS, 1/4 NPT, 90 DEG. STREET ELBOW	FI65532	2
37	PIPE BRASS, 1/4 NPT, 45 DEG. STREET ELBOW	FI66292	2

# 9.10 ELECTRICAL SYSTEM

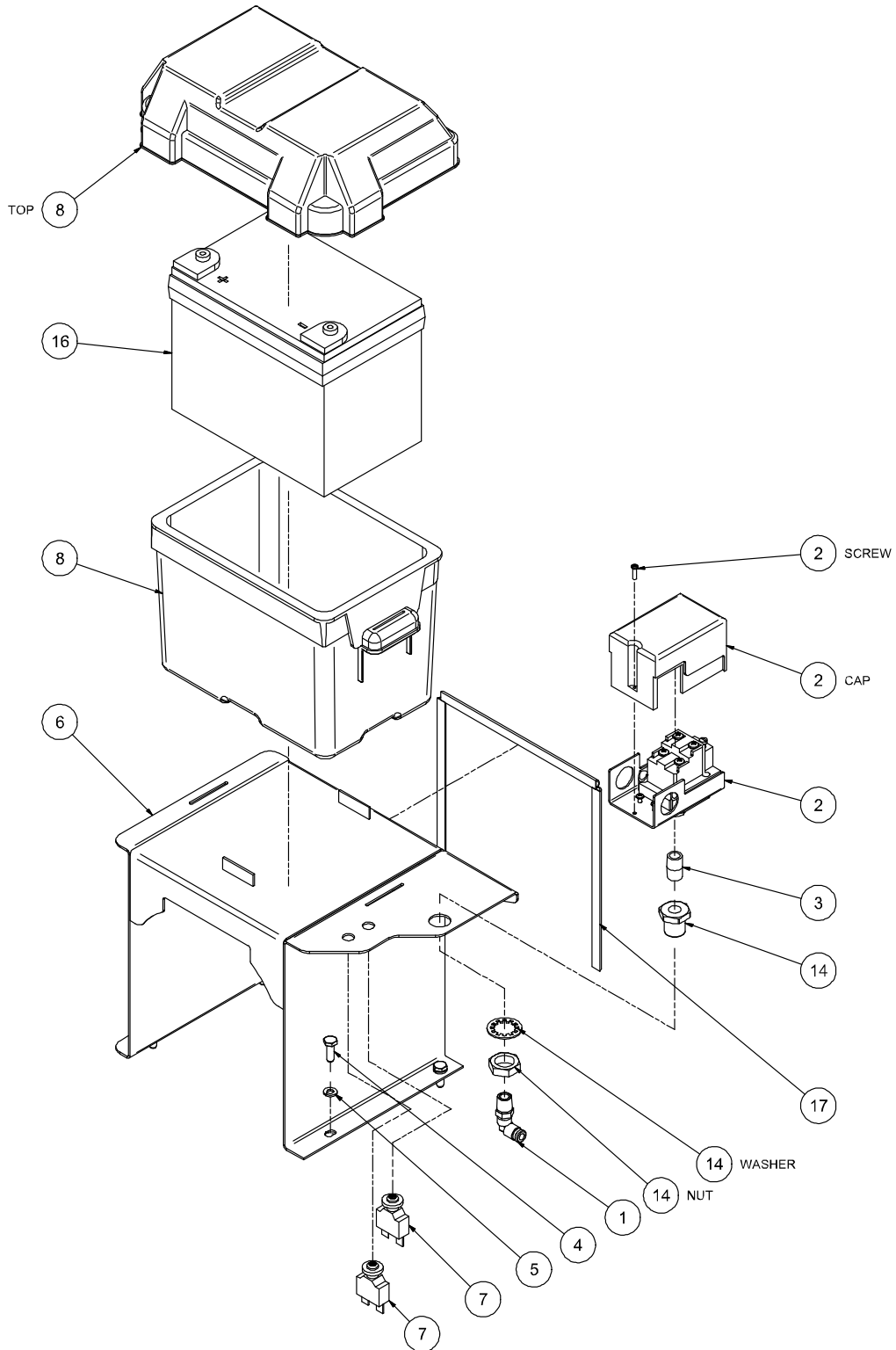

6120040ID\_r0



## 9.10 ELECTRICAL SYSTEM

ITEM	DESCRIPTION	PART NUMBER	QTY
1	ELBOW, 90 DEG. PUSH ON 1/4T x 1/4P	261310	1
2	SWITCH, PRESSURE ADJUSTABLE	263850	1
3	NIPPLE, PIPE XS CLOSE 1/4	822204-000	1
4	CAPSCREW, HEX GR5 1/4-20X 3/4	829104-075	4
5	WASHER, LOCK 1/4	838504-062	4
6	BRACKET, BATTERY	A1270053	1
7	CIRCUIT BREAKER, 30 AMP	CO71774	2
8	BOX, BATTERY	EL269924	1
9 <sup>I</sup>	HARNESS, WIRE MAIN	EP269869	1
10 <sup>I</sup>	HARNESS, WIRE WELDER	EP269873	1
11 <sup>I</sup>	HARNESS, WIRE GENERATOR	EP269874	1
12	CABLE, BATTERY, NEGATIVE	EP34513	1
13	CABLE, BATTERY, POSITIVE	EP85812	1
14	PIPE BRASS, BULKHEAD 1/4 NPT	FI45068	1
15 <sup>II</sup>	WD, AIR N ARC, 300	ID269868	1
16	BATTERY, 12 VOLT 35 AMP DEEP	MA31821	1
17	GASKET, ADHESIVE BACK, D SHAPE 7-3/4 LG.	PR81501	3

<sup>I</sup>Not shown.

<sup>II</sup>Consult **Section 8.2** and **8.3** for wiring diagrams.



## 9.11 FUEL TANK ASSEMBLY

ITEM	DESCRIPTION	PART NUMBER	QTY
1	CLAMP,HOSE SUPPORT .50	261837	2
2	RIVET, 3/16" DIA, S.S.	263194	8
3	CLAMP, HOSE, #6, 5/16" - 7/8"	264787	7
4	LOOM, FIBERGLASS HIGH TEMP 1/2" X 7" LG.	270242	1
5	LOOM, FIBERGLASS HIGH TEMP 1/2" X 6" LG.	270242	1
6	CLAMP, HOSE, #24, 1"-2" DIA.	270493	2
7	PLUG, PIPE 1/4	807800-010	1
8	NUT, HEX LOCKING #10-24	825502-083	2
9	NUT, HEX LOCKING 5/16-18	825505-166	6
10	WASHER, FLAT 5/16	838205-071	6
11	FUEL TANK, 12 GAL	A1269741	1
12	TUBE, FUEL PICK UP	A1269744	1
13	FUEL FILL NECK	A1270005	1
14	BRACKET, WIRING HARNESS	A1270047	1
15	SENDER UNIT, FUEL LEVEL, 6.50 LG	CO269912	1
16	ADAPTER,1/2" HOSE BARB / 1/2" MALE PIPE	FI270258	1
17	CAP, UNLEADED GAS, VENTED	HA270038	1
18 <sup>‡</sup>	FILTER, INLINE FUEL 1/4-5/16"	RC81465	1
19	HOSE, FUEL 1/4" X 0.5' LG. SAE 30R9 CARB	TU269439	1
20	1-1/2" DIA HOSE, FUEL, LOW PRESSURE SAE, 16-1/2" LG.	TU269928	1
21	HOSE, FUEL 5/16" X 1.5" LG. SAE 30R9	TU270137	1
22	HOSE, FUEL 1/2" SAE 30R9, 17-1/2" LG.	TU270224	1

<sup>‡</sup>Arrow direction on filter points upward.

# 9.12 AIR STORAGE ASSEMBLY

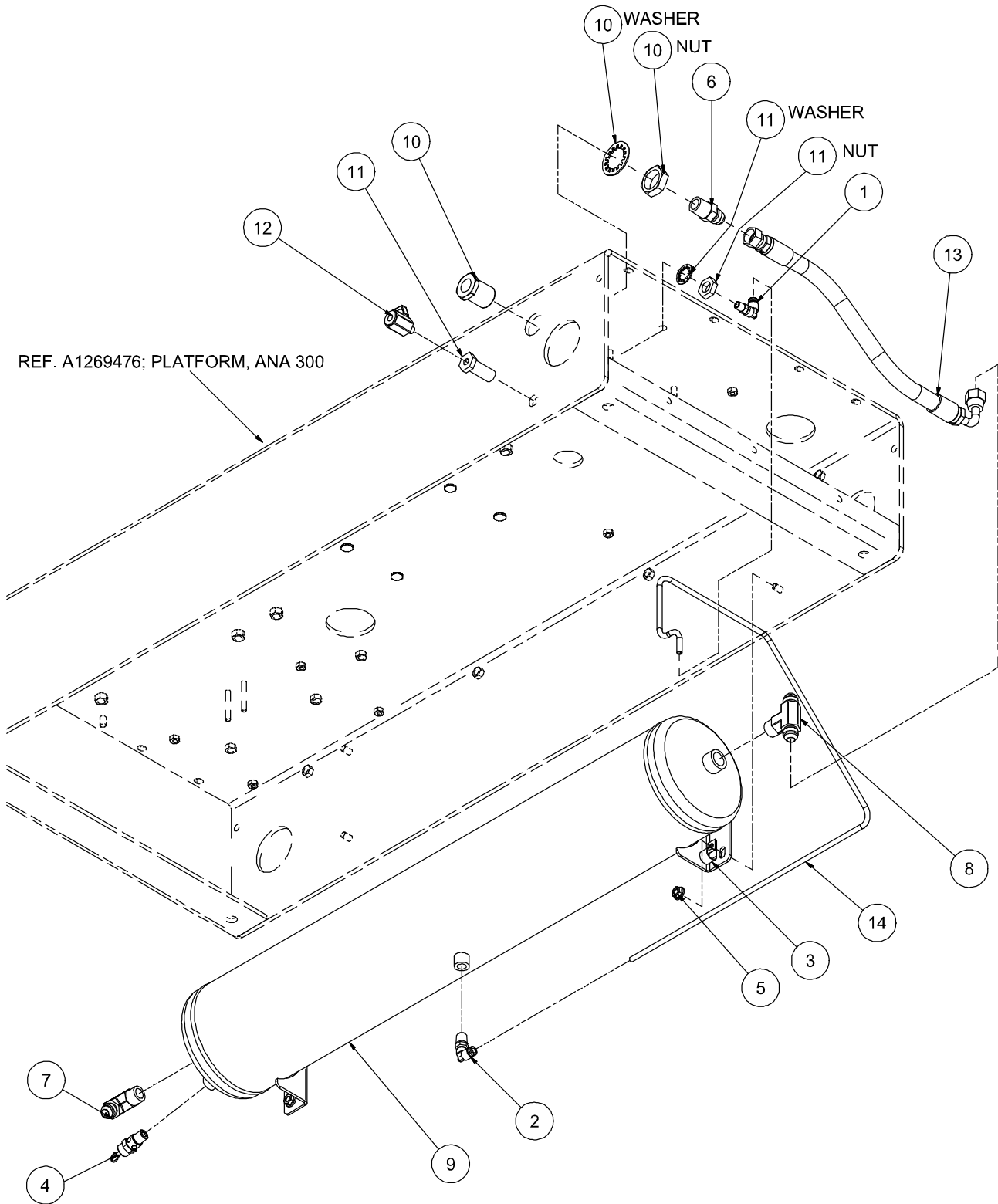

6000027ID\_r0

## 9.12 AIR STORAGE ASSEMBLY

ITEM	DESCRIPTION	PART NUMBER	QTY
1	ELBOW, 1/4T x 1/8P PUSH-ON	261309	1
2	ELBOW, 90 DEG. PUSH ON 1/4T x 1/4P	261310	1
3	CLAMP, HOSE SUPPORT .50	261837	1
4	VALVE, RELIEF 200 PSI 1/4 NPT MALE	264232	1
5	NUT, HEX FLANGE 5/16-18	825305-283	4
6	CONNECTOR, 37FL/MPT #08 x 1/2	860108-050	1
7	ELBOW, 37FL/90M #08 x 1/2	860208-050	1
8	TEE, 37FL/M BR #8 x 1/2	861708-050	1
9	TANK, AIR ACCUMULATOR 4 GAL	A1269633	1
10	PIPE BRASS, BULKHEAD 1/2 NPT	FI23542	1
11	PIPE BRASS, BULKHEAD 1/8 NPT	FI54337	1
12	VALVE, BALL MINI, 1/8 NPT M/F,	FI95272	1
13	HOSE, AIR TANK TO SERVICE PORT	TU270069-005	1
14	TUBING, 1/4 DIA., NYLON, 230 PSI X 3.5 FT	TU95945	1

# 9.13 DECAL AND PLATE LOCATIONS (1 OF 4)

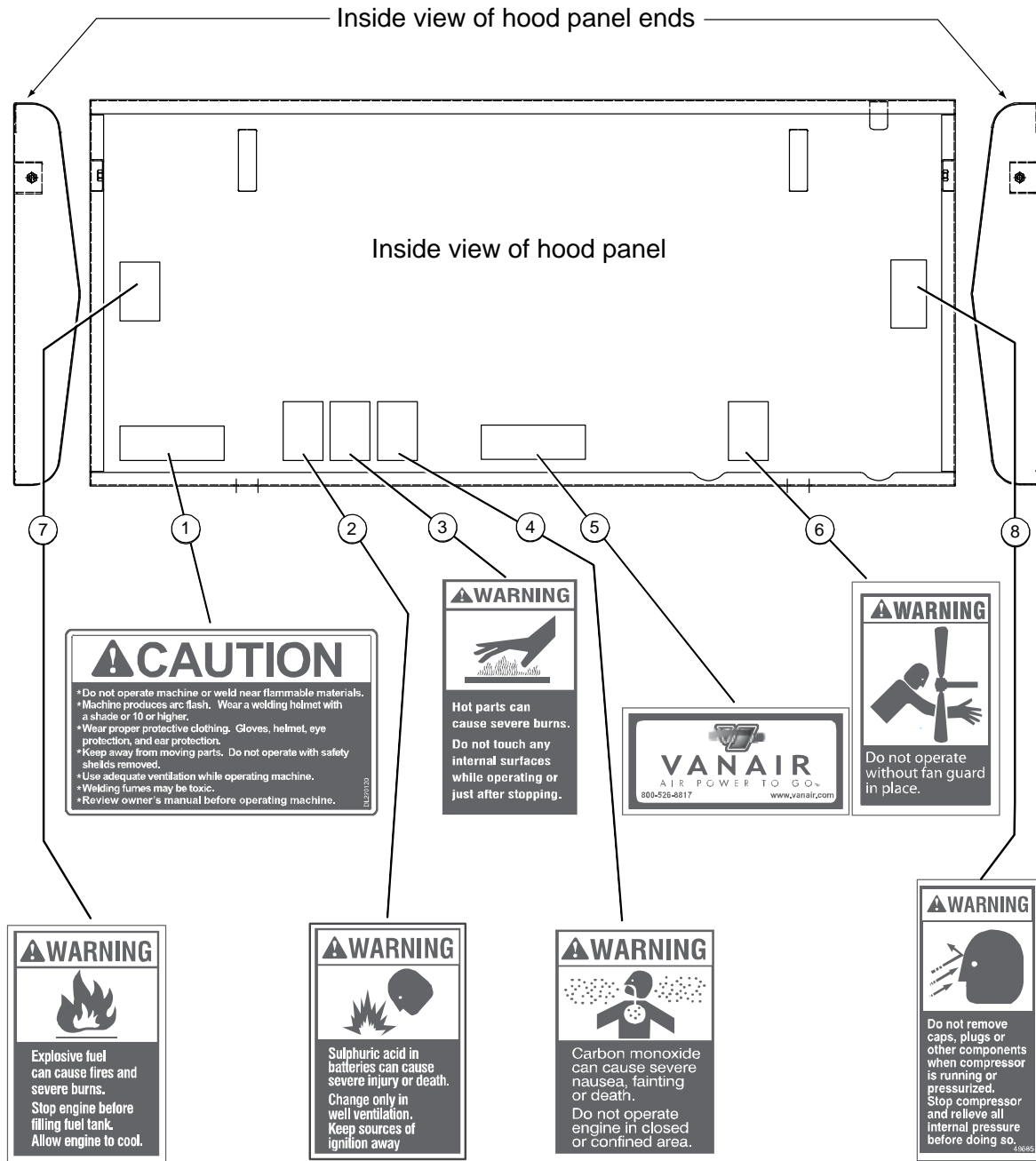

## 9.13 DECAL AND PLATE LOCATIONS (1 OF 4)

ITEM	DESCRIPTION	PART NUMBER	QTY
1	DECAL, CAUTION	DL270120	1
2	DECAL, SULPHURIC ACID	264375 <sup>I</sup>	1
3	DECAL, HOT PARTS	264372 <sup>I</sup>	1
4	DECAL, CARBON MONOXIDE	264376 <sup>I</sup>	1
5	DECAL, VANAIR	265605 <sup>I</sup>	1
6	DECAL, CAP REMOVAL	049685 <sup>I</sup>	1
7	DECAL, EXPLOSIVE FUEL	264377 <sup>I</sup>	1
8	DECAL, FAN GUARD	264383 <sup>I</sup>	1

<sup>I</sup>This decal is included with decal sheet no. 263453.



### 9.13 DECAL AND PLATE LOCATIONS (2 OF 4)

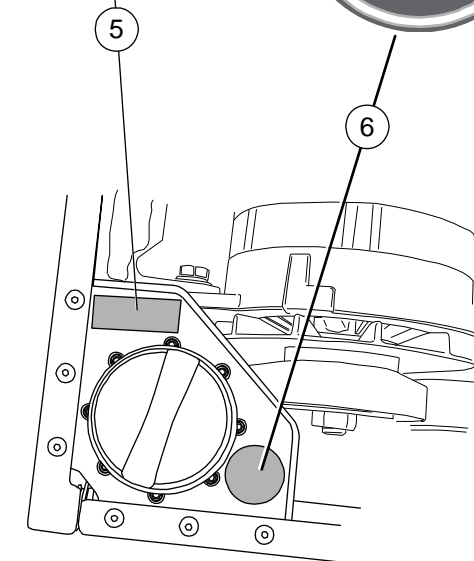
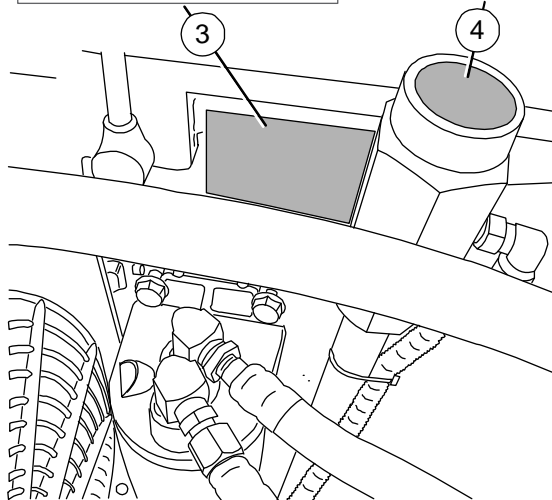
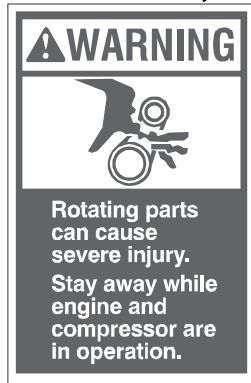
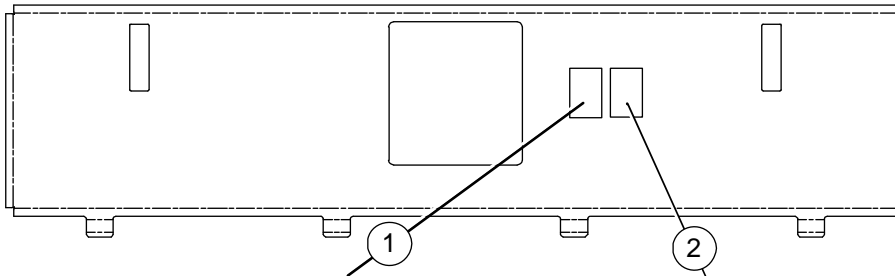



## 9.13 DECAL AND PLATE LOCATIONS (2 OF 4)

ITEM	DESCRIPTION	PART NUMBER	QTY
1 <sup>I</sup>	DECAL, ROTATING PARTS	264374	1
2 <sup>I</sup>	DECAL, ACCIDENTAL STARTS	264373	1
3	DECAL, VANGUARD OIL	263533-2	1
4	DECAL, VANGUARD OIL FILL CAP	263533-1	1
5 <sup>I</sup>	DECAL, GAS ONLY	—	1
6	DECAL, DO NOT USE E-85	DL270183	1

<sup>I</sup>This decal is included with decal sheet no. 263453.



### WARNING

**DO NOT REMOVE OR COVER ANY SAFETY DECAL. Replace any safety decal that becomes damaged or illegible.**

# 9.13 DECAL AND PLATE LOCATIONS (3 OF 4)

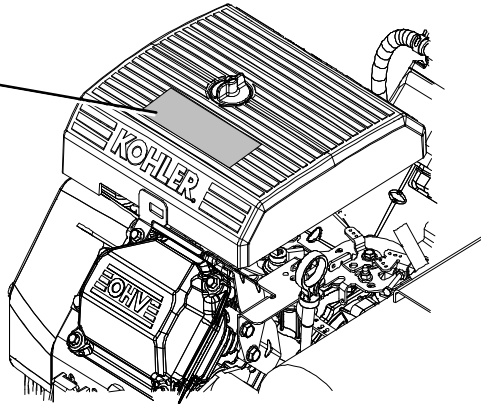
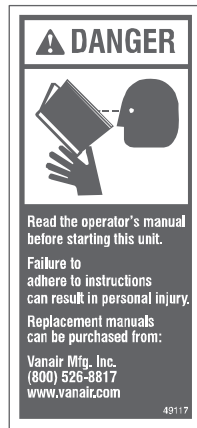

**ENGINE OIL DRAIN**

2

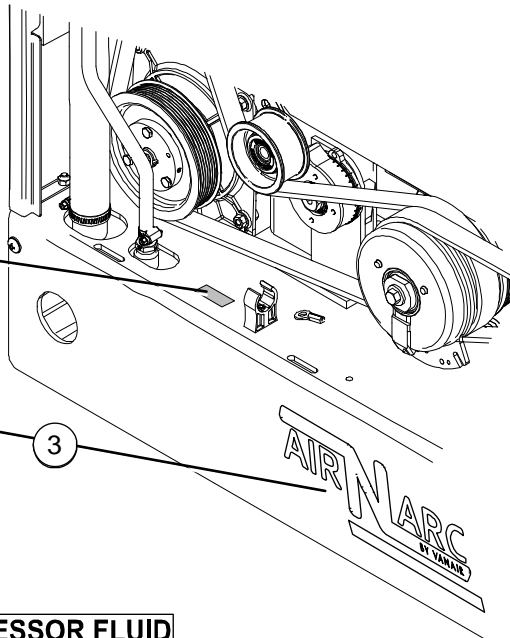

3



**COMPRESSOR FLUID DRAIN**

4

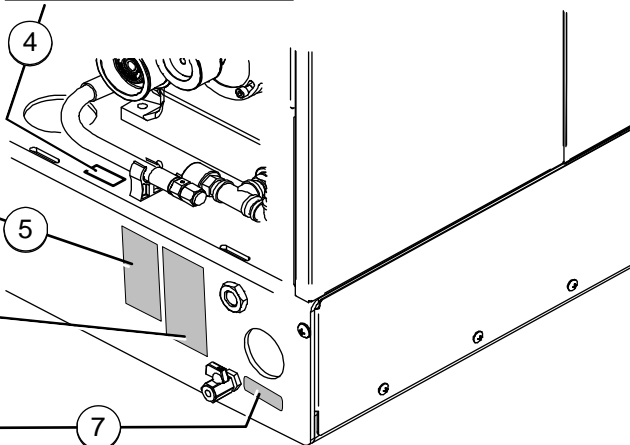

5

6

7

**AIR TANK DRAIN**  
*Drain Daily*

## 9.13 DECAL AND PLATE LOCATIONS (3 OF 4)

ITEM	DESCRIPTION	PART NUMBER	QTY
1 <sup>‡</sup>	DECAL, READ MANUAL	049117	1
2 <sup>‡</sup>	DECAL, ENGINE OIL DRAIN	ANA82	1
3	DECAL, ANA BY VANAIR, WHT	269706	1
4 <sup>‡</sup>	DECAL, COMPRESSOR FLUID DRAIN	—	1
5 <sup>‡</sup>	DECAL, AIR HOSE	261885	1
6 <sup>‡</sup>	DECAL, BREATHING AIR	361886	1
7	DECAL, AIR TANK DRAIN	ANA27	1

<sup>‡</sup>This decal is included with decal sheet no. 263453.

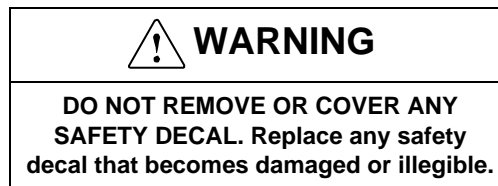

# 9.13 DECAL AND PLATE LOCATIONS (4 OF 4)

### Front View

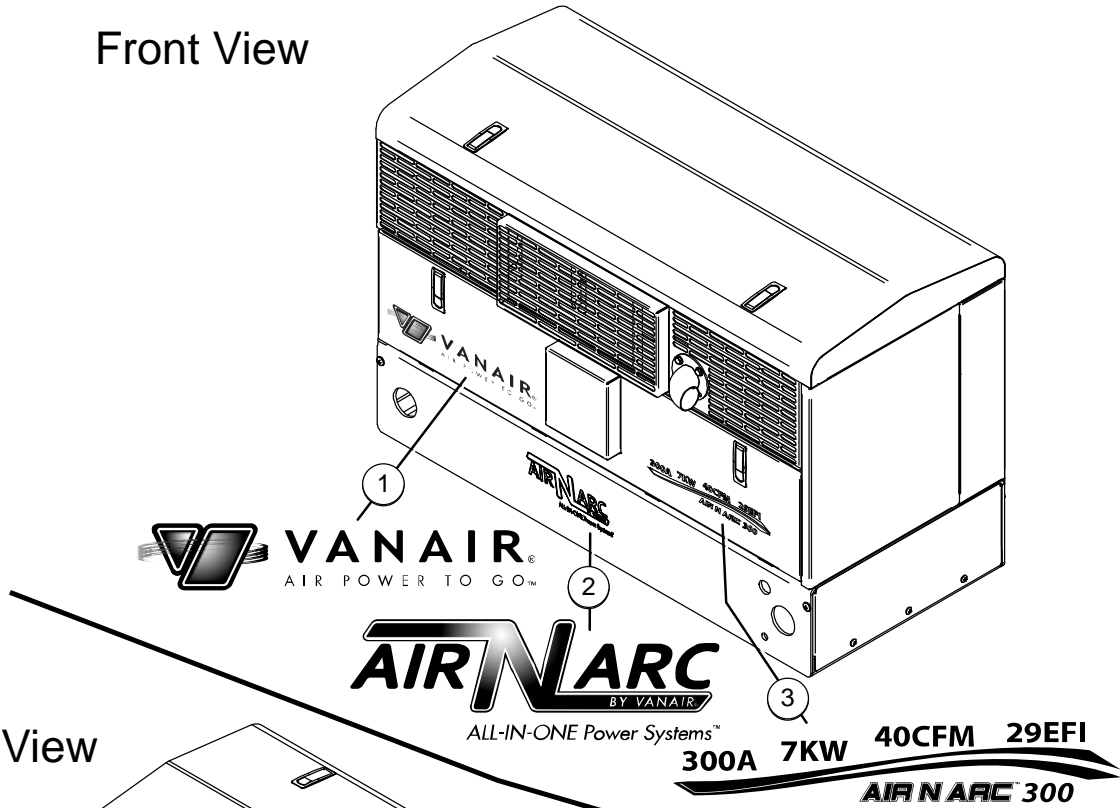

### Rear View



## 9.13 DECAL AND PLATE LOCATIONS (4 OF 4)

ITEM	DESCRIPTION	PART NUMBER	QTY
1	DECAL, ANA 300 VANAIR LOGO 16.5"	DL269707	1
2	DECAL, ANA BY VANAIR WHT.	269706	2
3	DECAL, ANA 300 PERF BADGE BLK.	DL269703	1
4	DECAL, ANA 300 PERF BADGE WHT.	DL269704	1
5	DECAL, ANA 300 VANAIR LOGO 21"	DL269709	1

**NOTE:** For location of machine serial number plate, see *Figure 9-1*.

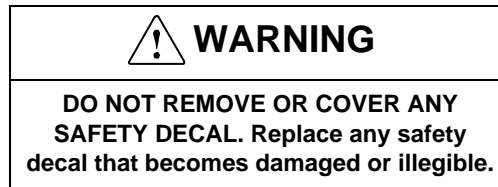

**BLANK PAGE**

# APPENDIX A: ADDITIONAL INFORMATION

## A.1 ELECTRIC MOTOR CHART - STARTING WATTS<sup>I</sup>

### NOTE

For pumps, air compressors, air conditioners, inverters add at least 25% to starting current.

HORSEPOWER	RUNNING WATTS	UNIVERSAL MOTOR (sm. appliance)	INDUCTION MOTOR	CAPACITOR MOTOR	SPLIT PHASE MOTOR
1/6	275	400	600	850	1200
1/4	400	500	850	1050	1700
1/3	450	600	950	1350	1950
1/2	600	750	1300	1800	2600
3/4	850	1000	1900	2600	X
1	1000	1250	2300	3000	X
1 1/2	1600	1750	3200	4200	X
2	2000	2350	3900	5100	X
3	3000	X	5200	6800	X
5	4800	X	7500	9800	X

<sup>I</sup>Approximate current requirements.

**A.2 EXTENSION CORD CHART**

CONTINUOUS LOAD (use either Amps or Watts below)			MINIMUM GAUGE (AWG)		
AMPS	@120 volts	@240 volts	0-50 feet	50-100 feet	100-150 f
2	240	480	22	20	18
3	360	720	22	18	16
4	480	960	20	16	16
5	600	1200	18	16	14
6	720	1440	18	16	14
8	960	1920	16	14	12
10	1200	2400	16	12	12
12	1440	2880	16	12	10
14	1680	3660	14	12	10
16	1920	3840	14	10	10
18	2160	4320	14	10	8
20	2400	4800	12	10	8
22	2640	5280	12	10	8
25	3000	6000	12	10	6
30	3600	7200	10	8	6
35	4200	8400	10	8	4
40	4800	9600	8	6	2
50	6000	12000	6	4	2
60	7200	14400	4	2	



**A.3 WATTAGE REQUIREMENTS FOR COMMON RECEPTACLE UNITS**

COMMON RECEPTICAL UNIT		WATTAGE	
		STARTING	RUNNING
Battery charger, 10 amps		-	200
Drill	- 1/4"	400	300
	- 3/8"	650	475
	- 1/2"	900	750
	- 1"	1250	1000
Welder 100 amps DC		-	3600
Floodlight		--	1000
Grain cleaner, 1/4 HP		1000	650
Grain elevator, 3/4 HP		3000	1400
Grinders (by motor size)			
Heater radiant portable		--	1300
Heater portable liquid fuel	- 50,000 btu	675	225
	- 100,000 btu	1260	420
	- 150,000 btu	1875	625
Impact wrench	- 1/2"	750	600
	- 3/4"	900	750
	- 1"	1400	1200
Milk cooler		1800	1100
Mixer, 3 ½ cubic feet		2300	1000
Motors			
Belt sander		2600	1200
Disc sander		2600	1200
Orbital sander		2600	1200
Chain saw			
6" circular saw		2200	950
7 ¼" circular saw		2600	1200
8 ½" circular saw		3000	1500
10" circular saw		3900	2000
Sump pump		1300	400
Water pump submersible	- 3000 gph	1750	500
	- 5000 gph	2500	650
	- 10000 gph	3750	1000
	- 15000 gph	5000	1500
Water pump non-submersible	- 3000 gph	2250	600
	- 5000 gph	2850	750
	- 10000 gph	4100	1100
	- 15000 gph	5250	1600

<b>A.4 AIR TOOL AIR CONSUMPTION CHART</b>	
<b>TOOL</b>	<b>AIR REQUIRED CFM @ 90 PSI</b>
Dual Action (DA) Sanders	4-6 CFM
5" High Speed Sanders	4-6 CFM
Jitterbug Sanders	4 CFM
Straight Line Sanders	4 CFM
Air Belt Sanders	5.5 CFM
Air Belt Sanders	4 CFM
Gasket Scrapers	6 CFM
Air Punch and Flange Tool	4 CFM
3/8" Drill	4 CFM
1/2 " Drill	4 CFM
Screw Driver	2.5 CFM
Impact Screw Driver	4 CFM
Speed Saw	5-6 CFM
Body Saw	8 CFM
Jig Saw	6 CFM
16 Gauge Nibbler	4 CFM
Cut Off Tool	4 CFM
150 mm Air Hammer	4 CFM
190 mm Air Hammer	4.2 CFM
High Speed Grinder	8 CFM
Mini Air Grinder	3 CFM
Mini Angle Head Grinder	3 CFM
1/4" Angle Head Grinder	8 CFM
Tire Buffer	4 CFM
1/4" Ratchet Wrench	3 CFM
3/8" Ratchet Wrench	4 CFM
3/8" Butterfly Impact Wrench	3 CFM
1/2" Impact Wrench	4 CFM
1/2" Heavy Duty Impact Wrench	5.5 CFM
3/4" Impact Wrench	7.5 CFM
3/4" Impact Wrench with 6" anvil	7.5 CFM
30 lbs Pavement Breaker	37 CFM
<i>Continued on next page</i>	

**A.4 AIR TOOL AIR CONSUMPTION CHART (CONTINUED)**

TOOL	AIR REQUIRED CFM @ 90 PSI
60 lb Pavement Breaker	48 CFM
90 lb Pavement Breaker	68-85 CFM
4" Piercing Tool	60 CFM
60 lb 1650 BPM Rock Drill	95 CFM
50 lb 1800 BPM Rock Drill	123 CFM
40 lb 1800 BPM Rock Drill	82 CFM
30 lb 2300 BPM Rock Drill	55 CFM
Chipping Hammers	26-33 CFM

**A.5 AIR N ARC 300 SERIES ALL-IN-ONE POWER SYSTEM AVAILABLE OPTIONS LIST**

KEY NO.	OPTION ITEM	DESCRIPTION	PART ORDER NUMBER	QTY
1	COMPRESSOR UNLOAD SOLENOID HEATER BLANKET	This heater component is integrated with the electronic fan system so that anytime that compressor switch is on, the blanket is on if the fan is not running.  For cold conditions: <ul style="list-style-type: none"> <li>Let the machine warm up with all switches off</li> <li>After the machine has warmed up the compressor can be turned on.</li> </ul>	265870	1
2	BATTERY BOOST CABLES	These cables are 25 feet in length, with quick-connect ends	MA269938	1 set
3	AIR TANK AUTO DRAIN KIT	Automatically drains moisture from the air reservoir	MA66434	1
4	30 GALLON REMOTE AIR TANK ASSEMBLY	This remote-mounted air option allows for an additional capacity for air storage, in addition to the standard four gallon air tank on the machine.	OA49645	1
5	DUAL 14 GALLON (28 GALLON TOTAL) AIR TANK ASSEMBLY	This remote-mounted air option allows for an additional capacity for air storage, in addition to the standard four gallon air tank on the machine.	032708	1
6	SINGLE 14 GALLON AIR TANK ASSEMBLY	This remote-mounted air option allows for an additional capacity for air storage, in addition to the standard four gallon air tank on the machine.	032707	1
7	BATTERY	12 volt, 35 amp, sealed lead acid	MA31821	1
8	BATTERY	LTV, dry cell 100 KSI	MA44454	1

*Continued on next page*

***A.5 AIR N ARC 300 SERIES ALL-IN-ONE POWER SYSTEM AVAILABLE OPTIONS LIST  
(CONTINUED)***

<b>KEY NO.</b>	<b>OPTION ITEM</b>	<b>DESCRIPTION</b>	<b>PART ORDER NUMBER</b>	<b>QTY</b>
9	EXTENSION SEGMENT FOR WELD CABLE	50 feet in length, 1/0 cable with connectors	MA269942	1
10	WELD HELMET	2 x 4 auto-darkening lens, solid color (blue)	MA269903	1
11	WELD HELMET LENSE	Replacement lense for welding shield	MA270500	
12	WELD LEAD	25 feet in length, 1/0 cable with electrode holder and connector - 330 amp	MA269814-25	1
13	WELD LEAD	50 feet in length, 1/0 cable with electrode holder and connector - 330 amp	MA269814-50	1
14	WELD LEAD	25 feet in length, 1/0 cable with ground clamp, and connector - 330 amp	MA269815-25	1
15	WELD LEAD	50 feet in length, 1/0 cable with ground clamp, and connector - 330 amp	MA269815-50	1
16	WELDING ROD	LaGrange 100 KSI 1/8" blue	MA98018	per pound
17	WELDING ROD	LaGrange 100 KSI 3/32" blue	MA44890	per pound
18	WELDING ROD	LaGrange 100 KSI 5/32" blue	MA99727	per pound
19	ISOLATOR (BOLT DOWN)	Used to dampen vibration transferred from direct mounting of package. One per mounting bolt (x 4) needed.	PR93969	4
20	AIR GOUGE TORCH	Torch, air gouge	MA269933	1
21	CARBON ARC ELECTRODES	Cabons, pointed arc gouging 3/16" x 12"	MA269935	50 / box

**A.6 HOSE INSTALLATION GUIDE**

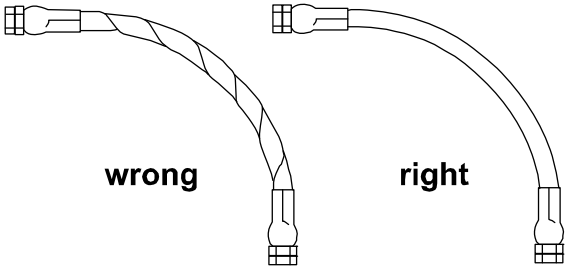
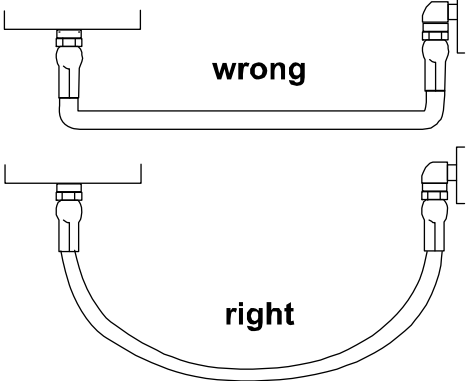
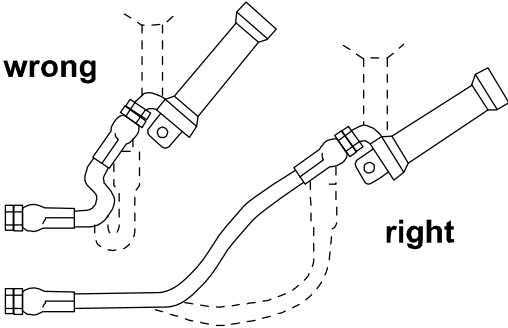
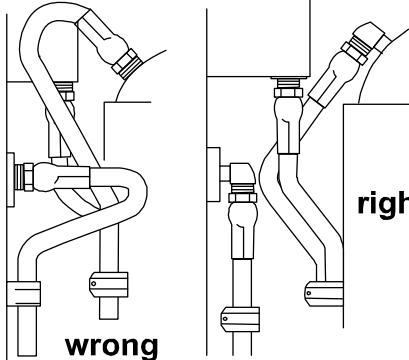
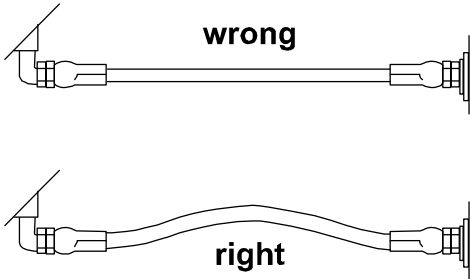
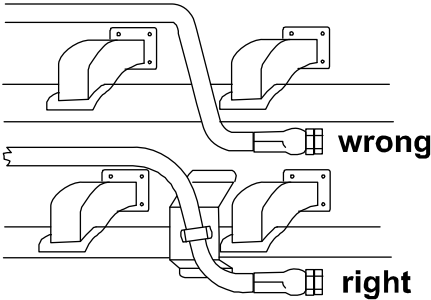
 <p>1. Hose is weakened when installed in twisted position. Pressure in twisted hose tends to loosen fitting connections. Design so that machine motion produces bending rather than twisting.</p>	 <p>2. Ample bend radius should be provided to avoid collapsing of line and restriction of flow.</p>
 <p>3. Exceeding minimum bend radius will greatly reduce hose assembly life.</p>	 <p>4. Use elbows or other adapters as necessary to eliminate excess hose length and to insure neater installation for easier maintenance.</p>
 <p>5. When hose assembly is installed in a flexing application, remember that metal hose fittings are not part of the flexible portion. Allow ample free length for flexing.</p>	 <p>6. When properly routing, use clamps to secure the hose in its proper position.</p>

**BLANK PAGE**

# APPENDIX B: INSTRUMENT PANEL FUNCTIONS

## B.1 INSTRUMENT PANEL KEY FUNCTION MAP

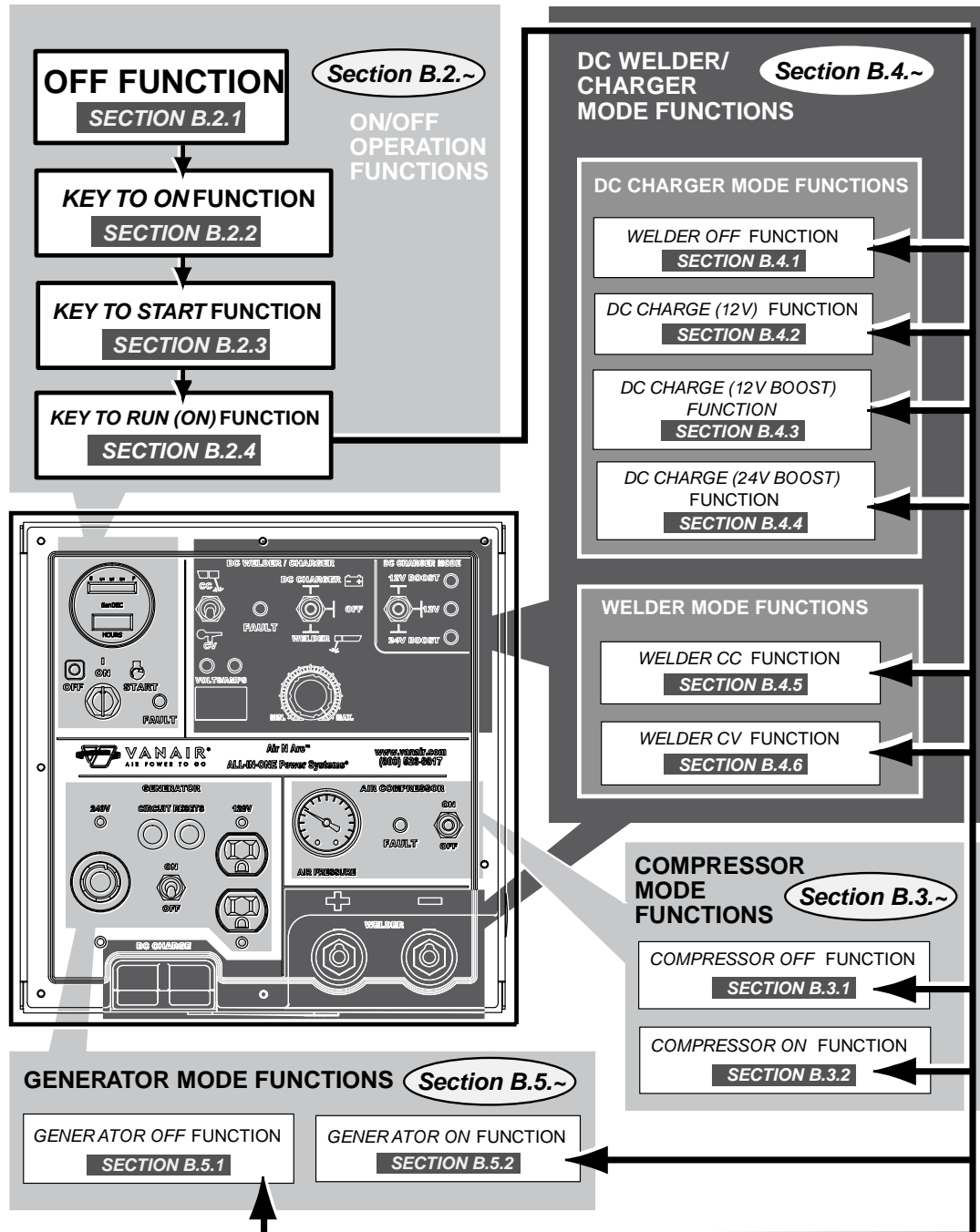

## B.2.1 INSTRUMENT PANEL - OFF FUNCTION

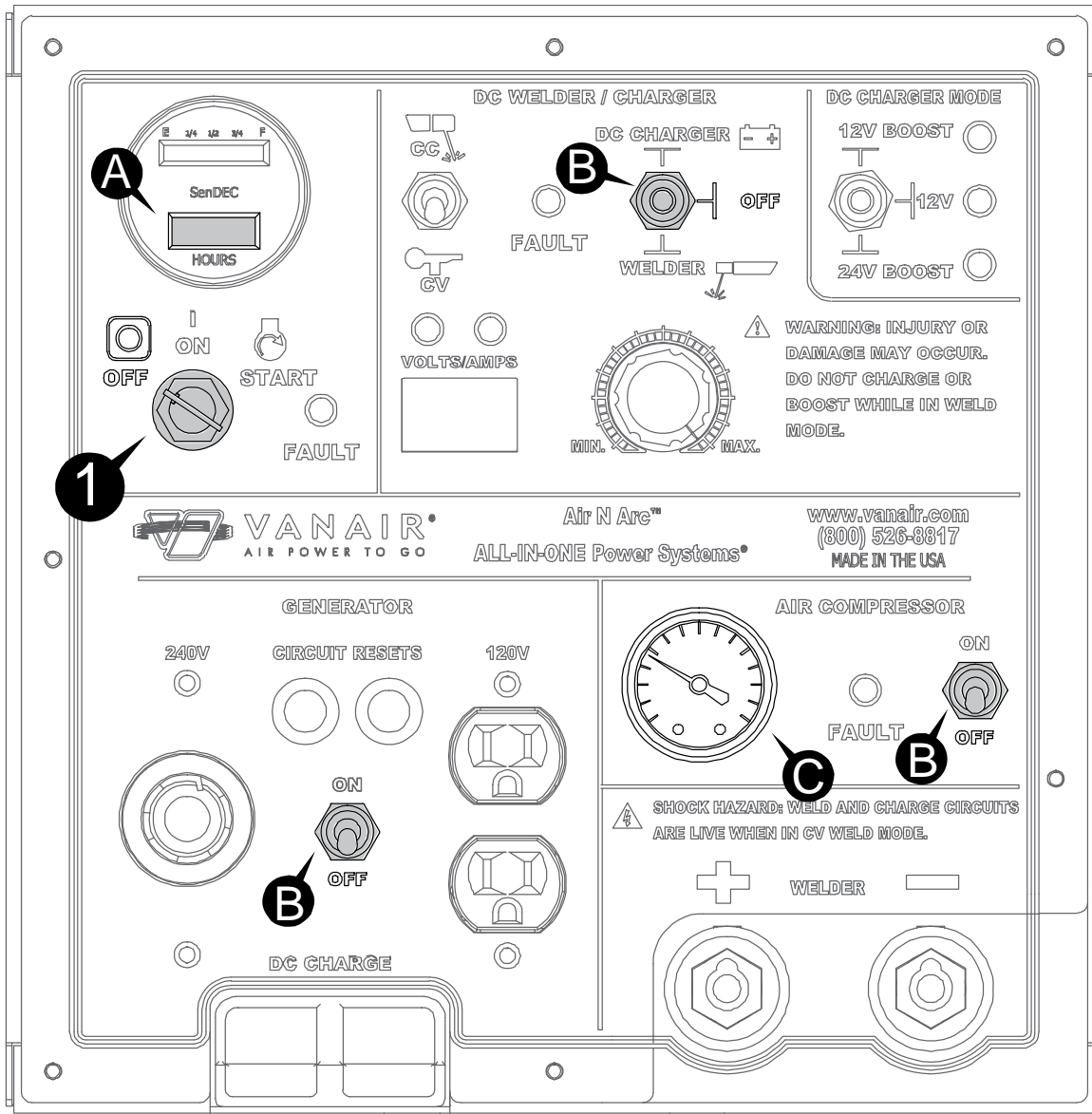

FUNCTION/ACTION		SUSTAINED OR RESPONSE CONDITION	
1	Key OFF	A	Hour meter constantly displays total hours.
		B	Generator, Compressor and Welder switches should all be in the "off" positions.
		C	<b>NOTE:</b> Pressure gauge may or may not show a pressure indication, depending upon compressor status when it was previously shut off.

**NOTE:** No condition lights will be illuminated.



## B.2.2 INSTRUMENT PANEL - KEY TO ON FUNCTION

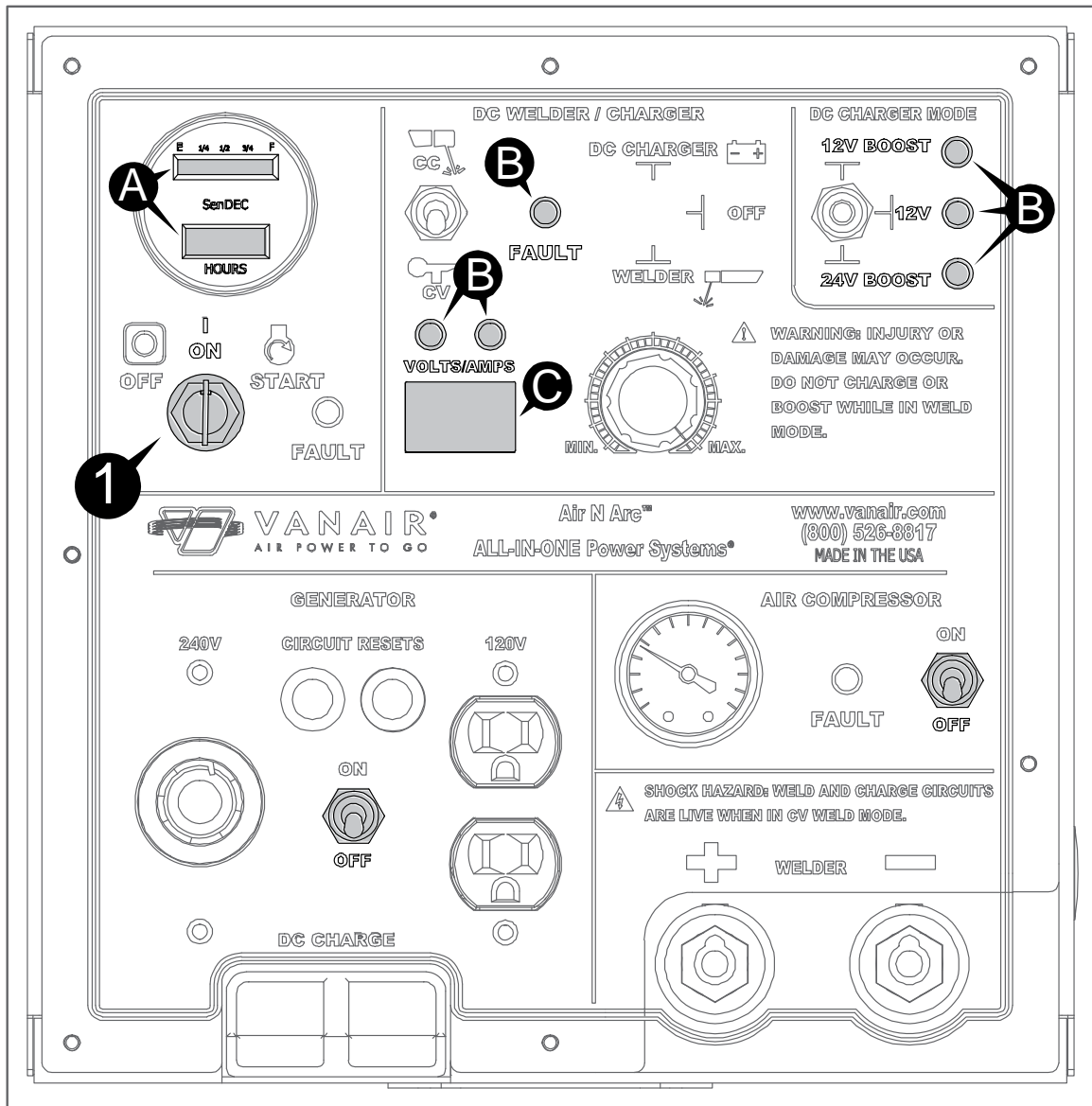

FUNCTION/ACTION		SUSTAINED OR RESPONSE CONDITION	
1	Key to ON	A	Hour meter constantly displays total hours; fuel level meter illuminates.
		B	All welder/generator LEDs (6) will illuminate.
		C	Display for welder/generator amps/volts will reveal a random number, indicating that it is working.

### B.2.3 INSTRUMENT PANEL - KEY TO START FUNCTION

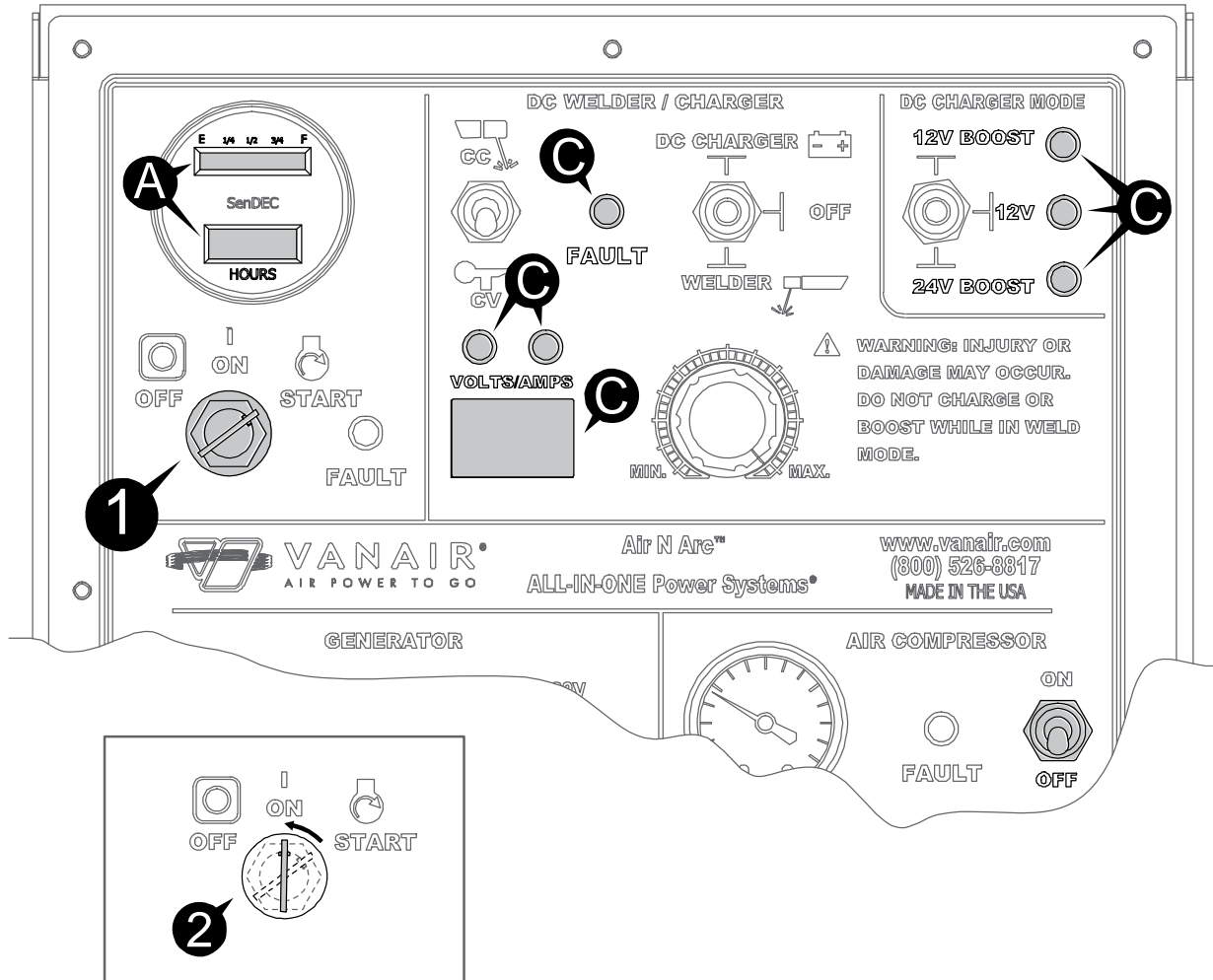

FUNCTION/ACTION		SUSTAINED OR RESPONSE CONDITION	
1	Key to START (Crank)	A	Hour meter remains constantly displaying total hours; fuel level meter continues to display.
		B <sup>I</sup>	The engine cranks and starts up. It will come to an elevated RPM for about three (3) seconds and return to idle.
2	The key automatically reverts back to the ON position when released.	C	All of the weld/generator LEDs and display will remain lit for approximately ten (10) seconds as the module initializes, then will go out.

<sup>I</sup>This particular condition/response's affects are observed elsewhere on the machine and not on the panel.

## B.2.4 INSTRUMENT PANEL - KEY TO RUN (ON) FUNCTION

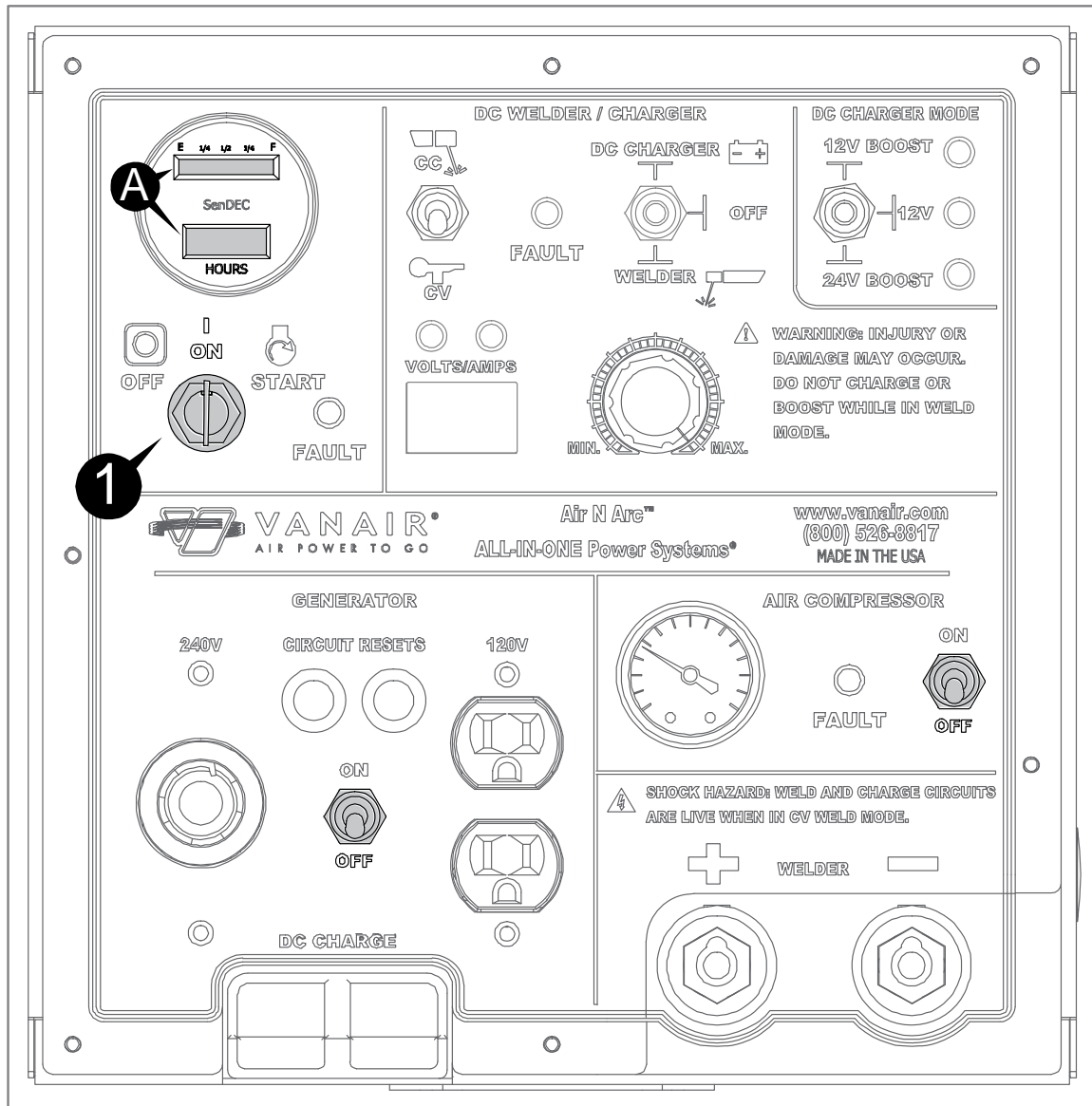

FUNCTION/ACTION		SUSTAINED OR RESPONSE CONDITION	
1	Key to Run (ON) <sup>I</sup>	A	Hour meter constantly displays total hours; fuel level meter continues to display.
		B <sup>II</sup>	Engine runs at low idle speed.

<sup>I</sup>The “On” function for a running system refers to the reverted condition of the ignition switch *after* the engine has completed starting, as per **Section B.2.3.**, #2, and assumes low idle speed.

<sup>II</sup>This particular condition/response’s affects are observed elsewhere on the machine and not on the panel.

### B.3.1 INSTRUMENT PANEL - COMPRESSOR OFF FUNCTION

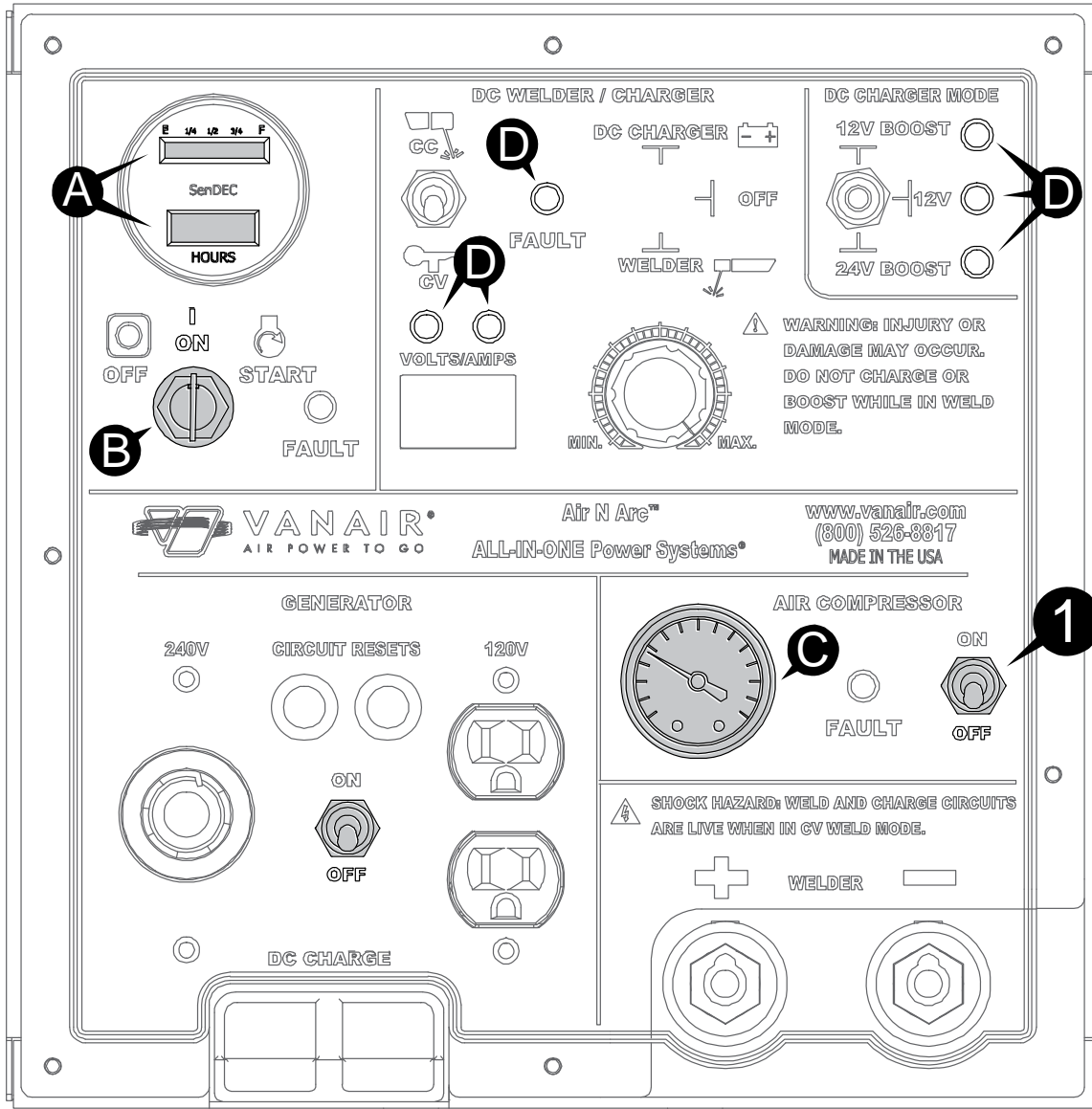

FUNCTION/ACTION		SUSTAINED OR RESPONSE CONDITION	
1	Compressor Switch OFF <sup>I</sup>	A	Hour meter constantly displays total hours; fuel level meter continues to display.
		B	The ignition position is ON, with the engine operating in low idle.
		C	Air pressure gauge may or may not read pressure indication (depending upon compressor status when previously shut off).
		D	No condition LEDs will be on.

<sup>I</sup>The starting condition for operating the compressor begins *after* the engine state is in the pre-existing RUN condition, as explained in **Section B.2.4, Key to Run Function**.

### B.3.2 INSTRUMENT PANEL - COMPRESSOR ON FUNCTION

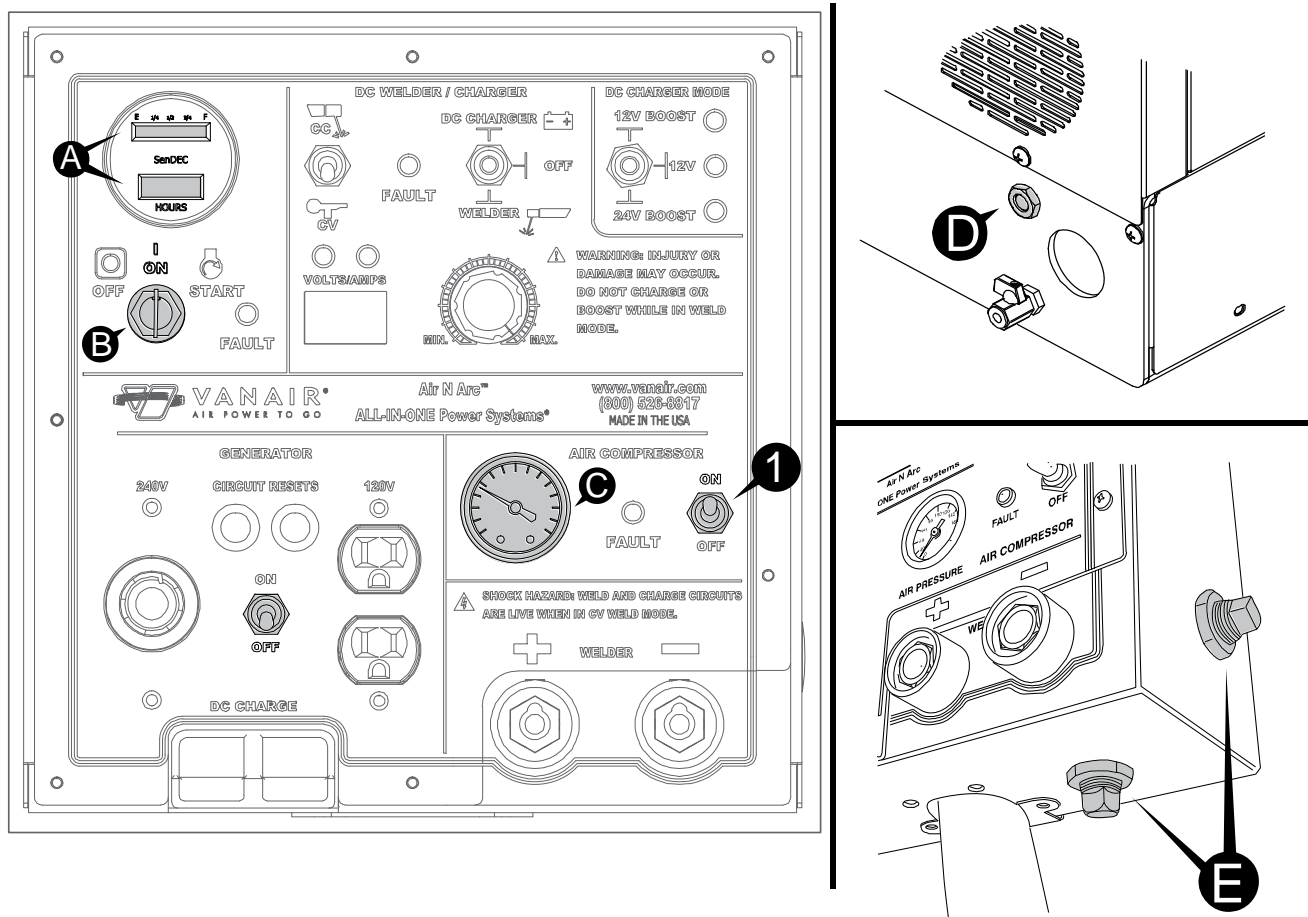

FUNCTION/ACTION		SUSTAINED OR RESPONSE CONDITION	
1	Compressor Switch ON <sup>I</sup>	A	Hour meter constantly displays total hours; fuel level meter continues to display.
		B	The ignition position is ON, with the engine operating in low idle.
		C	(NOTE: Initial air pressure gauge reading depends upon compressor status when previously shut off). Air pressure accumulates in air tank to desired working pressure.
		D <sup>II</sup>	Compressed air will be available at the machine outlet and both outlets on the panel box (E).

<sup>I</sup>The starting condition for operating the compressor begins *after* the engine state is in the pre-existing RUN condition, as explained in **Section B.2.4, Key to Run Function**. As soon as the compressor switch is toggled to the ON position, the engine will accelerate from low idle state to high speed, and remain as long as the compressor switch is in the ON position and air is being used. If air pressure builds to full pressure with no air usage for 2-1/2 minutes, the compressor clutch will disengage, and the engine will return to idle speed.

**NOTE:** No condition lights will be illuminated.

**B.4.1 INSTRUMENT PANEL - WELDER/CHARGER OFF FUNCTION**

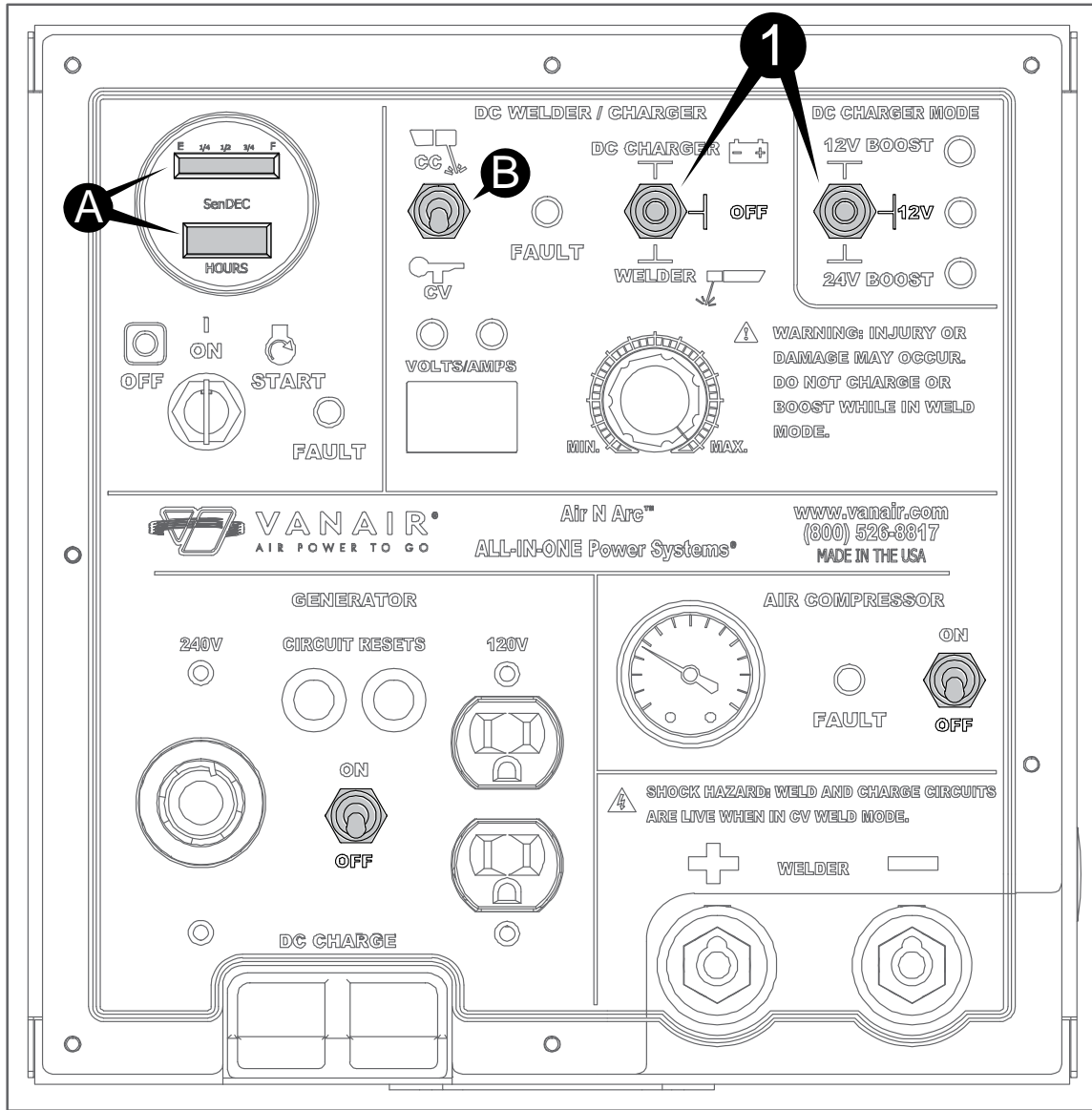

FUNCTION/ACTION		SUSTAINED OR RESPONSE CONDITION	
1	DC Welder/Charger and DC Charger Mode selector switches are in the OFF position <sup>I</sup>	A	Hour meter constantly displays total hours; fuel level meter continues to display.
		B	The CC/CV selector switch will be in either position, but will not affect the display.
<p><sup>I</sup>The starting condition for operating the DC Welder/Charger begins <i>after</i> the engine state is in the pre-existing RUN condition, as explained in <b>Section B.2.4, Key to Run Function</b>. The DC Charger Mode selector switch defaults to the 12V position for its “off” position.</p> <p><b>NOTE:</b> After initiation of the module, no condition lights will be illuminated, and the display will be blank.</p>			

### B.4.2 INSTRUMENT PANEL - DC CHARGER (12V) FUNCTION

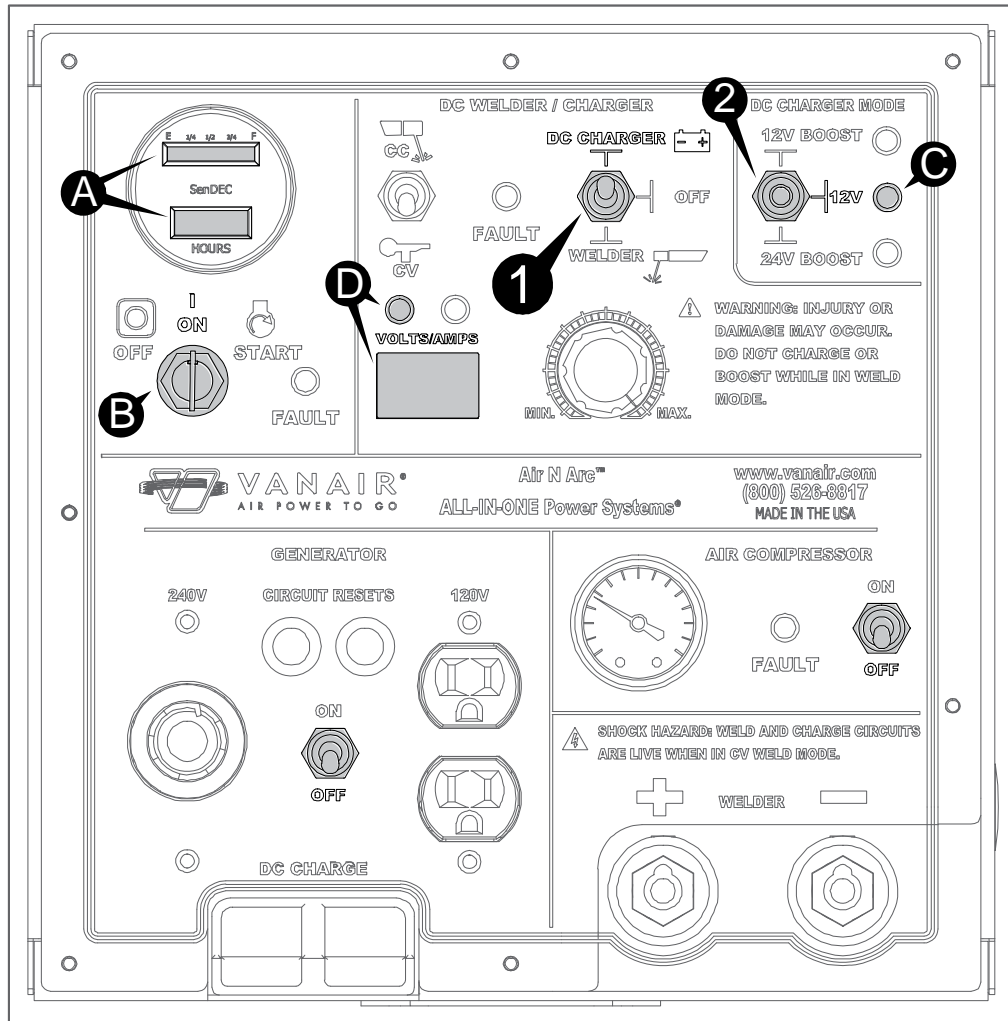

FUNCTION/ACTION		SUSTAINED OR RESPONSE CONDITION	
1	DC Welder/Charger switch is in DC Charger position <sup>I</sup>	A	Hour meter constantly displays total hours; fuel level meter continues to display.
2	DC Charger Mode switch is in the 12V position	B	The ignition position is ON, with the engine operating in low idle.
		C <sup>II</sup>	12V DC Charger Mode LED is lit.
		D	Volt LED will be on; display will indicate the programmed charge voltage for the indicated mode.
<sup>I</sup> When DC Welder/Charger selector switch is in DC Charger position, all <b>Weld</b> mode controls will be ignored including the amperage control.			
<sup>II</sup> The “On” function for a running system refers to the reverted condition of the ignition switch after the engine has completed starting, as per <b>Section B.2.4, Key to Run Function</b> .			
<b>NOTE:</b> All other LEDs will be off.			

### B.4.3 INSTRUMENT PANEL - DC CHARGER (12V BOOST) FUNCTION

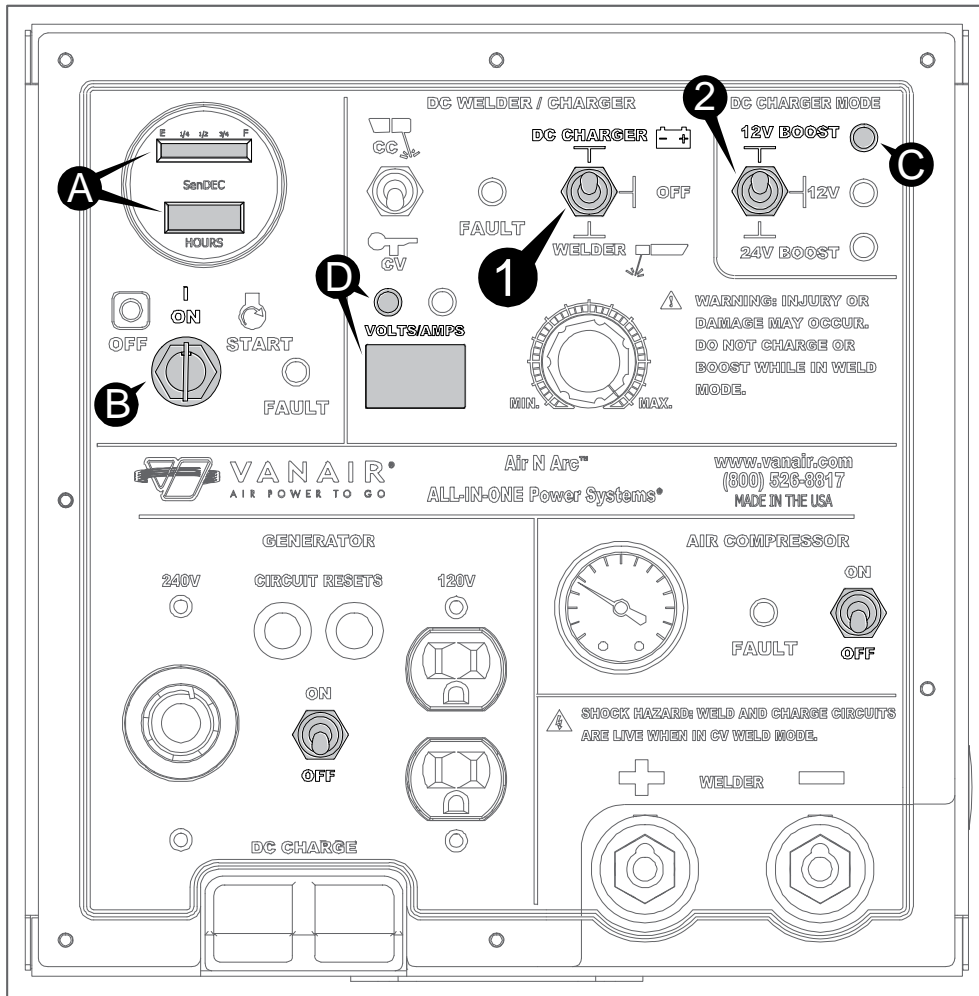

**IMPORTANT**

Boost function is used only for start assist. Sustaining boost can damage equipment.

FUNCTION/ACTION		SUSTAINED OR RESPONSE CONDITION	
1	DC Welder/Charger switch is in DC Charger position <sup>I</sup>	A	Hour meter constantly displays total hours; fuel level meter continues to display.
2	DC Charger Mode switch is in the 12V Boost position	B	The ignition position is ON, with the engine operating in low idle.
		C <sup>II</sup>	12V Boost DC Charger Mode LED is lit.
		D	Volt LED will be on; display will indicate the programmed charge voltage for the indicated mode.
<sup>I</sup> When DC Welder/Charger selector switch is in DC Charger position, all <b>Weld</b> mode controls will be ignored including the amperage control.			
<sup>II</sup> The “On” function for a running system refers to the reverted condition of the ignition switch after the engine has completed starting, as per <b>Section B.2.4, Key to Run Function</b> .			
<b>NOTE:</b> All other LEDs will be off.			



### B.4.4 INSTRUMENT PANEL - DC CHARGER (24V BOOST) FUNCTION

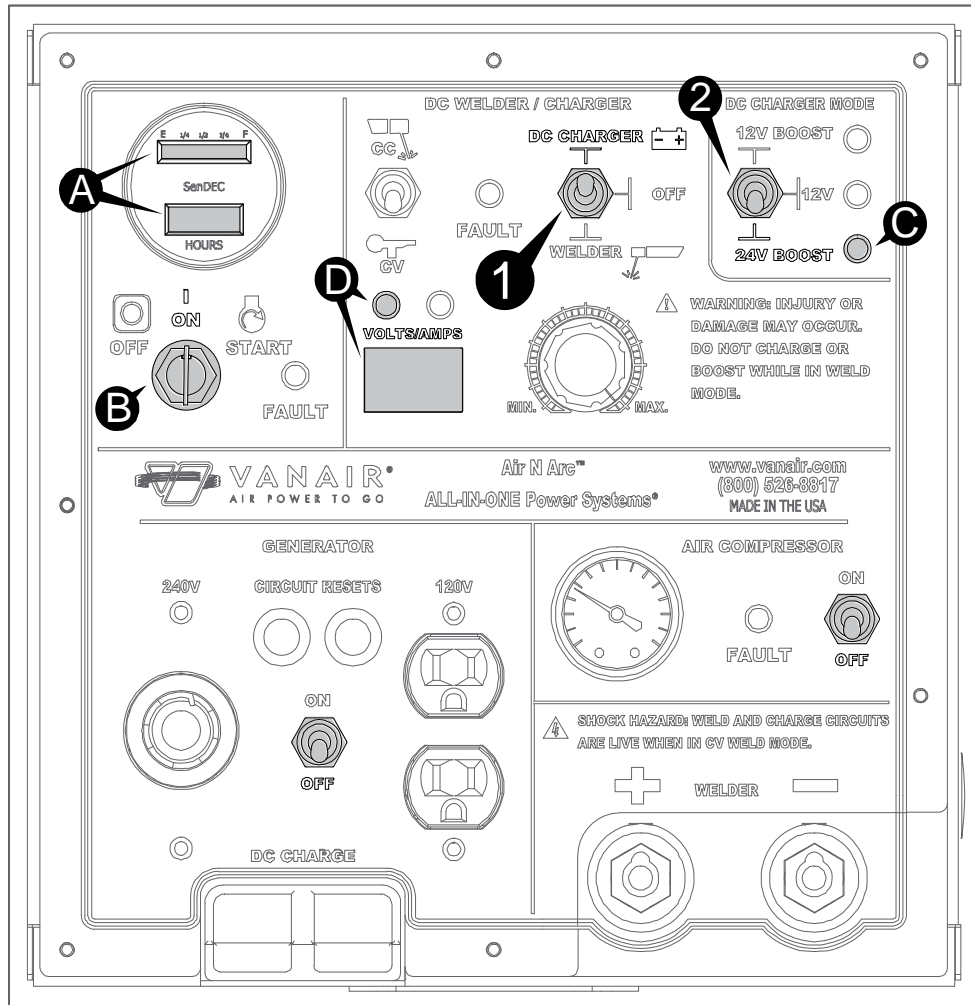

**IMPORTANT**

Boost function is used only for start assist. Sustaining boost can damage equipment.

FUNCTION/ACTION		SUSTAINED OR RESPONSE CONDITION	
1	DC Welder/Charger switch is in DC Charger position <sup>I</sup>	A	Hour meter constantly displays total hours; fuel level meter continues to display.
2	DC Charger Mode switch is in the 24V Boost position	B	The ignition position is ON, with the engine operating in low idle.
		C <sup>II</sup>	24V Boost DC Charger Mode LED is lit.
		D	Volt LED will be on; display will indicate the programmed charge voltage for the indicated mode.
<sup>I</sup> When DC Welder/Charger selector switch is in DC Charger position, all <b>Weld</b> mode controls will be ignored including the amperage control.			
<sup>II</sup> The "On" function for a running system refers to the reverted condition of the ignition switch after the engine has completed starting, as per <b>Section B.2.4, Key to Run Function</b> .			
<b>NOTE:</b> All other LEDs will be off.			

### B.4.5 INSTRUMENT PANEL - WELDER CC FUNCTION

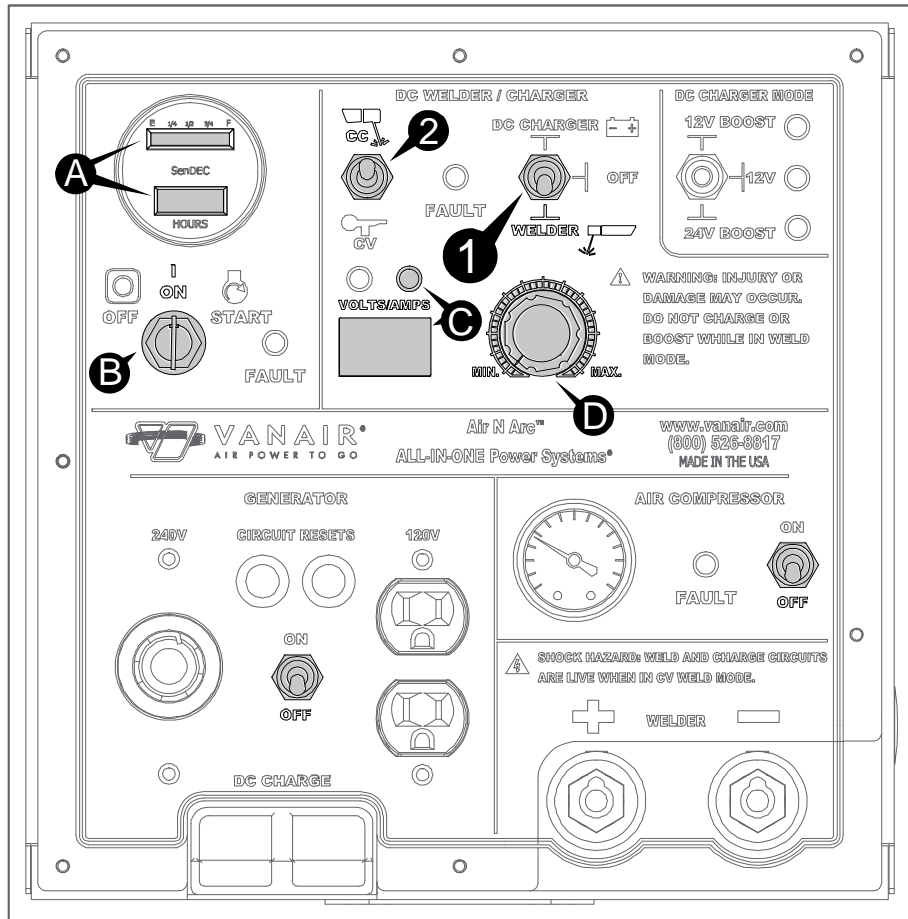

FUNCTION/ACTION		SUSTAINED OR RESPONSE CONDITION	
1	DC Welder/Charger switch is in Welder position <sup>I</sup>	A	Hour meter constantly displays total hours; fuel level meter continues to display.
2	Switch for Constant Current/Constant Voltage is in the CC position	B <sup>II</sup>	The ignition position is ON, with the engine operating in low idle.
		C	Amp LED is on; display briefly shows amperage setting requested from potentiometer (D <sup>III</sup> ), then will show the amperage currently being used at the attached welder leads.

<sup>I</sup>When DC Welder/Charger selector switch is in **Welder** position, all **DC Charger** mode controls will be ignored, and the LEDs will be out.

<sup>II</sup>The “On” function for a running system refers to the reverted condition of the ignition switch after the engine has completed starting, as per **Section B.2.4, Key to Run Function**.

<sup>III</sup>Each time an adjustment is made the display will show the setting briefly for approximately three (3) seconds, and then return to the usage display.

**NOTE:** All other LEDs will be off.

## B.4.6 INSTRUMENT PANEL - WELDER CV FUNCTION

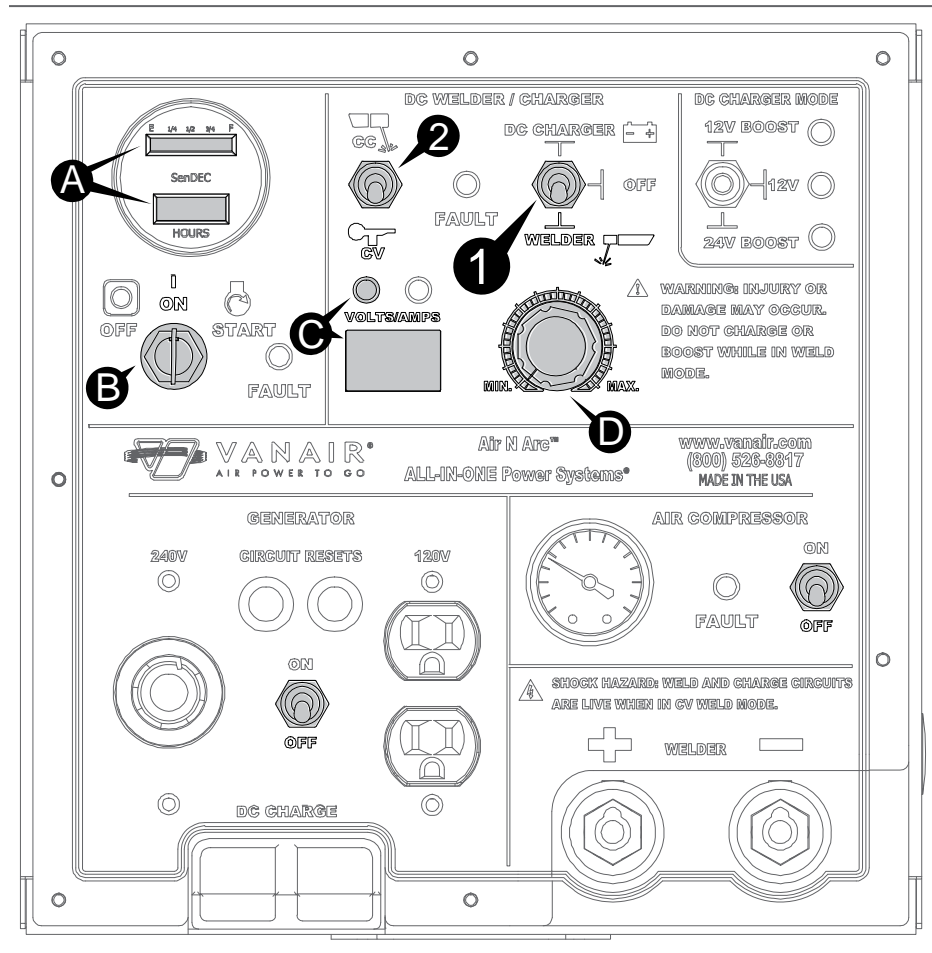

**WARNING**  
Welder and DCcircuit charger are live.

FUNCTION/ACTION		SUSTAINED OR RESPONSE CONDITION	
1	DC Welder/Charger switch is in Welder position <sup>I</sup>	A	Hour meter constantly displays total hours; fuel level meter continues to display.
2	Switch for Constant Current/Constant Voltage is in the CV position	B <sup>II</sup>	The ignition position is ON, with the engine operating in low idle.
		C	Volt LED is on; display briefly shows voltage setting requested from potentiometer (D <sup>III</sup> ), then will show the voltage currently being used at the attached welder leads.
<sup>I</sup> When DC Welder/Charger selector switch is in <b>Welder</b> position, all <b>DC Charger</b> mode controls will be ignored, and the LEDs will be off.			
<sup>II</sup> The “On” function for a running system refers to the reverted condition of the ignition switch after the engine has completed starting, as per <b>Section B.2.4, Key to Run Function</b> .			
<sup>III</sup> Each time an adjustment is made the display will show the setting briefly for approximately three (3) seconds, and then return to the usage display.			
<b>NOTE:</b> All other LEDs will be off.			

### B.5.1 INSTRUMENT PANEL - GENERATOR OFF FUNCTION

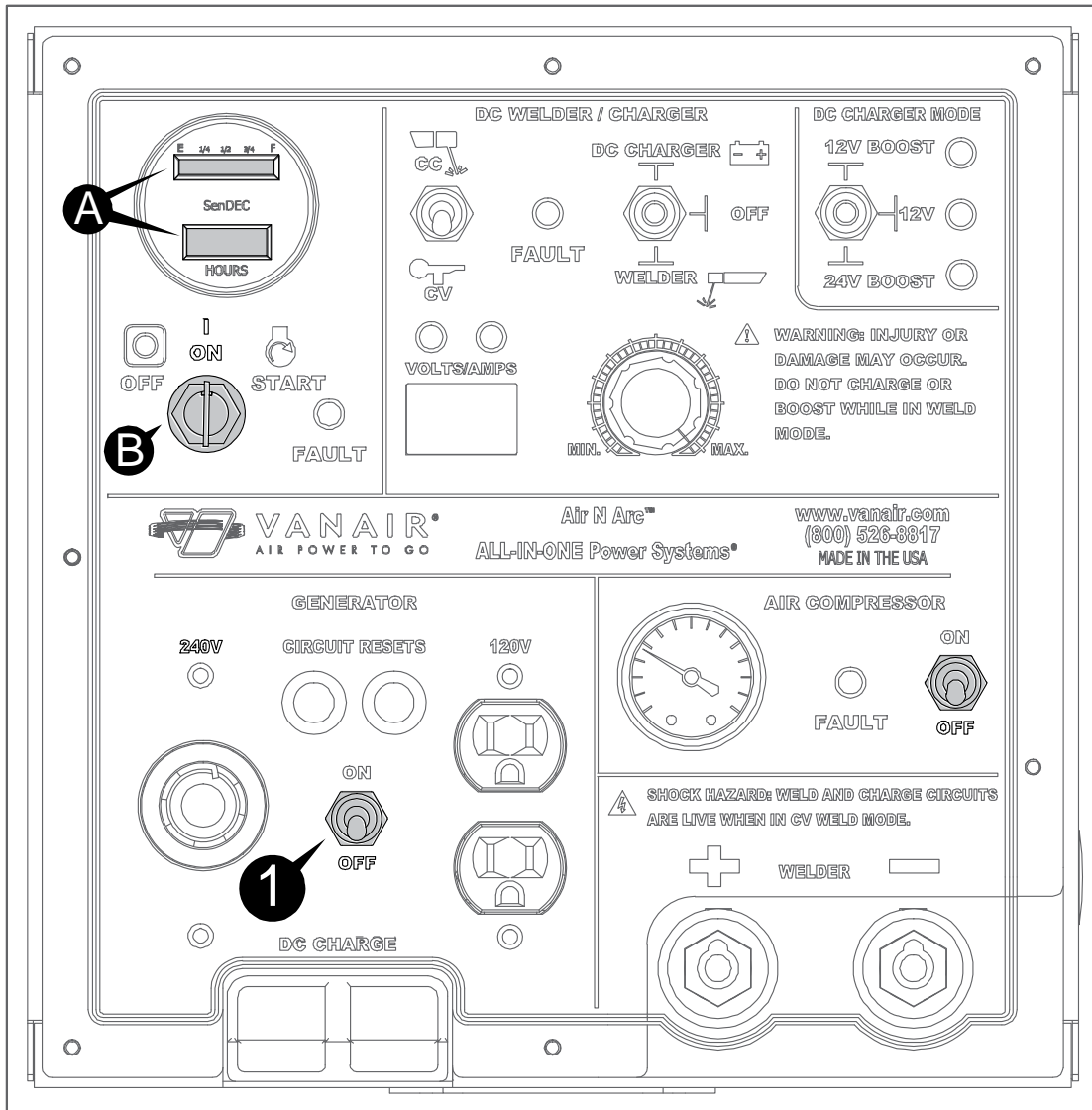

FUNCTION/ACTION		SUSTAINED OR RESPONSE CONDITION	
1	Generator switch is in OFF position <sup>I</sup>	A	Hour meter constantly displays total hours; fuel level meter continues to display.
		B <sup>I</sup>	The ignition position is ON, with the engine operating in low idle.
<p><sup>I</sup>The “On” function for a running system refers to the reverted condition of the ignition switch after the engine has completed starting, as per <b>Section B.2.4, Key to Run Function</b>.</p> <p><b>NOTE:</b> No power will be available at either the 240V or 120V power receptacles. No condition LEDs will be on.</p>			

## B.5.2 INSTRUMENT PANEL - GENERATOR ON FUNCTION

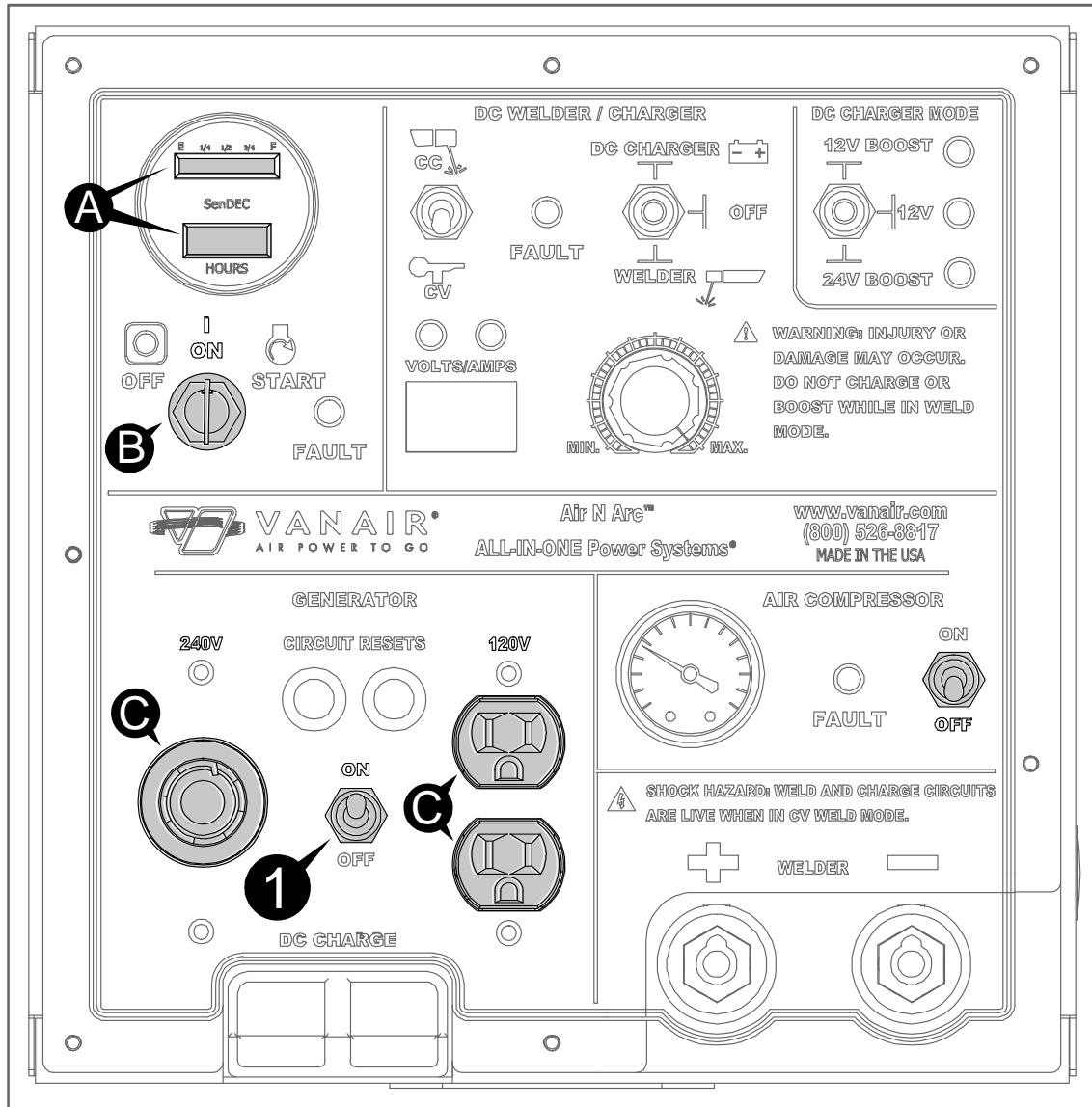

FUNCTION/ACTION		SUSTAINED OR RESPONSE CONDITION	
1	Generator switch is in ON position <sup>I</sup>	A	Hour meter constantly displays total hours; fuel level meter continues to display.
		B <sup>I</sup>	The ignition position is ON, with the engine operating in high idle.
		C	Power is available at both the 120V and 240V receptacles.
<sup>I</sup> The engine will accelerate and remain at high speed as long as the generator switch is in the ON position.			
<b>NOTE:</b> No condition LEDs will be on.			

**BLANK PAGE**

# APPENDIX C: MAINTENANCE AND SERVICE LOG

---

---

## C.1 GENERAL DESCRIPTION

The maintenance and service log given in this appendix can be used to track and keep a record of the maintenance intervals of the machine, as well as any non-routine repairs or changes made, throughout the productive life of the machine package.

Keeping such a record is extremely beneficial when considering a solution to any troubleshooting problem that might occur. For additional assistance in setting up a routine and orderly schedule to track machine maintenance and repair, refer to **Section 6, Maintenance**, and particularly **Section 6.3, Maintenance Schedule Table**.

For procedure on ordering parts, consult **Section 9, Parts Ordering Procedure, Table 9A - Recommended Spare Parts List**, and **Appendix A, Section A.5, Air N Arc 300 Series All-In-One Power System Available Options List**.

If a part needs to be replaced, but is not listed in any of the above sections, it can readily be identified visually by scanning through the various parts list sections. The various parts list sections identify each part by its individual part number, which in turn can be used to order any part that needs to be replaced.

*C.2 MAINTENANCE AND SERVICE LOG*

Date of Purchase: \_\_\_\_\_

**BREAK-IN PERIOD SERVICE POINTS**

Date Completed: \_\_\_\_\_

**50 HOURS OR TWO MONTHS SERVICE POINTS**

Dates Completed: \_\_\_\_\_

\_\_\_\_\_

\_\_\_\_\_

\_\_\_\_\_

\_\_\_\_\_

\_\_\_\_\_

\_\_\_\_\_

\_\_\_\_\_

\_\_\_\_\_

\_\_\_\_\_

\_\_\_\_\_

\_\_\_\_\_

\_\_\_\_\_

**100 HOURS OR FOUR MONTHS SERVICE POINTS**

Dates Completed & Parts Replaced: \_\_\_\_\_

\_\_\_\_\_

\_\_\_\_\_

\_\_\_\_\_

\_\_\_\_\_

\_\_\_\_\_

\_\_\_\_\_

\_\_\_\_\_

\_\_\_\_\_

\_\_\_\_\_

\_\_\_\_\_

\_\_\_\_\_

**200 HOURS OR EIGHT MONTHS SERVICE POINTS**

Dates Completed & Parts Replaced: \_\_\_\_\_

\_\_\_\_\_

\_\_\_\_\_

\_\_\_\_\_

\_\_\_\_\_

\_\_\_\_\_

\_\_\_\_\_

\_\_\_\_\_

\_\_\_\_\_

\_\_\_\_\_

**300 HOURS OR ONE YEAR SERVICE POINTS**

Dates Completed & Parts Replaced: \_\_\_\_\_

\_\_\_\_\_

\_\_\_\_\_

\_\_\_\_\_

\_\_\_\_\_

\_\_\_\_\_

\_\_\_\_\_

**600 HOURS OR TWO YEARS SERVICE POINTS**

Dates Completed & Parts Replaced: \_\_\_\_\_

\_\_\_\_\_

\_\_\_\_\_

\_\_\_\_\_

\_\_\_\_\_

\_\_\_\_\_

\_\_\_\_\_

\_\_\_\_\_

\_\_\_\_\_

\_\_\_\_\_

\_\_\_\_\_

\_\_\_\_\_

**OTHER SERVICE NOTES**

\_\_\_\_\_

\_\_\_\_\_

\_\_\_\_\_



*C.2 MAINTENANCE AND SERVICE LOG*

Date of Purchase: \_\_\_\_\_

**BREAK-IN PERIOD SERVICE POINTS**

Date Completed: \_\_\_\_\_

**50 HOURS OR TWO MONTHS SERVICE POINTS**

Dates Completed: \_\_\_\_\_

\_\_\_\_\_

\_\_\_\_\_

\_\_\_\_\_

\_\_\_\_\_

\_\_\_\_\_

\_\_\_\_\_

\_\_\_\_\_

\_\_\_\_\_

\_\_\_\_\_

\_\_\_\_\_

\_\_\_\_\_

\_\_\_\_\_

**100 HOURS OR FOUR MONTHS SERVICE POINTS**

Dates Completed & Parts Replaced: \_\_\_\_\_

\_\_\_\_\_

\_\_\_\_\_

\_\_\_\_\_

\_\_\_\_\_

\_\_\_\_\_

\_\_\_\_\_

\_\_\_\_\_

\_\_\_\_\_

\_\_\_\_\_

\_\_\_\_\_

\_\_\_\_\_

**200 HOURS OR EIGHT MONTHS SERVICE POINTS**

Dates Completed & Parts Replaced: \_\_\_\_\_

\_\_\_\_\_

\_\_\_\_\_

\_\_\_\_\_

\_\_\_\_\_

\_\_\_\_\_

\_\_\_\_\_

\_\_\_\_\_

\_\_\_\_\_

\_\_\_\_\_

\_\_\_\_\_

\_\_\_\_\_

\_\_\_\_\_

\_\_\_\_\_

\_\_\_\_\_

\_\_\_\_\_

\_\_\_\_\_

\_\_\_\_\_

\_\_\_\_\_

\_\_\_\_\_

\_\_\_\_\_

\_\_\_\_\_

\_\_\_\_\_

\_\_\_\_\_

\_\_\_\_\_

\_\_\_\_\_

\_\_\_\_\_

\_\_\_\_\_

\_\_\_\_\_

\_\_\_\_\_

\_\_\_\_\_

\_\_\_\_\_

\_\_\_\_\_

\_\_\_\_\_

\_\_\_\_\_

\_\_\_\_\_

**OTHER SERVICE NOTES**

\_\_\_\_\_

\_\_\_\_\_

\_\_\_\_\_

\_\_\_\_\_

**BLANK PAGE**

**BLANK PAGE**



# VANAIR®

AIR POWER TO GO™

**Vanair Manufacturing, Inc.**

**10896 West 300 North**

**Michigan City, IN 46360**

**Phone: (219) 879-5100**

**(800) 526-8817**

**Service Fax: (219) 879-5335**

**Parts Fax: (219) 879-5340**

**Sales Fax: (219) 879-5800**

**[www.vanair.com](http://www.vanair.com)**

Printed in the U.S.A.

Specifications Subject to Change  
Without Prior Notice