

# AIR N ARC<sup>®</sup>

BY VANAIR<sup>®</sup>

ALL-IN-ONE Power Systems<sup>®</sup>

## AIR N ARC<sup>®</sup> 150 (19HP)

### ALL-IN-ONE POWER SYSTEMS<sup>®</sup>

WELDER • GENERATOR • AIR COMPRESSOR • BATTERY BOOSTER  
OPERATION MANUAL & PARTS LIST

#### NOTE

This publication contains the latest information available at the time of preparation. Every effort has been made to ensure accuracy.

Vanair Manufacturing, Inc. reserves the right to make design change modifications or improvements without prior notification.

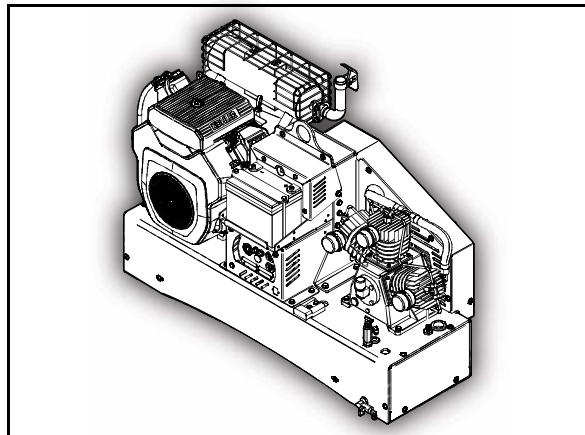

Read this manual before installing, operating or servicing this equipment. Failure to comply with the operation and maintenance instructions in this manual WILL VOID THE EQUIPMENT WARRANTY.

#### NOTE

Use only Vanair Vanguard™ Premium Synthetic Oil and Genuine Vanair Parts. Inspect and replace damaged components before operation. Substituting non-Vanguard™ Oil or non-genuine Vanair filter components WILL VOID THE COMPRESSOR WARRANTY!

#### Vanair Manufacturing, Inc.

10896 West 300 North  
Michigan City, IN 46360

Phone: (219) 879-5100  
(800) 526-8817

Service (844) VANSERV  
[844-826-7378]

Service Fax: (219) 879-5335

Parts Fax: (219) 879-5340

Sales Fax: (219) 879-5800

[www.vanair.com](http://www.vanair.com)

#### NOTE

Making unauthorized modifications to the system components WILL VOID THE WARRANTY!

Always inform Vanair Manufacturing, Inc., before beginning any changes to the Air N Arc system.

**KEEP THE MANUAL  
WITH THE VEHICLE**

©2015 Vanair Manufacturing, Inc.  
All rights reserved



**VANAIR<sup>®</sup>**  
POWER TO GO™

P/N: 090043-OP\_r0

Effective Date:  
March-2015

**AIR N ARC®  
ALL-IN-ONE POWER-SYSTEMS®**

**RELIANT™ SERIES**

**POWERFLEX™ SERIES**

**PRO SERIES**

**CONTRACTOR SERIES**

**VIPER™ SERIES**

**FST™ SERIES**

**(844) VAN - SERV**

**SERVICE@VANAIR.COM**

**PARTS@VANAIR.COM**

**10896 W. 300 N.  
MICHIGAN CITY, IN 46360**

**(800) 526-8817**

**VANAIR.COM**

**EFFECTIVE: JAN 8, 2016**

090088\_r1

# VANAIR VANTAGE WARRANTY

This limited warranty supersedes all previous Vanair warranties and is exclusive with no other guarantees or warranties expressed or implied.

**LIMITED WARRANTY**—Subject to the expressed terms and conditions set forth below, Vanair Mfg., Inc. ("Vanair"), of Michigan City, Indiana (USA), warrants to the original retail purchaser of new Vanair equipment that such equipment is free from defects in materials and workmanship when shipped by Vanair.

For warranty claims received by Vanair within the applicable warranty periods described below, Vanair will repair or replace any warranted equipment, parts or components that fail due to defects in material or workmanship or refund the purchase price for the equipment, at Vanair's discretion. Vanair is not responsible for time or labor to gain access to the machine to perform work. **WARRANTY WILL BE VOID IF GENUINE VANAIR PARTS AND FLUIDS ARE NOT USED.**

Vanair must be notified in writing within thirty (30) days of any such defect or failure. No warranty work or returns without prior authorization is allowed. Vanair will provide instructions on the warranty claim procedures to be followed.

Warranty will commence upon receipt of the Warranty Registration Card. If the Warranty Registration Card is not received within six (6) months of shipment from Vanair, the warranty commencement date shall be thirty (30) days from the date of shipment from Vanair. Records of warranty adherence are the responsibility of the end user.

1. Lifetime Warranty Parts – 3 Years Labor
  - Rotary Screw Air Compressor Air End
2. 6 Years Parts – 3 Years Labor
  - Vanair Super Capacitor (VSC)
3. 3 Years Parts – 1 Year Labor
  - Reciprocating Compressor Air End
  - Generators
  - Welders
4. 2 Years Parts – 1 Year Labor
  - Hydraulic Motors
  - Hydraulic Pumps
5. 1 Year Parts – 1 Year Labor
  - All electronics including, but not limited to:
    - (i) I/O Boards
    - (ii) Modules
    - (iii) Panel Boxes
    - (iv) Instrumentation
    - (v) Clutches
    - (vi) Solenoids
    - (vii) Running Gear/Trailers
    - (viii) Compressor/Hydraulic Coolers, including Fan and Radiator Core

This Limited Warranty shall not apply to:

1. Consumable components, such as shaft seals, valves, belts, filters, capacitors, contactors, relays, brushes or parts that fail due to normal wear and use.
2. Items furnished by Vanair, but manufactured by others, such as engines and trade accessories (these items are covered by the manufacturer's warranty, if any).
3. Equipment that has been modified by any party other than Vanair or equipment which has not been used and maintained in accordance with Vanair's specifications.
4. Equipment which has been improperly installed and/or improperly operated, based upon Vanair's specifications for the equipment or industry standards.
5. Equipment installed by non-authorized or third party personnel.

Vanair products are intended for purchase and use by commercial/industrial users and persons trained and experienced in the use and maintenance of industrial equipment.

In the event of a warranty claim covered by this Limited Warranty, the exclusive remedies shall be, at Vanair's sole discretion: (i) repair; or (ii) replacement; (iii) where authorized in writing by Vanair in appropriate cases, the reasonable cost of repair or replacement at an authorized Vanair service facility; or (iv) payment of (or credit for) the purchase price (less reasonable depreciation based upon actual use) upon return of the equipment at the warranty claimant's risk and expense. Vanair will pay standard ground freight for any warranty item shipped to and from Vanair or (Vanair designated facility) within the first year of the applicable warranty period. Any additional expedited freight cost is the responsibility of the purchaser.

TO THE GREAT EXTENT PERMITTED BY APPLICABLE LAW, THE REMEDIES PROVIDED HEREIN ARE THE SOLE AND EXCLUSIVE REMEDIES APPLICABLE TO THE VANAIR EQUIPMENT. IN NO EVENT SHALL VANAIR BECOME LIABLE FOR DIRECT, INDIRECT, SPECIAL, PUNITIVE, INCIDENTAL OR CONSEQUENTIAL DAMAGES (INCLUDING LOSS OF PROFIT OR LOST BUSINESS OPPORTUNITY), WHETHER BASED ON CONTRACT, TORT OR ANY OTHER LEGAL THEORY. IN NO EVENT SHALL VANAIR BECOME OBLIGATED TO PAY MORE ON ANY WARRANTY CLAIM THAN THE PURCHASE PRICE ACTUALLY PAID BY THE ORIGINAL RETAIL PURCHASER.

THIS LIMITED WARRANTY IS MADE IN LIEU OF ALL OTHER WARRANTIES, EXPRESS OR IMPLIED, INCLUDING THE WARRANTIES OF MERCHANTABILITY AND/OR FITNESS FOR A PARTICULAR PURPOSE, OR ANY OTHER WARRANTY OR GUARANTY ARISING BY OPERATION OF LAW. ANY WARRANTY NOT EXPRESSLY PROVIDED HEREIN, IMPLIED WARRANTY, GUARANTY AND ANY REPRESENTATION REGARDING THE PERFORMANCE OF THE EQUIPMENT, AND ANY REMEDY FOR BREACH OF CONTRACT, IN TORT, OR ANY OTHER LEGAL THEORY WHICH, BUT FOR THIS PROVISION, MIGHT ARISE BY IMPLICATION, OPERATION OF LAW, CUSTOM OF TRADE, OR COURSE OF DEALING ARE EXCLUDED AND DISCLAIMED BY VANAIR.

Some states in the United States of America do not allow limitations of how long an implied warranty lasts, or the exclusion of incidental, indirect, special or consequential damages, and as such, the above limitations and exclusions may not apply to you. This warranty provides specific legal rights. Other rights may be available to you, but may vary from state to state.

In Canada, legislation in some provinces provides for certain additional warranties or remedies other than as stated herein, and to the extent that they may not be saved, the limitations and exclusions set out forth above may not apply. This Limited Warranty provides specific legal rights, and other rights may be available, but may vary from province to province.



**VANAIR®**  
MOBILE POWER SOLUTIONS™

# TABLE OF CONTENTS

**WARRANTY ..... BEHIND COVER**

**TABLE OF CONTENTS..... I**

**WARRANTY CLAIM PROCEDURE..... VII**

CLAIMS PROCESS FOR WARRANTED PARTS ..... VII  
 PROCEDURE ..... VII

**SECTION 1: SAFETY ..... 1**

1.1 GENERAL INFORMATION ..... 1

1.2 DANGERS, WARNINGS, CAUTIONS, AND NOTES ..... 1

1.3 INTERNATIONAL SAFETY SYMBOL ..... 1

1.4 ARC WELDING HAZARDS ..... 1

    1.4.1 ELECTRICAL SHOCK CAN KILL ..... 1

    1.4.2 FUMES AND GASES CAN BE HAZARDOUS ..... 2

    1.4.3 BUILD UP OF GAS CAN INJURE OR KILL ..... 3

    1.4.4 ENCLOSED SPACES CAN CAUSE A BUILD-UP OF NOXIOUS FUMES AND OVERHEATING ..... 3

    1.4.5 ARC RAYS CAN BURN EYES AND SKIN ..... 3

    1.4.6 WELDING CAN CAUSE FIRE AND EXPLOSION ..... 3

    1.4.7 FLYING METAL CAN INJURE EYES ..... 4

    1.4.8 HOT PARTS CAN CAUSE SEVERE BURNS ..... 4

    1.4.9 NOISE CAN DAMAGE HEARING ..... 4

    1.4.10 MAGNETIC FIELDS CAN AFFECT PACEMAKERS ..... 4

    1.4.11 CYLINDERS CAN EXPLODE IF DAMAGED ..... 4

1.5 ENGINE HAZARDS ..... 5

    1.5.1 BATTERY EXPLOSION CAN BLIND ..... 5

    1.5.2 FUEL CAN CAUSE FIRE OR EXPLOSION ..... 5

    1.5.3 MOVING PARTS CAN CAUSE INJURY ..... 5

    1.5.4 HOT PARTS CAN CAUSE SEVERE BURNS ..... 6

    1.5.5 ENGINE EXHAUST GASES CAN KILL ..... 6

    1.5.6 ENCLOSED SPACES CAN CAUSE A BUILD-UP OF NOXIOUS FUMES AND OVERHEATING ..... 6

    1.5.7 BATTERY ACID CAN BURN SKIN AND EYES ..... 6

**Continued on next page...**

# SECTION 1: SAFETY (CONTINUED)

- 1.5.8 ENGINE HEAT CAN CAUSE FIRE ..... 6
- 1.5.9 EXHAUST SPARKS CAN CAUSE FIRE ..... 6
- 1.6 COMPRESSED AIR HAZARDS ..... 6
  - 1.6.1 BREATHING COMPRESSED AIR CAN CAUSE SERIOUS INJURY OR DEATH ..... 6
  - 1.6.2 ENCLOSED SPACES CAN CAUSE A BUILD-UP OF NOXIOUS FUMES AND OVERHEATING ..... 6
  - 1.6.3 COMPRESSED AIR CAN CAUSE INJURY ..... 7
  - 1.6.4 TRAPPED AIR PRESSURE AND WHIPPING HOSES CAN CAUSE INJURY ..... 7
  - 1.6.5 HOT METAL FROM AIR ARC CUTTING AND GOUGING CAN CAUSE FIRE OR EXPLOSION ..... 7
  - 1.6.6 HOT PARTS CAN CAUSE SEVERE BURNS ..... 7
  - 1.6.7 READ INSTRUCTIONS ..... 7
- 1.7 ADDITIONAL SYMBOLS FOR INSTALLATION, OPERATION AND MAINTENANCE ..... 7
  - 1.7.1 FALLING UNIT CAN CAUSE INJURY ..... 7
  - 1.7.2 OVERHEATING CAN DAMAGE MOTORS ..... 7
  - 1.7.3 FLYING SPARKS CAN CAUSE INJURY ..... 7
  - 1.7.4 OVERUSE CAN CAUSE OVERHEATING ..... 8
  - 1.7.5 ENCLOSED SPACES CAN CAUSE A BUILD-UP OF NOXIOUS FUMES AND OVERHEATING ..... 8
  - 1.7.6 TILTING OF TRAILER CAN CAUSE INJURY ..... 8
  - 1.7.7 READ INSTRUCTIONS ..... 8
  - 1.7.8 H.F. RADIATION CAN CAUSE INTERFERENCE ..... 8
  - 1.7.9 ARC WELDING CAN CAUSE INTERFERENCE ..... 8
- 1.8 CALIFORNIA PROPOSITION 65 WARNINGS ..... 9
- 1.9 PRINCIPAL SAFETY STANDARDS ..... 9
- 1.10 EMF INFORMATION ..... 9
- 1.11 SAFETY DECALS ..... 10
- 1.12 DISPOSING OF MACHINE FLUIDS ..... 10

# SECTION 2: SPECIFICATIONS ..... 11

- TABLE 2A: WELDER, GENERATOR AND ENGINE ..... 11
- TABLE 2B: AIR COMPRESSOR ..... 11
- TABLE 2C: UNIT WEIGHT AND DIMENSIONS ..... 12

# SECTION 3: INSTALLATION ..... 13

- 3.1 MACHINE PACKAGE RECEIPT/INSPECTION ..... 13
- 3.2 MACHINE PACKAGE PREP ..... 13
- 3.3 SERVICE BODY PREP ..... 14
- 3.4 STABILIZING PRECAUTIONS FOR MACHINE MOUNTING ..... 14

**Continued on next page...**

## **SECTION 3: INSTALLATION (CONTINUED)**

3.5	MACHINE PACKAGE MOUNTING .....	14
3.6	CONNECTING THE FUEL SYSTEM (IF REQUIRED) .....	14
3.7	INSTALLING THE REMOTE CONTROL PANEL .....	15
3.8	INSTALLING (OPTIONAL) REMOTE AIR TANK .....	15

## **SECTION 4: OPERATION..... 17**

4.1	GENERAL INFORMATION .....	17
4.2	ENGINE START-UP AND SHUTDOWN PROCEDURE .....	17
4.2.1	ENGINE START-UP .....	18
4.2.2	ENGINE SHUTDOWN.....	18
4.3	ENGINE THROTTLE CONTROL FUNCTIONS .....	20
	TABLE 4A: ENGINE THROTTLE CONTROL FUNCTION CONDITIONS .....	20
4.4	OPERATING THE WELDER .....	21
	TABLE 4B: ELECTRODE SPECIFICATIONS.....	22
4.5	OPERATING THE WELDER (OPTIONAL REMOTE PANEL) .....	22
4.5.1	CC (CONSTANT CURRENT) MODE.....	23
4.5.2	CV (CONSTANT VOLTAGE) MODE - USING A VOLTAGE SENSING SUITCASE FEEDER OR SPOOL GUN .....	23
	TABLE 4C: WELDING ROD TYPE, POLARITY AND FLUX CODES .....	24
4.6	OPERATING THE BATTERY BOOSTER/CHARGER .....	24
4.6.1	CONNECTION - DISCONNECTION SEQUENCE AND OPERATION .....	25
4.7	OPERATING THE GENERATOR.....	26
4.8	OPERATING THE AIR COMPRESSOR .....	26
4.9	OPERATING THE (OPTIONAL) BATTERY CHARGER FOR STAND-ALONE SYSTEMS .....	27
4.9.1	CONNECTION - DISCONNECTION SEQUENCE AND OPERATION .....	27
4.10	EXTREME CONDITION OPERATION.....	28

## **SECTION 5: MAINTENANCE ..... 29**

5.1	GENERAL INFORMATION .....	29
5.2	ROUTINE MAINTENANCE SCHEDULE .....	29
5.3	MAINTENANCE SCHEDULE TABLE .....	30
5.4	REPLACEMENT PARTS.....	34
5.5	PARTS REPLACEMENT AND ADJUSTMENT PROCEDURES .....	34
5.5.1	ADJUSTING COMPRESSOR CUT-IN / CUT-OUT PRESSURE .....	35
5.5.2	ADJUSTING THE ENGINE SPEED.....	36
5.5.3	REPLACING AND RE-TENSIONING THE COMPRESSOR AND/OR GENERATOR DRIVE BELTS.....	36

<b>Continued on next page...</b>
----------------------------------

## **SECTION 5: MAINTENANCE (CONTINUED)**

- 5.5.3.1 ACCESSING THE DRIVE BELTS - REMOVING THE BELT GUARD SHIELD .....36
- 5.5.3.2 REPLACING THE BELT GUARD SHIELD.....36
- 5.5.3.3 RE-TENSIONING THE AIR COMPRESSOR DRIVE BELT .....36
- 5.5.3.4 COMPRESSOR BELT SIZING .....37
- 5.5.3.5 COMPRESSOR BELT LINK DISENGAGEMENT.....38
- 5.5.3.6 COMPRESSOR BELT ASSEMBLY .....38
- 5.5.3.7 TRACKING COMPRESSOR BELT ONTO PULLEY GROOVE .....39
- 5.5.3.8 RE-TENSIONING OR REPLACING THE GENERATOR SERPENTINE BELT .....41
- 5.5.3.9 RE-TENSIONING THE GENERATOR SERPENTINE BELT .....41
- 5.5.3.10 REPLACING THE GENERATOR SERPENTINE DRIVE BELT.....41
- 5.5.4 *SERVICING THE FUSE*.....42
- 5.6 STORAGE AND INTERMITTENT USE..... 43
  - 5.6.1 *INTERMITTENT USE*.....43
  - 5.6.2 *LONG TERM STORAGE*.....43

## **SECTION 6: TROUBLESHOOTING ..... 45**

- 6.1 GENERAL INFORMATION ..... 45
- 6.2 TROUBLESHOOTING GUIDE ..... 46
- 6.3 EXTREME CONDITION OPERATION ..... 53
  - 6.3.1 *COLD WEATHER OPERATION* ..... 53
    - 6.3.1.1 ENGINE OPERATION .....53
  - 6.3.2 *HIGH TEMPERATURE OPERATION*.....54
  - 6.3.3 *HIGH ALTITUDE OPERATION*.....54

## **SECTION 7: ILLUSTRATED PARTS LIST.....55**

- 7.1 PARTS ORDERING PROCEDURE..... 55
  - TABLE 7A: RECOMMENDED SPARE PARTS LIST..... 56
  - TABLE 7B: MAINTENANCE TRACKING LOG..... 57
- 7.2A ANA 150 SYSTEMS ASSEMBLIES (8 GALLON, STAND ALONE, WELD ONLY, 12V AND 12/24V BATTERY BOOST) ..... 58
- 7.2B ANA 150 SYSTEMS ASSEMBLIES (30 GALLON, STAND ALONE, WELD ONLY, 12V AND 12/24V BATTERY BOOST) ..... 60
- 7.2C ANA 150 SYSTEMS ASSEMBLIES (STAND ALONE, SKID MOUNT, 12V AND 12/24V BATTERY BOOST) ..... 62

***Continued on next page...***

## **SECTION 7: ILLUSTRATED PARTS LIST (CONTINUED)**

7.2D ANA 150 SYSTEMS ASSEMBLIES (8 GALLON, REMOTE PANEL, WELD ONLY, 12V AND 1 2/24V BATTERY BOOST) .....	64
7.2E ANA 150 SYSTEMS ASSEMBLIES (30 GALLON, REMOTE PANEL, WELD ONLY, 12V AND 12/24V BATTERY BOOST) .....	66
7.2F ANA 150 SYSTEMS ASSEMBLIES (REMOTE PANEL, SKID MOUNT, WELD ONLY, 12V AND 12/24V BATTERY BOOST) .....	68
7.3 COMPRESSOR AND PARTS .....	70
7.4A FRAME ASSEMBLY (ALL 8 GALLON MODELS) .....	72
7.4B FRAME ASSEMBLY (ALL 30 GALLON MODELS) .....	74
7.4C FRAME ASSEMBLY (ALL SKID-MOUNT MODELS) .....	76
7.5A CONTROL ASSEMBLY (SKID MOUNT, 8 GALLON, 30 GALLON MODELS) .....	78
7.5B CONTROL ASSEMBLY (8 GALLON, STAND ALONE MODELS) .....	80
7.5C CONTROL ASSEMBLY (30 GALLON, STAND ALONE MODELS) .....	82
7.5D CONTROL ASSEMBLY (REMOTE PANEL, SKID MOUNT MODELS) .....	84
7.5E CONTROL ASSEMBLY (ALL STAND ALONE, SKID MOUNT MODELS) .....	86
7.5F CONTROL ASSEMBLY (ALL 8 GALLON, REMOTE PANEL MODELS) .....	88
7.6A ENGINE AND DRIVE PARTS (ALL STAND ALONE MODELS) .....	90
7.6B ENGINE AND DRIVE PARTS (ALL REMOTE PANEL MODELS) .....	92
7.7 BELT GUARD ASSEMBLY .....	94
7.8A ELECTRICAL SYSTEM (ALL MODELS EXCEPT REMOTE PANEL MODELS) .....	96
7.8B ELECTRICAL SYSTEM (ALL REMOTE PANEL MODELS) .....	100
7.9A AIR STORAGE ASSEMBLY (ALL 8 GALLON, STAND ALONE AND REMOTE PANEL MODELS) .....	104
7.9B AIR STORAGE ASSEMBLY (ALL 30 GALLON, STAND ALONE MODELS) .....	106
7.9C AIR STORAGE ASSEMBLY (ALL 30 GALLON, REMOTE PANEL MODELS) .....	106
7.10A FUEL TANK ASSEMBLY (ALL 8 GALLON MODELS) .....	108
7.10B FUEL TANK ASSEMBLY (ALL 30 GALLON MODELS) .....	110
7.10C FUEL TANK ASSEMBLY (ALL FUEL PUMP/REMOTE MODELS) .....	112
7.11 DECAL LOCATIONS .....	114
7.12 WIRING DIAGRAM - AIR N ARC 150 .....	116
7.13 WIRING DIAGRAM - AIR N ARC 150 REMOTE PANEL .....	117
7.14 FLOW SCHEMATIC DIAGRAM .....	118
7.15A INSTALLATION AND DIMENSIONS - 8 GALLON TANK .....	122
7.15B INSTALLATION AND DIMENSIONS - 30 GALLON TANK .....	123
7.15C INSTALLATION AND DIMENSIONS - SKID MOUNT .....	124
7.16 HOSE INSTALLATION GUIDE .....	125

**BLANK PAGE**



# WARRANTY CLAIMS PROCEDURE

## CLAIMS PROCESS FOR WARRANTED VANAIR PARTS

This process must be used by owners of Vanair® equipment in situations where a warranted item needs repair or replacement under the terms of the purchase warranty. Do not return items to Vanair without prior authorization from the Vanair Warranty Administrator.

### PROCEDURE:

When a customer needs assistance in troubleshooting a system and/or returning parts, follow the steps below.

**1. Locate the machine's serial number:**

The machine package serial number plate is located inside the machine compartment on the floor next to the generator mounting location (see *Figure W-1*).

The engine and the compressor also have individual serial numbers respectively (see *Figure W-1*). For engine warranty issues, consult the Engine Operator's Manual for the engine's limited warranty details. For particular compressor unit issues, the compressor serial number may be needed. In any case, engine and/or compressor issues can be confirmed using the machine serial number as found in *Figure W-1*.

**2. Have a list of the symptoms/condition/malfunctions along with any applicable temperature and pressure readings, and also the number of operational hours available:**

Note that the above information will also need to be included on the Return Material

Authorization Form (per **Step #6**); this form is necessary for warranty processing if the warranty claim is deemed valid by the service case review.

- 3. Contact the Vanair® Service Department by phone (1-844-VAN-SERV) to speak with a Service Technician.**
- 4. Vanair Service will troubleshoot the problem based on the information provided by the customer, and attempt to return the unit to service as quickly as possible.**
- 5. If the unit cannot be returned to service, and Vanair determines this matter is a warranty issue, the Service Technician will assign an RMA (Return Material Authorization) number that will provide for the return of the item to Vanair for analysis and a final determination as to the item's warranty status.**

<b>NOTE</b>
The RMA number must be placed on the outside of the package being returned.

- 6. Warranty Claims are solicited via a Return Material Authorization (RMA) Form. This form can be obtained via download from the web site, or requested directly from the Vanair Service Department:**

Once a current form has been obtained, follow the instructions given on the form to fill in the information needed. This form is used for the purpose of soliciting a warranty case. All of the field information **except** for the bottom section block fields, which include

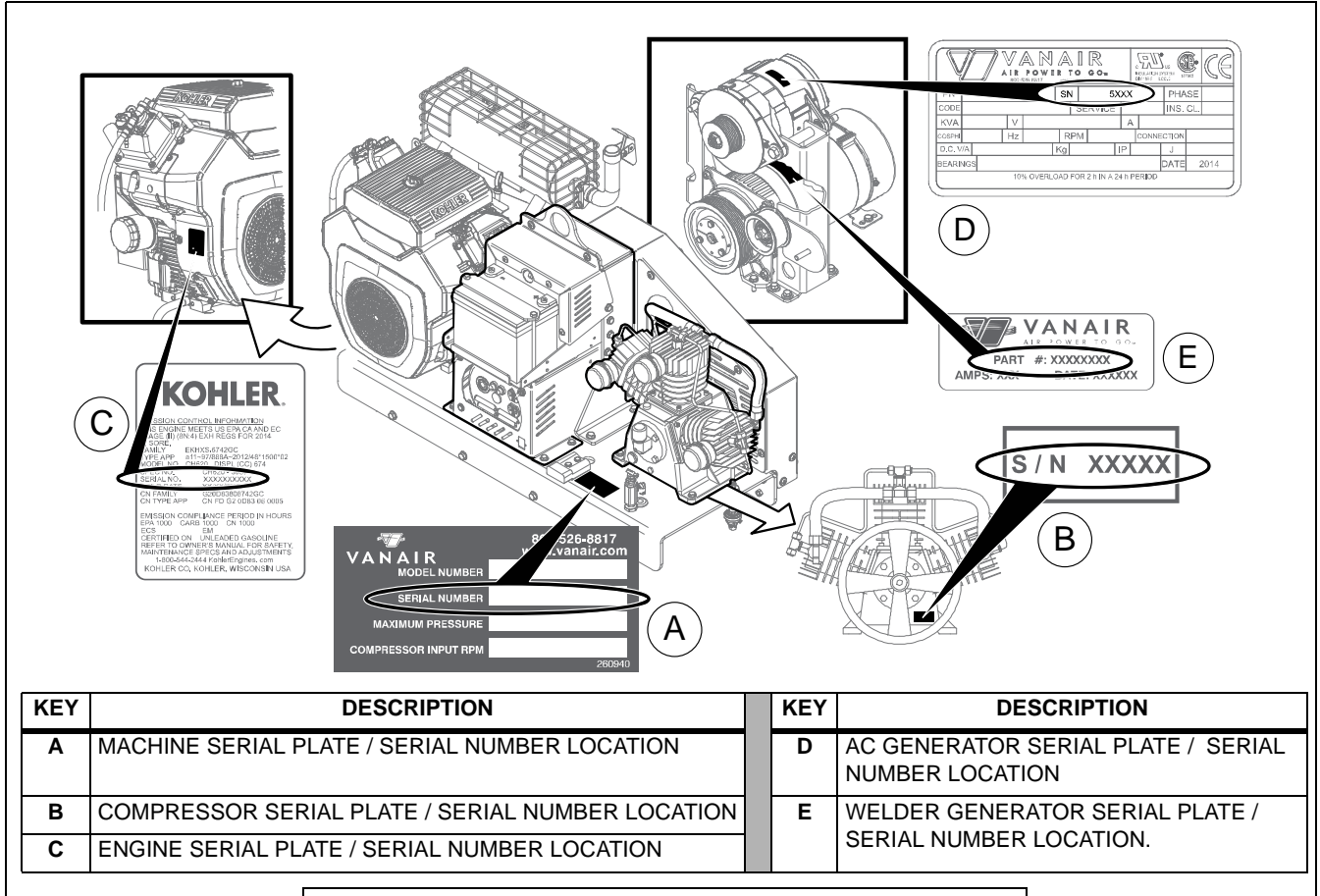

**Figure W-1: Machine Serial Number Location**

Disposition of Goods, Notifications and Additional Notes, will be required.

Customers have 30 days after the RMA number is issued to return the item. If the part is not returned within this period, the RMA is void and any claims will be denied.

**NOTE**

**All labor claims or invoices must be approved by the Vanair Warranty Administrator prior to starting repair work along with the cost of the repair. All paperwork associated with the returned item and warranty repair cost must reference the RMA number issued against the part, and be forwarded to Vanair within 30 days of the completion of work.**

Before sending a warranty part to a customer, Vanair® will need a P.O. or credit card number to cover the cost of the part and shipping. After the part is analyzed and deemed to be covered under warranty,

Vanair will issue credit to the customer. All parts eligible for warranty must have the RMA number on the invoice at the time of purchase.

No items can be returned "freight collect". Freight costs will be addressed at the time the claim is closed. The customer pays any additional costs for warranty parts delivered through expedited services (i.e., Next Day, Second Day).



**VAN AIR WILL NEVER ACCEPT ANY INVOICES FOR PARTS RETURNED: ANY PARTS RETURNED VIA INVOICE WILL BE RETURNED FREIGHT COLLECT: NO PARTS ARE TO BE RETURNED FREIGHT COLLECT!**

Vanair Mfg., Inc. strives to continuously improve its customer service. Please forward any questions, comments, or suggestions to Vanair Service (1-844-VAN-SERV) or e-mail us (warranty@vanair.com).

# SECTION 1: SAFETY

## 1.1 GENERAL INFORMATION

The products provided by Vanair® Manufacturing, Inc. are designed and manufactured for safe operation and maintenance. However, it is ultimately the responsibility of the users and maintainers for safe use of this equipment. Part of this responsibility is to read and be familiar with the contents of this manual before operation or performing maintenance actions.

 <b>IMPORTANT</b>

<p><b>It is mandatory that all operators read this manual before operating or servicing the Air N Arc 150 Series All-In-One Power System. Failure to do so could result in death, bodily injury or damage to equipment.</b></p>

## 1.2 DANGERS, WARNINGS, CAUTIONS, AND NOTES

 <b>DANGER</b>
<p><b>Identifies actions or conditions which will cause death, severe injury, equipment damage or destructive malfunctions.</b></p>

 <b>WARNING</b>
<p><b>Identifies actions or conditions which may cause death, severe injury, equipment damage or destructive malfunctions.</b></p>

 <b>CAUTION</b>
<p><b>Identifies actions or conditions which will or can cause injuries, equipment damage or malfunctions.</b></p>

<b>NOTE</b>
<p><b>Additional information (or existing information) which should be brought to the attention of operators/maintainers affecting safety, operation, maintenance, or warranty requirements.</b></p>

## 1.3 INTERNATIONAL SAFETY SYMBOL

The symbols shown and defined in **Section 1: Safety** are used throughout this manual to call attention to and identify possible hazards.



The international warning symbol shown above is used on all decals, labels and signs that concern information pertaining to bodily harm. When you see the international warning symbol, **pay extremely careful attention** and follow the given instructions or indications to avoid any possible hazard.

## 1.4 ARC WELDING HAZARDS

### 1.4.1 ELECTRICAL SHOCK CAN KILL



Touching live electrical parts can cause fatal shocks or severe burns. The electrode and work circuit are electrically live whenever the

output is on. The input power circuit and machine internal circuits are also live when power is on. In semi-automatic or automatic wire welding, the wire, wire reel, drive roll housing, and all metal parts touching the welding wire are electrically live. Incorrectly installed or improperly grounded equipment is a hazard.

Do not touch live electrical parts.

Wear dry, hole-free insulating gloves and body protection.

Insulate yourself from work and ground using dry insulating mats or covers big enough to prevent any physical contact with the work or ground.

Do not use AC output in damp areas, if movement is confined, or if there is a danger of falling.

Additional safety precautions are required when working in electrically hazardous conditions such as in damp locations or while wearing wet clothing; on metal structures such as floors, gratings, or scaffolds; when in cramped positions such as sitting, kneeling, or lying; or when there is a high risk of unavoidable or accidental contact with the work piece or ground.

Do not work alone!

Disconnect input power or stop engine before installing or servicing this equipment. Lockout/tag out input power according to OSHA29 CFR1910.147 (see **Section 1.9, Principal Safety Standards**).

Properly install and ground this equipment according to its Owner's Manual and national, state, and local codes.

Always verify the supply ground: check and ensure that input power cord ground wire is properly connected to ground terminal in disconnect box or that cord plug is connected to a properly grounded receptacle outlet.

When making input connections, attach proper grounding conductor first and double-check connections.

Frequently inspect input power cord for damage or bare wiring and replace cord

immediately if damaged—bare wiring can kill.

Turn off all equipment when not in use.

Do not use worn, damaged, undersized, or poorly spliced cables.

Do not drape cables over your body.

If earth grounding of the work piece is required, ground it directly with a separate cable.

Do not touch electrode if you are in contact with the work, ground, or another electrode from a different machine.

Use only well-maintained equipment. Repair or replace damaged parts at once. Maintain unit according to manual.

Do not touch electrode holders connected to two welding machines at the same time since double open-circuit voltage will be present.

Wear a safety harness if working above floor level.

Keep all panels and covers securely in place.

Clamp work cable with good metal-to-metal contact to work piece or work table as near to the weld as practical.

Insulate work clamp when not connected to workpiece to prevent contact with any metal object.

Do not connect more than one electrode or work cable to any single weld output terminal.

#### 1.4.2 **FUMES AND GASES CAN BE HAZARDOUS**

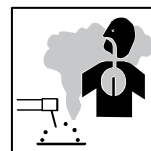

Welding produces fumes and gases. Breathing these fumes and gases can be hazardous to your health.

Keep your head out of the fumes. Do not breathe the fumes.

If inside, ventilate the area and/or use local forced ventilation at the arc to remove welding fumes and gases.

If ventilation is poor, wear an approved air-supplied respirator.

Read and understand the Material Safety Data Sheets (MSDSs) and the manufacturer's instructions for metals, consumables, coatings, cleaners, and degreasers.

Work in a confined space only if it is well ventilated, or while wearing an air-supplied respirator. Always have a trained watch person nearby.

Welding fumes and gases can displace air and lower the oxygen level causing injury or death. Be sure the breathing air is safe.

Do not weld in locations near degreasing, cleaning, or spraying operations.

The heat and rays of the arc can react with vapors to form highly toxic and irritating gases.

Do not weld on coated metals, such as galvanized, lead, or cadmium-plated steel, unless the coating is removed from the weld area, the area is well-ventilated, and while wearing an air-supplied respirator. The coatings and any metals containing these elements can give off toxic fumes if welded.

### 1.4.3 **BUILD UP OF GAS CAN INJURE OR KILL**



Shut off shielding gas supply when not in use.

Always ventilate confined spaces or use approved air-supplied respirator.

### 1.4.4 **ENCLOSED SPACES CAN CAUSE A BUILD-UP OF NOXIOUS FUMES AND OVERHEATING**

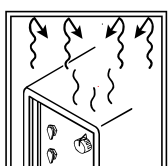

Do not use in enclosed spaces where deadly exhaust gases can build up and machine can overheat, causing fire.

### 1.4.5 **ARC RAYS CAN BURN EYES AND SKIN**

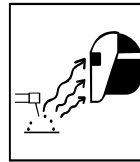

weld.

Wear an approved welding helmet fitted with a proper shade of filter lenses to protect your face and eyes from arc rays and sparks when welding or watching.

(See ANSI Z49.1 and Z87.1 listed in Safety Standards). Wear approved safety glasses with side shields under your helmet.

Use protective screens or barriers to protect others from flash, glare, and sparks; warn others not to watch the arc.

Wear protective clothing made from durable, flame-resistant material (leather, heavy cotton, or wool) and foot protection.

### 1.4.6 **WELDING CAN CAUSE FIRE AND EXPLOSION**

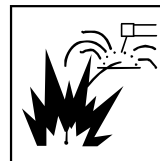

Welding on closed containers, such as tanks, drums, or pipes, can cause them to blow up. Sparks can fly off from the welding arc.

The flying sparks, hot workpiece, and hot equipment can cause fires and burns. Accidental contact of electrode to metal objects can cause sparks, explosion, overheating, or fire. Check and ensure the area is safe before doing any welding.

Remove all flammables within 35 feet (10.7 m) of the welding arc. If this is not possible, tightly cover them with approved covers.

Do not weld where flying sparks can strike flammable material.

Protect yourself and others from flying sparks and hot metal.

Be alert that welding sparks and hot materials from welding can easily go through small cracks and openings to adjacent areas.

Watch for fire, and keep a fire extinguisher nearby.

Be aware that welding on a ceiling, floor, bulkhead, or partition can cause fire on the hidden side.

Do not weld on closed containers such as tanks, drums, or pipes, unless they are properly prepared according to AWSF4.1 (See **Section 1.9, Principal Safety Standards**).

Connect ground cable as close to the welding area as practical to prevent welding current from traveling long, possibly unknown paths and causing electric shock, sparks, and fire hazards.

Do not use welder to thaw frozen pipes.

Remove stick electrode from holder or cut off welding wire at contact tip when not in use.

Wear oil-free protective garments such as leather gloves, heavy shirt, cuffless trousers, boots, and a cap.

Remove any combustibles, such as a butane lighter or matches, from your person before doing any welding.

Follow requirements in OSHA1910.252 (a) (2) (iv) and NFPA 51B for hot work and have a fire watcher and extinguisher nearby.

### 1.4.7 **FLYING METAL CAN INJURE EYES**

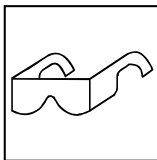

Sparks and flying metal can be caused by welding, chipping, wire brushing, and grinding. As welds cool, they can throw off slag.

Wear approved safety glasses with side shields even under your welding helmet.

### 1.4.8 **HOT PARTS CAN CAUSE SEVERE BURNS**



Do not touch hot parts bare handed.

Allow cooling period before working on equipment.

To handle hot parts, use proper tools and/or wear heavy, insulated welding gloves and clothing to prevent burns.

### 1.4.9 **NOISE CAN DAMAGE HEARING**

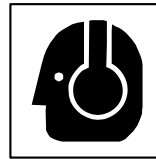

Noise from some processes or equipment can damage hearing.

Wear approved ear protection if noise level is high.

### 1.4.10 **MAGNETIC FIELDS CAN AFFECT PACEMAKERS**

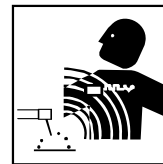

Pacemaker wearers keep away.

Wearers should consult their doctor before going near arc welding, gouging, or spot welding operations.

Shielding gas cylinders contain gas under high pressure. If damaged, a cylinder can explode. Since gas cylinders are normally part of the welding process, be sure to treat them carefully.

### 1.4.11 **CYLINDERS CAN EXPLODE IF DAMAGED**

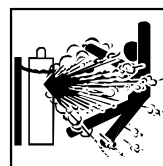

Protect compressed gas cylinders from excessive heat, mechanical shocks, physical damage, slag, open flames, sparks, and arcs.

Install cylinders in an upright position by securing to a stationary support or cylinder rack to prevent falling or tipping.

Keep cylinders away from any welding or other electrical circuits.

Never drape a welding torch over a gas cylinder.

Never allow a welding electrode to touch any cylinder.

Never weld on a pressurized cylinder—explosion will result.

Use only correct shielding gas cylinders, regulators, hoses, and fittings designed for the specific application; maintain them and associated parts in good condition.

Turn face away from valve outlet when opening cylinder valve.

Keep protective cap in place over valve except when cylinder is in use or connected for use.

Use the right equipment, correct procedures, and sufficient number of persons to lift and move cylinders.

Read and follow instructions on compressed gas cylinders, associated equipment, and Compressed Gas Association (CGA) publication P-1 listed in Safety Standards.

## 1.5 ENGINE HAZARDS

### 1.5.1 BATTERY EXPLOSION CAN BLIND

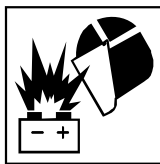

Always wear a face shield, rubber gloves, and protective clothing when working on a battery.

Stop engine before disconnecting or connecting battery cables or servicing battery.

Do not allow tools to cause sparks when working on a battery.

Do not use weld mode to charge batteries or jump start vehicles.

Observe correct polarity (+ and -) on batteries.

Disconnect negative (-) cable first and connect it last.

### 1.5.2 FUEL CAN CAUSE FIRE OR EXPLOSION



Stop engine and let it cool off before checking or adding fuel.

Always keep nozzle in contact with tank when fueling.

Do not add fuel while smoking or if unit is near any sparks or open flames.

Do not overfill tank—allow room for fuel to expand.

Do not spill fuel. If fuel is spilled, clean up before starting engine.

Dispose of rags in a fireproof container.

### 1.5.3 MOVING PARTS CAN CAUSE INJURY



Keep away from fans, belts, and rotors. Keep all doors, panels, covers, and guards closed and securely in place.

Stop engine before installing or connecting unit.

Have only qualified people remove doors, panels, covers, or guards for maintenance and troubleshooting as necessary.

Disconnect negative (-) battery cable from battery to prevent accidental starting during servicing.

Keep hands, hair, loose clothing, and tools away from moving parts.

Reinstall doors, panels, covers, or guards when servicing is finished and before starting engine.

Before working on generator, remove spark plugs or injectors to keep engine from kicking back or starting.

Block flywheel so that it will not turn while working on generator components.

**1.5.4 ⚠️ HOT PARTS CAN CAUSE SEVERE BURNS**



Do not touch hot parts bare handed.

Allow cooling period before working on equipment.

**1.5.5 ⚠️ ENGINE EXHAUST GASES CAN KILL**

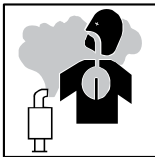

If used in a closed area, vent engine exhaust outside and away from any building air intakes.

**1.5.6 ⚠️ ENCLOSED SPACES CAN CAUSE A BUILD-UP OF NOXIOUS FUMES AND OVERHEATING**

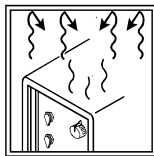

Do not use in enclosed spaces where deadly exhaust gases can build up and machine can overheat, causing fire.

**1.5.7 ⚠️ BATTERY ACID CAN BURN SKIN AND EYES**

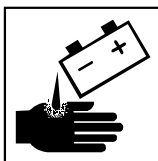

Do not tip battery.

Replace damaged battery.

Flush eyes and skin immediately with water.

**1.5.8 ⚠️ ENGINE HEAT CAN CAUSE FIRE**

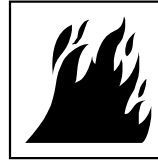

Do not locate unit on, over, or near combustible surfaces or flammables.

Keep exhaust and exhaust pipes way from flammables.

**1.5.9 ⚠️ EXHAUST SPARKS CAN CAUSE FIRE**



Use approved engine exhaust spark arrester in required areas — see applicable codes.

**1.6 COMPRESSED AIR HAZARDS**

**1.6.1 ⚠️ BREATHING COMPRESSED AIR CAN CAUSE SERIOUS INJURY OR DEATH**

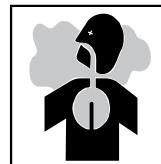

Do not use compressed air for breathing.

Use only for cutting, gouging, and tools.

**1.6.2 ⚠️ ENCLOSED SPACES CAN CAUSE A BUILD-UP OF NOXIOUS FUMES AND OVERHEATING**

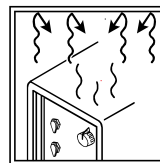

Do not use in enclosed spaces where deadly exhaust gases can build up and machine can overheat, causing fire.



**1.6.3 ⚠ COMPRESSED AIR CAN CAUSE INJURY**

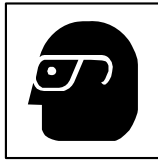

Wear approved safety goggles.

Do not direct air stream toward self or others.

**1.6.4 ⚠ TRAPPED AIR PRESSURE AND WHIPPING HOSES CAN CAUSE INJURY**

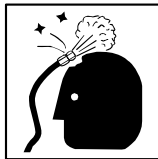

Release air pressure from tools and system before servicing, adding or changing attachments, or opening compressor oil drain or oil fill cap.

**1.6.5 ⚠ HOT METAL FROM AIR ARC CUTTING AND GOUGING CAN CAUSE FIRE OR EXPLOSION**



Do not cut or gouge near flammables.

Watch for fire; keep extinguisher nearby.

**1.6.6 ⚠ HOT PARTS CAN CAUSE SEVERE BURNS**



Do not touch hot parts bare handed.

Allow cooling period before working on equipment.

**1.6.7 ⚠ READ INSTRUCTIONS**



Read Owner's Manual before using or servicing unit.

Stop engine and release air pressure before servicing.

Use only genuine Air N Arc replacement parts.

**It is mandatory that all operators read this manual before operating or servicing the Air N Arc 150 Series All-In-One Power System. Failure to do so could result in death, bodily injury, or damage to equipment.**

**1.7 ADDITIONAL SYMBOLS FOR INSTALLATION, OPERATION AND MAINTENANCE**

**1.7.1 ⚠ FALLING UNIT CAN CAUSE INJURY**



Use lifting bail to lift unit and properly installed accessories only.

Lift and support unit only with proper equipment and correct procedures.

If using lift forks to move unit, be sure forks are long enough to extend beyond opposite side of unit.

**1.7.2 ⚠ OVERHEATING CAN DAMAGE MOTORS**

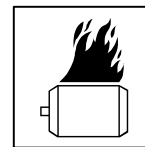

Turn off or unplug equipment before starting or stopping engine.

Do not let low voltage and frequency caused by low engine speed damage electric motors.

**1.7.3 ⚠ FLYING SPARKS CAN CAUSE INJURY**

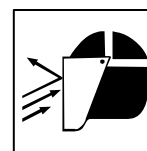

Wear a face shield to protect eyes and face.

Shape tungsten electrode only on grinder with proper guards in a safe location wearing proper face, hand, and body protection.

Sparks can cause fires—keep flammables away.

### 1.7.4 **▲ OVERUSE CAN CAUSE OVERHEATING**

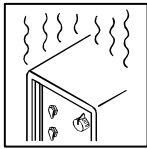

Allow cooling period; follow rated duty cycle.

Reduce current or reduce duty cycle before starting to weld again.

Do not block or filter airflow to unit.

### 1.7.5 **▲ ENCLOSED SPACES CAN CAUSE A BUILD-UP OF NOXIOUS FUMES AND OVERHEATING**

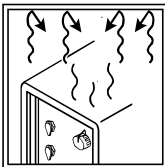

Do not use in enclosed spaces where deadly exhaust gases can build up and machine can overheat, causing fire.

### 1.7.6 **▲ TILTING OF TRAILER CAN CAUSE INJURY**



Use tongue jack or blocks to support weight.

Properly install unit onto trailer according to instructions supplied with trailer.

### 1.7.7 **▲ READ INSTRUCTIONS**



Use only genuine Air N Arc replacement parts.

Perform engine and air compressor (if applicable) maintenance and service according to this manual

and the engine/air compressor (if applicable) manuals.

### 1.7.8 **▲ H. F. RADIATION CAN CAUSE INTERFERENCE**

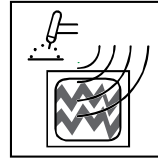

High-frequency (H.F.) can interfere with radio navigation, safety services, computers, and communications equipment.

Allow only qualified persons familiar with electronic equipment to perform this installation.

The user is responsible for having a qualified electrician promptly correct any interference problem resulting from the installation.

If notified by the FCC about interference, stop using the equipment at once.

Have the installation regularly checked and maintained.

Keep high-frequency source doors and panels tightly shut, keep spark gaps at correct setting, and use grounding and shielding to minimize the possibility of interference.

### 1.7.9 **▲ ARC WELDING CAN CAUSE INTERFERENCE**

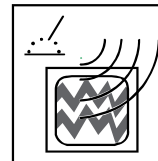

Electromagnetic energy can interfere with sensitive electronic equipment such as microprocessors, computers, and computer-driven equipment such as

robots.

Be sure all equipment in the welding area is electromagnetically compatible.

To reduce possible interference, keep weld cables as short as possible, close together, and down low, such as on the floor.

Locate welding operation 100 meters from any sensitive electronic equipment.

Be sure this welding machine is installed and grounded according to this manual.

If interference still occurs, take extra measures such as moving the welding

machine, using shielded cables, using line filters, or shielding the work area.

## 1.8 CALIFORNIA PROPOSITION 65 WARNINGS

Welding or cutting equipment produces fumes or gases which contain chemicals known to the State of California to cause birth defects and, in some cases, cancer. (California Health & Safety Code Section 25249.5 et seq.)

Battery posts, terminals and related accessories contain lead and lead compounds, chemicals known to the State of California to cause cancer and birth defects or other reproductive harm. Wash hands after handling.

For Gasoline Engines: Engine exhaust contains chemicals known to the State of California to cause cancer, birth defects, or other reproductive harm.

For Diesel Engines: Diesel engine exhaust and some of its constituents are known to the State of California to cause cancer, birth defects, and other reproductive harm.

## 1.9 PRINCIPAL SAFETY STANDARDS

Safety in Welding, Cutting, and Allied Processes, ANSI Standard Z49.1, from Global Engineering Documents (phone: 1-877-413-5184, website:www.global.ihs.com).

Recommended Safe Practices for the Preparation for Welding and Cutting of Containers and Piping, American Welding Society Standard AWSF4.1, from Global Engineering Documents (phone: 1-877-413-5184, web site: www.global.ihs.com).

National Electrical Code, NFPA Standard 70, from National Fire Protection Association, P.O. Box 9101, 1 Battery March Park, Quincy, MA 02269-9101 (phone: 617-770-3000, web site: www.nfpa.org and www.sparky.org).

Safe Handling of Compressed Gases in Cylinders, CGA Pamphlet P-1, from Compressed Gas Association, 1735 Jefferson Davis Highway, Suite 1004, Arlington, VA 22202-4102 (phone: 703-412-0900, web site: www.cganet.com).

Code for Safety in Welding and Cutting, CSA Standard W117.2, from Canadian Standards Association, Standards Sales, 178 Rexdale Boulevard, Rexdale, Ontario, Canada M9W 1R3 (phone: 800-463-6727 or in Toronto 416-747-4044, web site: www.csainternational.org).

Practice For Occupational And Educational Eye And Face Protection, ANSI Standard Z87.1, from American National Standards Institute, 11 West 42nd Street, New York, NY 10036-8002 (phone: 212-642-4900, web site: www.ansi.org).

Standard for Fire Prevention During Welding, Cutting, and Other Hot Work, NFPA Standard 51B, from National Fire Protection

Association, P.O. Box 9101, 1 Battery March Park, Quincy, MA 02269-9101 (phone: 617-770-3000, web site: www.nfpa.org).

OSHA, Occupational Safety and Health Standards for General Industry, Title 29, Code of Federal Regulations (CFR), Part 1910, Subpart Q, and Part 1926, Subpart J, from U.S. Government Printing Office, Superintendent of Documents, P.O. Box 371954, Pittsburgh, PA 15250 (there are 10 Regional Offices; phone for Region 5, Chicago, is 312-353-2220, web site: www.osha.gov).

## 1.10 EMF INFORMATION

Considerations about welding and the effects of low frequency electric and magnetic fields welding current, as it flows through welding cables, will cause electromagnetic fields.

There has been and still is some concern about such fields. However, after examining more than 500 studies spanning seventeen years of research, a special blue ribbon committee of the National Research Council concluded that: "The body of evidence, in the

committee's judgment, has not demonstrated that exposure to power-frequency electric and magnetic fields is a human-health hazard." However, studies are still going forth and evidence continues to be examined. Until the final conclusions of the research are reached, you may wish to minimize your exposure to electromagnetic fields when welding or cutting.

To reduce magnetic fields in the workplace, use the following procedures:

1. Keep cables close together by twisting or taping them.
2. Arrange cables to one side and away from the operator.
3. Do not coil or drape cables around your body.
4. Keep welding power source and cables as far away from operator as possible.
5. Connect work clamp to workpiece as close to the weld as possible.

#### About Pacemakers:

Pacemaker wearers consult your doctor before welding or going near welding operations. If cleared by your doctor, then following the above procedures is recommended.

## 1.11 SAFETY DECALS

Safety decals are placed onto, or located near, system components that can present a hazard to operators or service personnel. All pertinent decals listed in **Section 7.11, Decal Locations** are located near a component, which is subject to respect in terms of safety precautions. Always heed the information noted on the safety decals.

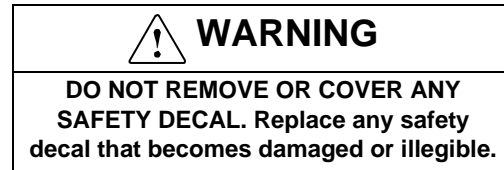

## 1.12 DISPOSING OF MACHINE FLUIDS

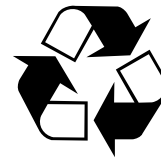

Always dispose of machine fluids under the guidance of all applicable local, regional and/or federal law.

Vanair encourages recycling when allowed. For additional information, consult the container for information.

# SECTION 2: SPECIFICATIONS

**TABLE 2A: WELDER, GENERATOR, AND ENGINE SPECIFICATIONS**

SYSTEM INFORMATION	SPECIFICATION
Rated Welder Output	150A High Frequency DC/CC; 100% Duty Cycle @ 150 Amps
Welding Leads	25 or 50 Ft Optional (Refer to Section A.5 for Optional Parts Listing)
AC Generator	4,200 Watts Continuous Duty
AC Generator 120V Power Rating	60 Hz 1 PH, 20 Amp Circuit
AC Generator 240V Power Rating	60 Hz 1 PH, 20 Amp
Battery Charger Capacity	12V Charge, 12V Boost, 24V Boost
Engine	19 HP <sup>I</sup>
Engine Oil Capacity	Two (2) Quarts 10W30 (Refer to Engine Operator's Manual for Extreme Conditions)
Fuel Consumption	1.5 GPH at Full Engine Speed/Load 9.6 Hour Runtime w/ 12 Gallon Tank
Fuel Tank Capacity	4.5 Gallons or 11.5 Gallons
Fuel Type	86 Octane or Higher Unleaded Gasoline <sup>II</sup>
Operating Temperature Limits	0°F to 110°F <sup>III</sup>
<sup>I</sup> For in-depth specifications and requirements regarding the Kohler® 19 HP engine, refer to the Engine Operator's Manual.	
<sup>II</sup> Ethanol blended fuels, such as E85, are prohibited for use with the Kohler engine. <b>DO NOT</b> use ethanol-based fuels.	
<sup>III</sup> With cold weather kit, temperature range expands to -40° below.	

**TABLE 2B: SPECIFICATIONS — AIR COMPRESSOR**

COMPRESSOR INFORMATION	SPECIFICATION
Compressor Type	Reciprocating, single-stage
Air Compressor Capacity	20 CFM @ 100 PSI
Inlet Control	Zero (0) No Load / 100% Load
Air Filter	Pleated Paper, Dry Type, and Pre-Filter
Oil Capacity/Type	<b>New:</b> 3 Quarts / <b>Service:</b> 24 ounces Vanguard™ Premium Reciprocating Synthetic Oil
Air Tank Capacity	Eight (8) Gallons, Thirty (30) Gallons or Remote Tank
Tank Pressure Rating	200 PSI
Safety Relief Valve Setting	150 PSI
Electrical System	12 VDC
Instrument Gauges	Pressure and Hour Meter
Adjustable Air Pressure Control Settings	Cut-in Pressure: 90 PSI / Cut-out Pressure: 125 PSI
Air Service Outlets	Two (2) on Control Panel - Remote, One (1) on Machine - Standalone

**TABLE 2C: SPECIFICATIONS — UNIT WEIGHT AND DIMENSIONS**

<b>Dimensions (Overall Package)</b>	<b>Length (in)</b>	<b>Width (in)</b>	<b>Height (in)</b>	<b>Weight (lbs) (wet)</b>
<b>Skid-Mount</b>	50.34	18.20	24.24	425
<b>Tank-Mount, 30 Gallon</b>	50.74	19.00	40.75	565
<b>Tank-Mount, 8 Gallon</b>	50.50	21.00	30.25	510

# SECTION 3: INSTALLATION

## 3.1 MACHINE PACKAGE RECEIPT/INSPECTION

Upon receipt of the machine package, inspect the exterior of the shipping crate for signs of shipping/transit damage. Any damage should be reported immediately to the shipping company. Open the lid and inspect the component parts and supports to ensure that there has been no internal movements of assemblies or components which may have caused damage. Contact Vanair Manufacturing, Inc. to report missing items, incorrect part number, or other discrepancies:

### Vanair Manufacturing, Inc.

10896 West 300 North  
 Michigan City, IN 46360  
 Phone: (219) 879-5100  
 (800) 526-8817  
 Service: (844)VANSERV  
 [844-826-7378]  
 Service Fax: (219) 879-5335  
 Parts Fax: (219) 879-5340  
 Sales Fax: (219) 879-5800

## 3.2 MACHINE PACKAGE PREP

### DANGER

Grounding must consist of a minimum 10 gauge wire between the instrument panel, the machine, and the truck chassis.

### DANGER

DO NOT install in enclosed spaces.

### WARNING

**ELECTRICAL HAZARD!** Be sure the battery is disconnected before starting the installation.

### NOTE

Install electrical components (circuit breakers, pressure switches, toggle switches, etc.) in locations where exposure to water or moisture will be most minimized.

### NOTE

In order to prevent accidental damage to vehicle components (fuel tanks, lines, brake lines, wiring harnesses), note their location before drilling any holes.

### WARNING

Installation must adhere to the safety precautions listed in the Safety Section of this manual for cooling and noxious fume ventilation.

If mounting footprint is tighter than the recommended minimum requirements, consult the Vanair Service Department for application installation recommendations.

### NOTE

For guidance on machine start-up procedure and control panel functions, consult *Section 4, Operation*.

Refer to **Sections 7.15A, 7.15B and 7.15C** for **Installation and Dimension** diagrams, and the following instructions:

1. Remove packing and inspect the machine and control panel for shipping damage.
2. Check fluid levels, if needed. Refer to the Engine Operation Manual for engine oil.

### 3.3 SERVICE BODY PREP

Consult **Sections 7.15A, 7.15B and 7.15C** for **Installation and Dimension** (dimensional) requirements, and the following instructions:

1. Drill four (4) 1/2" mounting holes in the service body floor in a square pattern at the desired mounting location. Ensure that all proper machine clearances will be maintained.

### 3.4 STABILIZING PRECAUTIONS FOR MACHINE MOUNTING

Machine should be mounted to vehicle using a minimum of four (4) isolators. Isolators absorb vibration and allow for a complete sealing of the machine to the mounting surface. Isolators are available from Vanair®: order bolt down isolator, part number PR271935 (quantity of 4). **Do Not** permanently bolt machine down until after all instructions in **Section 3** have been addressed.

### 3.5 MACHINE PACKAGE MOUNTING

When determining package position on vehicle, be aware of the minimum space requirements needed for cooling and circulation, and also package access for performing maintenance (see **Sections 7.15A, 7.15B and 7.15C** for **Installation and Dimension** diagrams). To prepare the machine for mounting, follow the succeeding procedure:

1. Unbolt the unit from the skid:  
remove the mounting nuts, lock

washers, washers and mounting bolts securing the machine to the shipping crate.

2. Using a proper hoist, lift and place the unit in a preliminary position on the service body of the vehicle so that access is easily attained and there is enough space surrounding the mounting area for cooling purposes.
3. Leaving the unit in the preliminary position, connect the ground cable to the unit battery and check all fluid levels (**NOTE:** vehicle should be on a level surface in order to get accurate fluid level checks).
4. Move the unit into its final location for mounting, while positioning the control trunk line and all other connections.

Bolt the machine down with four (4) 3/8" bolts inserted up from the bottom through the four mounting bolt holes of the base frame. See **Sections 7.15A, 7.15B and 7.15C** for **Installation and Dimension** diagrams.

#### NOTE

**It is recommended that the machine be mounted on a vibration isolating material such as 1/4" neoprene rubber pads.**

**Isolating Dampeners (Part Number PR93969) are available by calling Vanair.**

Start the unit and fully test all functions. Warm the unit to full operating temperature. After the unit has cooled, check all fluid levels and add as needed.

### 3.6 CONNECTING THE FUEL SYSTEM (IF REQUIRED)

To connect to the fuel pump, refer to **Figure 3-1** and follow these steps:

1. Mount the electric fuel pump at the desired location on the service body, keeping it as close to the truck fuel tank as possible. Mount the electric fuel pump a maximum



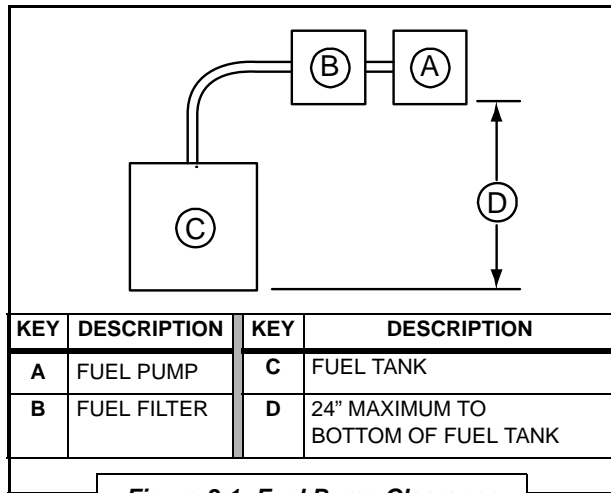

**Figure 3-1: Fuel Pump Clearance**

- distance of 24 inches from the bottom of the tank (**Figure 3-1**).
- Install the pick-up and fuel line.
    - Ensure that the lines do not make contact with sharp edges, moving parts or exhaust heat. Consult **Section 7.17, Hose Installation Guide** for assistance in running hose lines.
    - Units must have a 70 micron fuel filter in line before the pump.

Due to the length involved for the fuel line assembled from the engine to the vehicle-accessed fuel tank, the fuel line may accumulate air. There is a bleed nut located on the engine for the purpose of siphoning off this air.

	<p><b>IMPORTANT</b></p> <p>The Vanair-supplied fuel pump includes an internal check valve; do not add an external check valve.</p>
--	--

### 3.7 INSTALLING THE REMOTE CONTROL PANEL

For remote instrument panel mounting, install the remote control panel at the desired location on the service body and route the control trunk-line to the location where the unit will mount. Ensure that all

sharp edges on the trunk-line contacts are shielded or grommet-protected, and that there are no excessively sharp ends in the trunk-line. Ensure the trunk-line does not come in contact with exhaust parts.

### 3.8 INSTALLING (OPTIONAL) REMOTE AIR TANK

<p><b>NOTE</b></p> <p>When determining the location of the air tank, keep in mind that the drain valve will need to be accessed on a frequent (daily) basis.</p>
--

<p><b>NOTE</b></p> <p>Ensure that the lines do not make contact with sharp edges, moving parts or exhaust heat. Consult <b>Section 7.17, Hose Installation Guide</b>, for assistance in running hose lines.</p>
---

The air tank and subsequent piping must have a minimum rating of **200 psi**; if tank is larger than six inches (6") OD, it must be ASME rated. To determine the location of a remote-mounted air tank, consider the following:

- Air system piping relation to the ANA 150 Series machine.
- Hindrance to any access or operation of other standard or mounted vehicle system(s), including any underdeck or accessible wiring, piping, etc.
- Service output location.

To prepare and install the remote air tank, follow these guidelines.

For compressor discharge piping, use a 1/2" minimum, S-TW Series hose (that meets SAE 100R14A), extruded PTFE tube with stainless steel single wire braid. The working pressure and temperature ratings should be: 200 psi air @ 400°F.

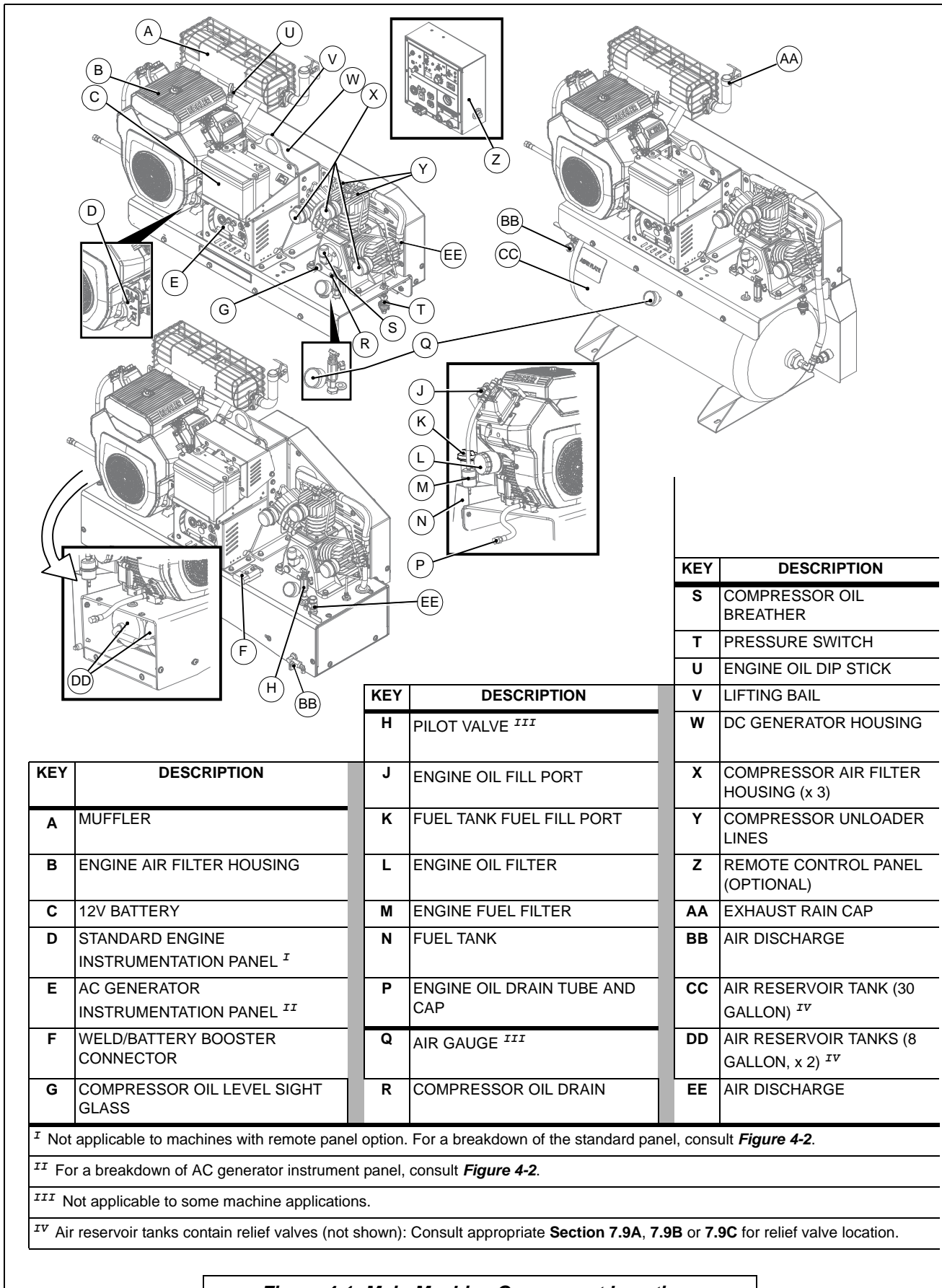

<sup>I</sup> Not applicable to machines with remote panel option. For a breakdown of the standard panel, consult **Figure 4-2**.

<sup>II</sup> For a breakdown of AC generator instrument panel, consult **Figure 4-2**.

<sup>III</sup> Not applicable to some machine applications.

<sup>IV</sup> Air reservoir tanks contain relief valves (not shown): Consult appropriate **Section 7.9A, 7.9B or 7.9C** for relief valve location.

**Figure 4-1: Main Machine Component Locations**

# SECTION 4: OPERATION

## 4.1 GENERAL INFORMATION

Consult *Figure 4-1*. The Air N Arc 150 Series machine has a comprehensive array of controls and indicators for each function of the machine system. Understanding the correct operation of the Air N Arc 150 Series system will help you to understand and recognize when the system is operating optimally. The information in the Operation Section will help the operator to recognize and interpret the readings, which will call for service or indicate the beginning of a malfunction.

### NOTE



Before starting the Air N Arc 150 Series machine, read this section thoroughly and familiarize yourself with the controls and indicators - their purpose, location and use.



### DANGER

Grounding must consist of a minimum 10 gauge wire between the instrument panel, the machine, and the truck chassis.



### WARNING

Follow all applicable safety recommendations as outlined in *Section 1: Safety* of this manual.



### WARNING

Before performing maintenance or repair operations on the machine, disconnect battery and relieve air pressure.

### NOTE

If start-up and shut-down procedures are not followed, damage to the system and its components may occur.

### NOTE

If the generator switches are set to ON prior to starting, and/or the pressure in the air tank is less than 10 psi, the machine will start at full speed.

## 4.2 ENGINE START-UP AND SHUTDOWN PROCEDURE

Consult *Figure 4-2: Instrumentation*, for operating procedures detailed in this section.

### NOTE

For machines that utilize the remote panel option, a visual breakdown of panel function by control feature can be found by consulting *Figure 4-3*.

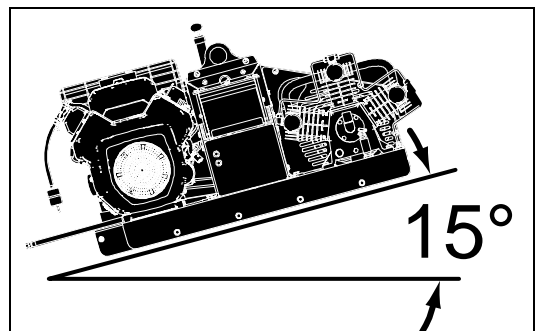

All machine package maximum operation angles of tilt are fifteen degrees (15°).

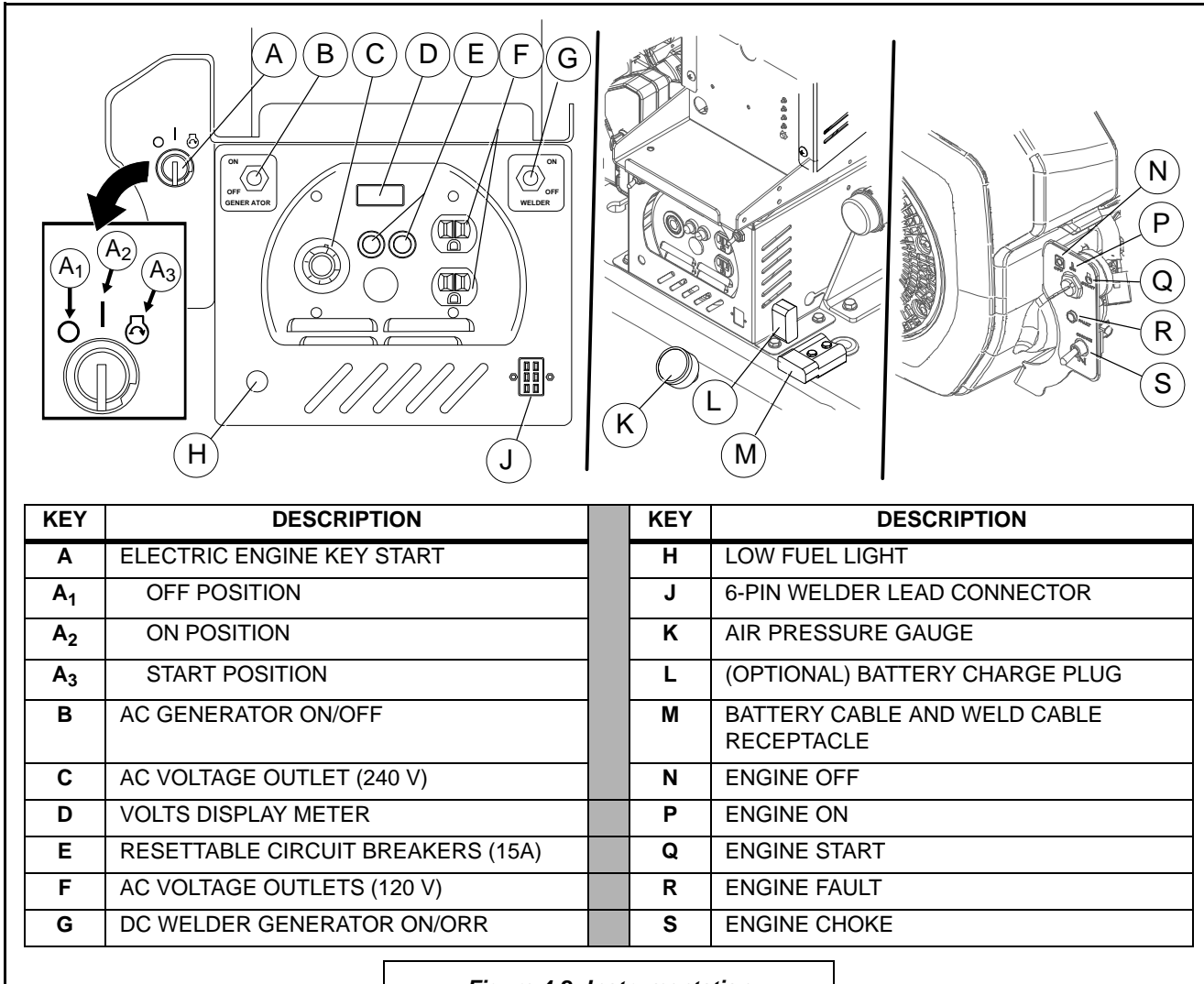

Figure 4-2: Instrumentation

### 4.2.1 ENGINE START-UP

1. Check to make sure all switches (for Welder and Generator) are in the **OFF** position prior to starting (Consult **Figure 4-2** and **Figure 4-3**.)

**NOTE**

**Air compressor will start automatically with machine start-up.**

2. Turn the engine control switch from the **OFF** position to the **ON** position.
3. Continue turning control switch to the **START** position [A<sub>3</sub>] until the engine starts (when the switch is let go, it will revert back to **ON** position).

4. Let engine run at idle for a 3-5 minutes to allow for warm up sequence.

### 4.2.2 ENGINE SHUTDOWN

Consult **Figure 4-2**. To shut the engine off at any time, turn the engine control switch to the **OFF** position [A<sub>1</sub>]. However, this method is best reserved for emergency shutdown situations only.

**CAUTION**

**Compressors and engines generate heat and create hot surfaces. Use caution when operating and servicing equipment. Some surfaces and components may be hot.**

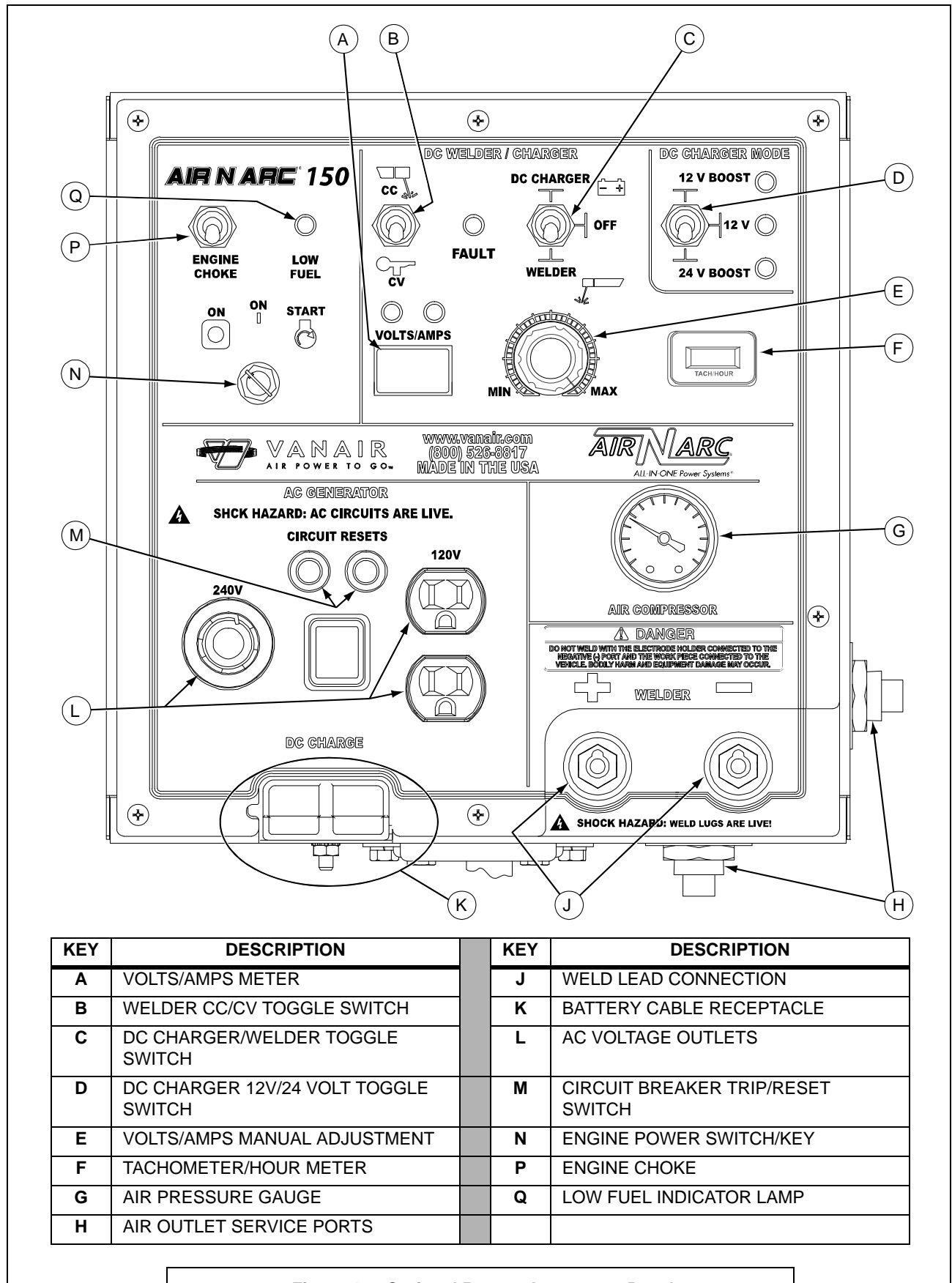

KEY	DESCRIPTION	KEY	DESCRIPTION
A	VOLTS/AMPS METER	J	WELD LEAD CONNECTION
B	WELDER CC/CV TOGGLE SWITCH	K	BATTERY CABLE RECEPTACLE
C	DC CHARGER/WELDER TOGGLE SWITCH	L	AC VOLTAGE OUTLETS
D	DC CHARGER 12V/24 VOLT TOGGLE SWITCH	M	CIRCUIT BREAKER TRIP/RESET SWITCH
E	VOLTS/AMPS MANUAL ADJUSTMENT	N	ENGINE POWER SWITCH/KEY
F	TACHOMETER/HOUR METER	P	ENGINE CHOKE
G	AIR PRESSURE GAUGE	Q	LOW FUEL INDICATOR LAMP
H	AIR OUTLET SERVICE PORTS		

**Figure 4-3: Optional Remote Instrument Panel**

Vanair Mfg., Inc. recommends that the following procedure is used for routine shutdowns in order to keep the system in optimal condition, and minimize undue stress that may occur during the next start up session if some of the machine conditions were left in working mode(s) or had auxiliary power draws left intact (such as a tool receptacle left plugged into the generator, etc.).

To prepare the machine for shutdown:

1. Shut off any tools or other items that are drawing power from the generator, or compressed air from the air tank.
2. Close all service valves.
3. Unplug any power cords that are plugged into the generator panel.
4. Turn the **Generator** and **Welder** switches on the control panel (**Figure 4-2, [B & G]**) to their **OFF** positions.
5. Allow machine to run at idle for a 3-5 minutes to allow for a cool down sequence.
6. Turn the **Engine Control Switch** to the **OFF** position [**A<sub>1</sub>**]. If no air leaks are present, the engine should start

at idle speed the next time it is started.

**NOTE**

Refer to **Engine Owner's Manual** for additional information pertaining to the starting of the engine.

### 4.3 ENGINE THROTTLE CONTROL FUNCTIONS

The engine speed is controlled by three factors:

1. The level of air pressure in the tank and the position of the pilot valve adjustment switch (refer to **Figure 4-4**).
2. The position of the welder switch on the unit control panel, and the use of the welder.
3. The position of the generator switch on the control panel.

**Consult Table 4A: Engine Throttle Control Function Conditions** to understand how the engine speed relates to the demand(s) of the machine system's output functions.

TABLE 4A: ENGINE THROTTLE CONTROL FUNCTION CONDITIONS <sup>I</sup>			
Pressure Setting	Generator Switch	Welder Switch	Engine Speed Condition Result
Tank Pressure Below (<) 100 PSI or Set Pressure <sup>II</sup>	OFF	OFF	Engine runs at full throttle.
Tank Pressure Above (≥) 100 PSI or Set Pressure <sup>II</sup>	OFF	OFF	Engine runs at idle speed, ready for application.
	OFF	ON	Welder can be activated by striking an arc with engine running at full throttle and button is depressed on electrode holder.
	ON	OFF	Engine runs at full throttle speed (3600 RPM); generator is ready for use.
	ON	ON	Full speed and all items available for use.

<sup>I</sup> Any combination of the 150 Power System output functions (compressor, generator, welder) used simultaneously at capacity will have an adverse affect on engine running at full throttle.

<sup>II</sup> Factory set pressure: 95 PSI = ON / 125 PSI = OFF

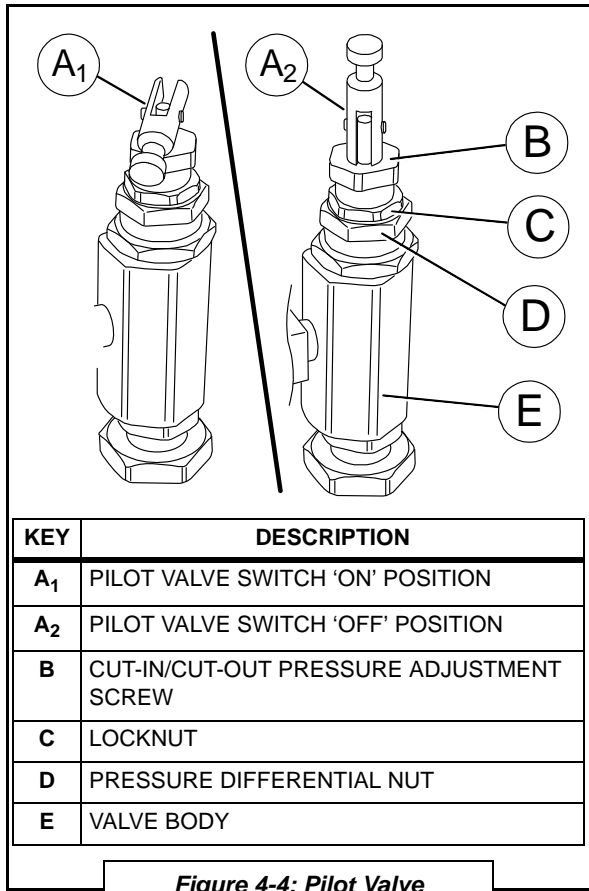

1. The Power Button: When power is desired at the welding lead, the Power Button must be pressed and held for the duration of the weld.
2. The Boost Button: When the Boost Button is pressed and held, full amperage is sent to the welding lead regardless of the Power Dial setting. When the button is released, amperage will return to the preset power level.
3. The Power Dial: The infinitely variable Power Dial adjusts the welder amperage from 40 - 190 amps. Turning the Power Dial counterclockwise decreases the amperage. The Power Dial may be adjusted while welding.

**OPERATING PROCEDURE**

1. With the engine shut off, insert the large plug on the welding lead into the welding lead receptacle.
2. Insert the small 6-pin plug on the welding lead into the 6-pin receptacle referencing the pin spacing to properly orientate the plug.

**NOTE**

If a longer welding lead is desired, optional 50 ft. lead segments may be purchased from Vanair for a maximum lead length of 100 ft.

## 4.4 OPERATING THE WELDER



**WARNING**

Before attempting any welding procedure, the operator must be aware of general safety practices, and particularly those pertaining to welding, as found in *Section 1.4* of this manual.

The amperage and power controls are built into the welding lead. The Air N Arc welding lead is equipped with remote welding controls for maximum operator efficiency.

There are three controls on the hand-grip of the welding lead:

3. Select the appropriate electrode for the material and process being performed. See **Table 4B** for selecting an electrode.
4. Place the ground clamp on the work piece and insert the appropriate welding rod into the electrode clamp.
5. Start the engine (See **Section 4.2, Engine Startup and Shutdown Procedure**).
6. Place the Welder switch on the control panel to the On position.

**TABLE 4B: ELECTRODE SPECIFICATIONS**

METAL THICKNESS	ELECTRODE SIZE	WELDING AMPERES
1/16-1/8	3/32	50-90
1/8-1/4	1/8	90-140
1/4-3/8	5/32	120-180
3/8-1/2	3/16	150-230

7. Adjust the Power Dial on the welding lead to a mid-range setting (approximately 40-50% for an 1/8" rod).
8. Push and hold the Power Button on the welding lead. Power will be supplied to the welding lead and the engine will increase speed. The Power Button must be held down for the duration of the weld.
9. If there is difficulty in starting the arc due to rust or paint, push the Boost Button momentarily for 100% power while starting the arc. Release the Boost Button when a stable arc is achieved and the amperage level will return to the Power Dial setting.
10. At any time during welding, the weld amperage may be adjusted to the desired level with the Power Dial.

**NOTE**

The Power Button must be held down in addition to the Boost Button for the welder to function, during boost mode.

11. When completed with a weld, release the Power Button. Power to the welding lead will be turned off and the engine will slow to idle speed after a 30 second delay.

**NOTE**

If the customer wishes to reverse the welding polarity, a polarity reversing adapter is available from your local dealer.

## 4.5 OPERATING THE WELDER (OPTIONAL REMOTE PANEL)



**WARNING**

Before attempting any welding procedure, the operator must be aware of general safety practices, and particularly those pertaining to welding, as found in *Section 1.4* of this manual.

Consult *Figure 4-5*. The **variable power dial** adjusts the welder amperage (0 to 150 amps), or voltage (15 to 40 volts) for the desired weld heat. Turning the power dial clockwise increases the amperage or voltage, and turning the power dial counterclockwise decreases the amperage or voltage. The power dial may be adjusted while welding.

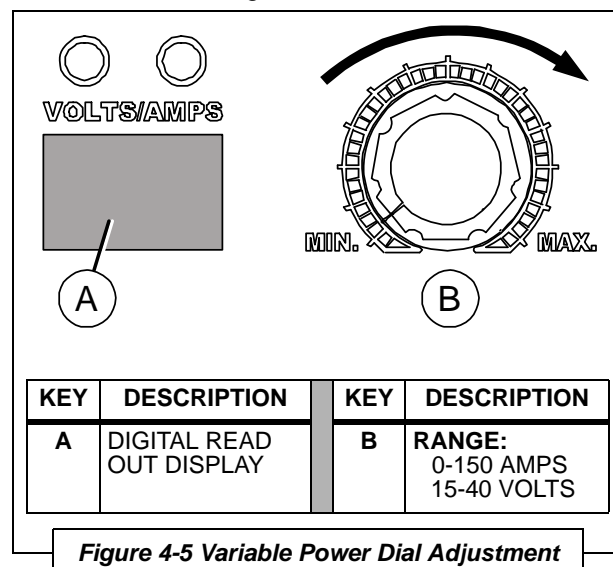

**Figure 4-5 Variable Power Dial Adjustment**



### 4.5.1 CC (CONSTANT CURRENT) MODE

CC (Constant Current) Mode is commonly referred to as - Stick Welding, Arc Welding, or Shielded Metal Arc Welding (SMAW).

1. With the engine shut off, insert the twist lock connections of the work clamp and the electrode holder cables into the welder connection ports on the control panel. For Direct Current Electrode Positive (DCEP), connect the electrode holder to the positive (+) port, and the work clamp to the negative (-) port.



#### **DANGER**

**DO NOT weld with the electrode holder connected to the negative (-) port and the work piece connected to the vehicle. Bodily harm and equipment damage may occur.**

2. Select the appropriate electrode for the material and process being performed. See **Table 4B: ELECTRODE SPECIFICATIONS** for selecting an electrode.
3. Place the ground clamp on the work piece and insert the appropriate welding rod into the electrode clamp.
4. Start the engine (**See Section 4.2, Engine Start-up and Shutdown Procedure**).
5. On the control panel, place the CC/CV switch in CC mode. Place the DC Charger/Welder switch in welder mode.
6. Adjust the power dial to the appropriate amperage setting for the material and the electrode being used. (See **Table 4B: ELECTRODE SPECIFICATIONS** for electrode amperage ratings). At anytime during welding, the power dial may be adjusted to the desired amperage level.

#### **NOTE**

**The amps/volts display will read the set value for five (5) seconds when the dial is adjusted, and the actual output value five (5) seconds after the dial has been adjusted.**

7. When you strike the electrode against the material being welded, the engine will go to high idle and deliver the selected amperage through the electrode. Welding can now begin.
8. After a weld has been completed, and there is no contact between the electrode and the metal for 30 seconds, the engine will return to idle.

#### **NOTE**

**If a longer welding lead is desired, optional 25 and 50 ft. lead segments may be purchased from Vanair® Manufacturing, Inc. for a maximum lead length of 100 ft.**

### 4.5.2 CV (CONSTANT VOLTAGE) MODE - USING A VOLTAGE SENSING SUITCASE FEEDER OR SPOOL GUN

CV (Constant Voltage) Mode – commonly referred to as - Wire Welding, MIG welding, or Gas Metal Arc Welding (GMAW)

#### **NOTE**

**When using a spool gun, an adapter with contactor must be used. Please consult the spool gun manufacturer for appropriate adapter.**

1. With the engine shut off, insert the twist lock connection of the ground clamp into the negative (-) welder connection port on the control panel. Insert the power lead segment from the suitcase feeder into the positive (+) welder connection port on the control panel.

2. Place the ground clamp from the suitcase feeder and the ground clamp from the Air N Arc 150 on the work piece.
3. Start the engine (See Section 4.2, Engine Start-up and Shutdown Procedure).
4. On the control panel, place the DC Charger/Welder switch in welder mode. Place the CC/CV switch in CV mode.
5. Adjust the power dial on the Air N Arc 150 to the appropriate voltage setting for the material being welded. Adjust the power dial on the suitcase feeder for the material being welded. At anytime during welding, the power dial may be adjusted to the desired voltage level.

What the numbers mean that are used to identify a stick welding electrode:

Using E6010 for an example...

The “E” indicates Electrode because some welding rods are not electrodes. The “60” in 6010 indicates the tensile strength in psi. 60,000 lbs.

The last two (2) digits indicate position and polarity along with what type flux. See **Table 4C: WELDING ROD TYPE, POLARITY AND FLUX CODES.**

## 4.6 OPERATING THE BATTERY BOOSTER/CHARGER

The Vanair state-of-the-art battery charging module and the optional battery charging cables add further versatility to the 150 Series Power System. The battery charging system operates off the welding generator, and not the main AC power generator.

 <b>WARNING</b>
<b>DO NOT charge or boost while in Weld Mode. Personal injury or damage may occur.</b>

The module has been factory-adjusted for 12 VDC charging, and a maximum current output of 150 amps.

The module output has been set at 14 VDC for the 12V charge option, 16 VDC for 12V boost, and 30 VDC for the 24V option. This output has been pre-set by the factory and

**TABLE 4C: WELDING ROD TYPE, POLARITY AND FLUX CODES**

DIGIT	TYPE OF COATING	WELDING CURRENT
10	High cellulose sodium	DC+
11	High cellulose potassium	AC or DC+ or DC-
12	High titania sodium	AC or DC-
13	High titania potassium	AC or DC+
14	Iron powder titania	AC or DC- or DC+
15	Low hydrogen sodium	DC+
16	Low hydrogen potassium	AC or DC+
27	Iron powder iron oxide	AC or DC+ or DC-
18	Iron powder low hydrogen	AC or DC+
20	High iron oxide	AC or DC+ or DC-
22	High iron oxide	AC or DC-
24	Iron powder titania	AC or DC- or DC+
28	Low hydrogen potassium iron powder	AC or DC+

can only be adjusted by authorized factory personnel.

During charging, if the machine begins to cycle between high and low idle, then the battery is fully charged.

#### 4.6.1 CONNECTION - DISCONNECTION SEQUENCE AND OPERATION

 <b>WARNING</b>	
	<p>Always wear a face shield when connecting or disconnecting battery charging cables, and always follow the connection and disconnection sequence. Electrical sparks can cause a battery to explode, resulting in serious injury.</p>

 <b>CAUTION</b>	
<p>Exposed high pressure air lines on the unit become hot during operation—keep everyone clear.</p>	

 <b>IMPORTANT</b>	
<p>System will not give output without being connected to a battery.</p>	

 <b>IMPORTANT</b>	
<p>Never attach boost cables to the panel before attaching to the battery. Always attach cables to the battery first.</p>	

 <b>IMPORTANT</b>	
<p>Never leave the machine unattended while charging a battery. Always carefully monitor the charging system while it is in use; the high amperage level that the unit produces can damage the battery being charged, or the other components, if the unit is left connected for an extended period of time.</p>	

 <b>IMPORTANT</b>	
<p>Any combination of the 150 Power System output functions (compressor, generator, welder, hydraulic pump) used <i>simultaneously</i> will have an adverse affect of engine running at full throttle.</p>	

 <b>WARNING</b>	
<p><b>NEVER</b> disconnect boosting connections or cables while charging / boosting. This will cause a voltage spike on the machine. Failure to follow this warning can result in injury, and/or damage or failure of any or all electronic components, thus voiding the warranty of the machine.</p>	

 <b>IMPORTANT</b>	
<p>To prevent damaging voltage spikes, the battery cables must be disconnected from the battery to be charged in any vehicle equipped with a computer, or any equipment with sensitive electronic components. Failure to follow this warning can result in damage or failure of any or all electronic components, thus voiding the warranty of the machine.</p>	

1. With the engine off, insure that the welder, DC charger switch, and any other engine control switch is in the **OFF** position.
2. Attach the clamps of the battery charge cable to the battery to be charged. RED to the positive terminal, BLACK to the negative terminal (*Figure 4-5*).
3. Plug the battery charge cables into the battery cable connection.
4. Start the engine and wait for all indicator lights to turn off. Place the DC Welder/Charger selector toggle switch in the **DC Charger** position, and then the DC Charger Mode switch to the correct position. The engine should come up to operating speed; the battery is being charged.
5. When machine begins to cycle between high and low idle then the battery is fully charged.
6. To disconnect the charging system, place the DC Welder/Charger

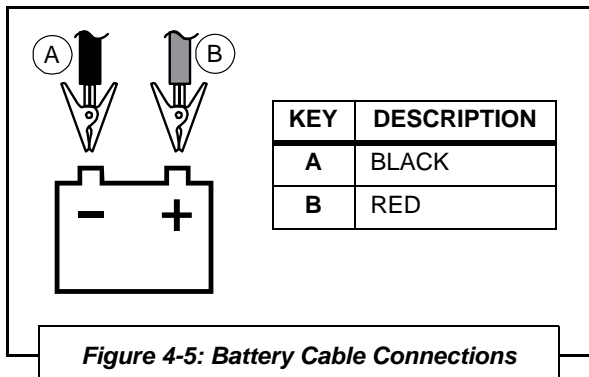

Figure 4-5: Battery Cable Connections

selector toggle switch to the **OFF** position.

7. Allow engine to idle down, then shut down the engine.
8. Now it is safe to disconnect the clamps from the battery being charged, and the battery cable connection on the front of the machine.

### 4.7 OPERATING THE GENERATOR

**! IMPORTANT**

Only plug power cords into the generator receptacles **AFTER** the engine is running at full speed.

**! IMPORTANT**

The Power System is designed to support a multi-function project. However, if the generator is operating at a high percentage of its rated capacity, and the welder and air compressor are also being used, the resulting drop in engine speed may produce a low voltage condition that will damage the generator and power tools being used.

**NOTE**

Be careful not to overload the rated capacity of the generator - 4,900 watts (20.4 amps @ 240V or 40.8 amps @ 120V for each outlet) continuous.

To operate the generator:

1. Start the engine.
2. Turn the Generator switch on the control panel to the **ON** position.

For general information on the power requirements of common power tools, motors and extension cords, check the desired power tool, motor or extension cord manufacturer's specifications.

If the thermal overload circuit breakers on the generator are tripped due to an overload condition, press the white reset buttons on the generator panel to reset the breakers (*Figure 4-2*).

**! WARNING**

If one of the generator circuit breakers is tripped, the cause of the overload must be determined before the circuit breaker is reset and work is resumed.

**! WARNING**

Do not rely on the thermal overload circuit breakers on the generator to protect personnel, power tools, or the generator. The thermal overload circuit breakers on the generator require time to overheat when the generator is operating in an overload condition — they do not provide instant protection against short circuiting or overload conditions. Always use GFCI protected extension cords and power strips when using the generator.

### 4.8 OPERATING THE AIR COMPRESSOR

The air compressor on the Air N Arc 150 Series machine is a continuous-run compressor. This means that the compressor continues to turn at all times, even when it is not building pressure in the air storage tank. The compressor is controlled by a pilot valve that provides an air pressure signal to the compressor head unloader valves.

When the air tank pressure builds to 125 psi, a spring loaded valve in the pilot valve

opens, providing an air pressure signal to the head unloader valves of the compressor. This causes the air in the compressor to vent to the atmosphere.

When the air tank pressure falls below 95 psi, the pilot valve will close, stopping the air signal to the unload valves, allowing the compressor to start pumping air to the tank.

### NOTE

**The leading cause of component failure of the air control system is moisture. Air tanks must be drained daily as a minimum to eliminate condensation.**

A lever on the top of the pilot valve will allow the operator to manually stop the compression of air by the compressor during initial engine start-up or if operation does not require the use of compressed air (**Figure 4-4**). Since the head unloader valves require air pressure to operate, there must be a minimum of 10 psi in the air tank to allow the valves to operate properly.

When purchasing air tools or planning a project, the rated capacity of the compressor (20 CFM @ 100 psi) will need to be taken into consideration. Check the desired power tool manufacturer's specifications to ensure that the tool capacity is within range of the compressor's operating scope.

## 4.9 OPERATING THE (OPTIONAL) BATTERY CHARGER FOR STAND-ALONE SYSTEMS

Your Air-N-Arc 150 Series machine also supports an optional Battery Charger for boosting/charging batteries. This option is offered in 12 VDC or 24 VDC configurations.

The battery charge options have been factory set at 15.3 VDC for the 12V option or 27.3V for the 24V option. Both have a maximum output of 150 Amps.

These settings may be adjusted, but only by a certified technician. If you have the need

for these settings to be changed, please call Vanair Service Support at 844-VAN-SERV (844-826-7378).

### 4.9.1 CONNECTION - DISCONNECTION SEQUENCE AND OPERATION

#### **WARNING**

**NEVER** disconnect boosting connections or cables while charging / boosting. This will cause a voltage spike on the machine. Failure to follow this warning can result in injury, and/or damage or failure of any or all electronic components, thus voiding the warranty of the machine.

#### **WARNING**

**ALWAYS** wear a face-shield when connecting or disconnecting battery charging cables and always follow the connection and disconnection sequence. Electrical sparks can cause a battery to explode, resulting in serious injury.

#### **IMPORTANT**

To prevent damaging voltage spikes, the battery cables must be disconnected from the battery to be charged in any vehicle equipped with a computer, or any equipment with sensitive electronic components. Failure to follow this warning can result in damage or failure of any or all electronic components, thus voiding the warranty of the machine.

#### **IMPORTANT**

The welder switch on the control panel controls the battery charging system.

1. Disconnect the battery from the equipment system so that it is completely isolated.

2. Place the welder, generator, and engine control switches on the control panel in the OFF position and remove the welder lead if it is installed.
3. Remove the 6-pin plug from the storage receptacle on the side of the control panel. Plug it into the 6-pin receptacle and plug the battery charging cables into the welder lead and booster cable receptacle.
4. Connect the battery charging cables to the battery that is to be charged.
5. Start the engine and place the welder switch on the control panel in the ON position. You are now charging the battery.
6. To disconnect the charging system, place the welder switch in the OFF position. Follow proper engine shut down procedures and shut down the engine. The cables can now be disconnected from the battery.

minimize the possibility of malfunctions that are prone to occur under certain ambient conditions. Refer to **Section 6.3, Extreme Condition Operation**, for additional information on variable ambient operating conditions, and adjustment adaptations that can be made accordingly.

### **IMPORTANT**

**ALWAYS carefully monitor the charging system while it is in use. The high amperage level that the unit produces can damage the battery being charged or other components if the unit is left connected for an extended period of time.**

### **WARNING**

**To avoid damage to the sensitive electronic controlled equipment from voltage spikes, the battery cables of the battery to be charged must be disconnected. Vanair Manufacturing is not responsible for any damage that might occur if this step is not followed.**

## 4.10 EXTREME CONDITION OPERATION

When operating in extreme cold or hot conditions, or at a high altitude, extra attention should be given to any indication that could lead to a serious problem. Preventative safeguards exist that can

# SECTION 5: MAINTENANCE

## 5.1 GENERAL INFORMATION

A strict maintenance program is the key to long life for the Air N Arc 150 Series package. Below is a program that, when adhered to, should keep the package in top operating condition. Refer to **Section 5.5, Parts Replacement and Adjustment Procedures** in this section of the manual for detailed descriptions of specific compressor system components.



### WARNING

**DO NOT** remove caps, plugs and/or other components when compressor is running or pressurized. Stop compressor and de-pressurize system prior to maintenance of system.

Wear personal protective equipment such as gloves, work boots, and eye and hearing protection as required for the task at hand.



### WARNING

Follow all applicable safety recommendations as outlined in *Section 1: Safety* of this manual.

### NOTE

Operating the machine package in a severe environment may require more frequent service intervals.

## 5.2 ROUTINE MAINTENANCE SCHEDULE

Vanair® considers the maintenance schedule given in **Section 5.3, Maintenance Schedule Table**, to be part of the warranty agreement with the customer. This maintenance regimen must be followed in order to protect the warranty of the machine package.

Vanair especially requires that a consistent service regimen be established for engine oil changes, and engine and compressor air filter servicing. The following schedule is designed so that many of the other maintenance tasks are completed when the engine and compressor air filters are serviced, and the engine oil is changed.

Please take a moment to acquaint yourself with the service schedule presented in **Section 5.3, Maintenance Schedule Table**.

For assistance in obtaining routine maintenance or replacement parts, consult **Section 7.1, Parts Ordering Procedure**, and **Table 7A: Recommended Spare Parts List**.

### NOTE

Follow the prescribed periodic maintenance (PM) schedule as recommended. Perform the required PM schedule at recommended intervals. Failure to follow this prescribed periodic maintenance at the recommended intervals will impair the package safety, performance characteristics, shorten the package's life, and will negatively affect the warranty coverage of the package.

5.3 MAINTENANCE SCHEDULE TABLE

	INTERVALS		NOTE		
	BREAK-IN PERIOD	MAINTENANCE SCHEDULE Hourly or Calendar Period - whichever comes first			
<p><b>WARNING</b></p> <p>Before performing maintenance: Shut down machine, relieve all system pressure and lock out all power, as per the Safety Section of this manual.</p> <p>Always clearly tag the start-up instrumentation.</p>	First 20 Hours of Operation	After 8 Hours or Daily	<p>If working in dusty or dirty conditions, reduce the recommended time intervals between servicing by half for engine and compressor oil change, and engine and compressor filter servicing.</p>		
	After 40 Hours or Weekly	Every 100 Hours or One Year		Every 200 Hours	After 600 Hours
<b>TASK</b>			<b>ACTION TO TAKE</b>		
1	Check tension of compressor poly-link drive belt	•		•	Tighten belts if necessary. Consult <b>Section 5.5.3.3</b> .
2	Change engine oil.	•		•	Consult the oil change procedure in the Engine Owner's Manual to change the engine oil.
3	Wash engine air pre-cleaner	•		•	Remove and wash engine air filter pre-cleaner: Consult the Engine Owner's Manual for procedure
4	Check engine oil level	•		•	Consult engine oil level check procedure in the Engine Owner's Manual to check the engine oil level.
5	Check and maintain compressor oil level at proper amount shown in the sight glass	•		•	Compressor must operate at oil levels within the parameters of the sight glass. Do not overfill or operate at low levels.
6	Check air tank for water accumulation	•		•	Drain any water from all air tanks entirely on a daily basis.
7	Inspect unit for oil leaks or damage	•		•	Visually note any leaks or evidence of leaks around the compressor unit and hose connections. Tighten any loose connection point where needed. Repair or replace any damaged part.
8	Inspect cooler fins (both engine and compressor) for contamination	•		•	Clean or clear as necessary.
				<b>Continued on next page</b>	



5.3 MAINTENANCE SCHEDULE TABLE

WARNING  Before performing maintenance: Shut down machine, relieve all system pressure and lock out all power, as per the Safety Section of this manual. Always clearly tag the start-up instrumentation.	INTERVALS						NOTE  If working in dusty or dirty conditions, reduce the recommended time intervals between servicing by half for engine and compressor oil change, and engine and compressor filter servicing.	
	BREAK-IN PERIOD	MAINTENANCE SCHEDULE Hourly or Calendar Period - whichever comes first						
		After 8 Hours or Daily	After 40 Hours or Weekly	Every 100 Hours or One Year	Every 200 Hours	After 600 Hours		After 1000 Hours
TASK	ACTION TO TAKE							
9 Inspect ventilation areas and surroundings		●	●	●	●	●	Ensure ventilation areas and surroundings are not blocked or clogged with debris. Clean or clear as necessary.	
10 Clean and inspect engine air filter		●	●	●	●	●	Consult the air filter procedure in the Engine Owner's Manual to change the engine air filter.	
11 Clean and inspect compressor air filters		●	●	●	●	●	Visually inspect compressor air filters. Refer to <b>Section 7.3</b> for air housing/air filter assembly.	
12 Check/clean all external parts of compressor and driver		●	●	●	●	●	A daily visual inspection will help to prevent dirt and debris build-up, which can affect machine operation. When cleaning external parts, always wait for machine surfaces to cool down before wiping off.	
13 Change compressor oil	●		●	●	●	●	Change compressor oil. Oil capacity (new): 3 quarts; capacity (service): 2 quarts. Use only Vanguard™ Premium Synthetic Oil. Refer to <b>Figure 4-1</b> for compressor oil fill port and sight glass locations.	
14 Check tension of air compressor drive belt and tighten if necessary			●	●	●	●	Consult <b>Section 5.5.3</b> for procedure on how to check and re-tension the drive belts.	
15 Replace the compressor air filters (x 3)				●	●	●	Replace the three (3) compressor air filters. Refer to <b>Section 7.3</b> for air housing/air filter assembly.	
16 Inspect air compressor drive belt and serpentine welder drive belt for wear, damage or excessive cracking				●	●	●	Ensure that the drive belts are in satisfactory operating condition, and are tensioned adequately. Should a belt need to be replaced, consult <b>Section 5.5.3</b> for belt maintenance procedures.	

Continued on next page

5.3 MAINTENANCE SCHEDULE TABLE

		INTERVALS							NOTE
		BREAK-IN PERIOD	MAINTENANCE SCHEDULE Hourly or Calendar Period - whichever comes first						
WARNING	Before performing maintenance: Shut down machine, relieve all system pressure and lock out all power, as per the Safety Section of this manual.  Always clearly tag the start-up instrumentation.	First 20 Hours of Operation	After 8 Hours or Daily	After 40 Hours or Weekly	Every 100 Hours or One Year	Every 200 Hours	After 600 Hours	After 1000 Hours	If working in dusty or dirty conditions, reduce the recommended time intervals between servicing by half for engine and compressor oil change, and engine and compressor filter servicing.
		TASK							
17	Check battery cables and connections					●	●	●	Clean and tighten as necessary. Replace any worn cables.
18	Inspect unit mounting bolts					●	●	●	Tighten any loose mounting bolts as necessary.
19	Blow out the DC welding generator and AC generator					●	●	●	Use compressed air to clear out generators ( <b>NOTE:</b> carry out every 100 hours if operating in dirty environmental conditions.)
20	Replace engine fuel filter					●	●	●	Consult the procedure in the Engine Owner's Manual on how to change the engine filter.
21	Check compressor cut-in and cut-out pressures						●	●	Ensure that the cut-in and cut-out pressure settings are correct. Adjust if necessary. Refer to <b>Section 5.5.1.1</b> .
22	Replace engine spark plug (Check at 200 hours)							●	Consult the procedure in the Engine Owner's Manual on how to change the spark plugs.
23	Replace engine air filter						●	●	Consult the procedure in the Engine Owner's Manual on how to change the air filter.
24	Check the engine speed							●	Ensure that the engine speed is running at correct interval. Adjust if necessary, per <b>Section 5.5.2</b> .
25	Inspect the welding leads and battery charging cables							●	If so equipped, ensure that welding leads are satisfactory for operation (no cracks or advanced wear). Repair or replace as necessary.
<b>Continued on next page</b>									

5.3 MAINTENANCE SCHEDULE TABLE

WARNING	INTERVALS							ACTION TO TAKE		
	BREAK-IN PERIOD	MAINTENANCE SCHEDULE								
		Hourly or Calendar Period - whichever comes first	After 8 Hours or Daily	After 40 Hours or Weekly	Every 100 Hours or One Year	Every 200 Hours	After 600 Hours		After 1000 Hours	
<p><b>WARNING</b></p> <p>Before performing maintenance: Shut down machine, relieve all system pressure and lock out all power, as per the Safety Section of this manual.</p> <p>Always clearly tag the start-up instrumentation.</p>	First 20 Hours of Operation								<p><b>NOTE</b></p> <p>If working in dusty or dirty conditions, reduce the recommended time intervals between servicing by half for engine and compressor oil change, and engine and compressor filter servicing.</p>	
<b>TASK</b>										
26	Inspect welding electrode clamp and ground clamp							●	●	Ensure that welding electrode and ground clamps are in satisfactory condition for operation (no cracks or advanced wear). Repair or replace as necessary.
27	Replace the air compressor and generator drive belts							●	●	Consult <b>Section 5.5.3</b> on how to replace and re-tension the drive belts.
28	Inspect the generators and the automatic belt tensioner							●	●	Ensure that the automatic belt tensioner is free of rough, noisy or worn bearings.
29	Inspect compressor head valves. Clean the carbon from valves and head if necessary								●	Consult Factory Service Department for assistance.
30	Check and tighten all bolts, nuts, etc., if necessary	●							●	Check all bolt and nut fastenings to assure tightness, and/or correct torque values where applicable. Check more frequently under heavy use conditions.
31	Check compressor unloader valve(s) operation								●	Consult Factory Service Department for assistance.

**NOTE: Consult your local dealer for additional, non-routine maintenance procedures.**

## 5.4 REPLACEMENT PARTS

Replacement parts should be purchased through your local representative or where the Air N Arc 150 Series machine was purchased. If, for any reason, parts are not available in this manner, they can be purchased through the Vanair® Parts Department directly.

### Vanair Manufacturing, Inc.

10896 West 300 North  
Michigan City, IN 46360

Phone: (219) 879-5100  
(800) 526-8817

Service: (844) VANSERV  
[844-826-7378]

Service Fax: (219) 879-5335

Parts Fax: (219) 879-5340

Sales Fax: (219) 879-5800

www.vanair.com

#### NOTE

For assistance when ordering new replacement parts, consult *Section 7.1, Parts Ordering Procedure*, and *Table 7A: Recommended Spare Parts List*.

#### NOTE

Use only Genuine Air N Arc parts. Inspect and replace damaged components before operation. Substituting non-Air N Arc components **WILL VOID THE WARRANTY!**

#### NOTE

If additional spare parts are being stored for future use, make certain that they are stored in proper containers that allow for protection against contamination, and kept in a clean area of moderate temperature reading. For information on storing the machine package for periods of non-use, consult *Section 5.6.2, Long Term Storage*.

## 5.5 PARTS REPLACEMENT AND ADJUSTMENT PROCEDURES



### WARNING

Relieve pressure from the compressor system before performing maintenance on any components.



### WARNING

Before performing maintenance or repair operations on the machine, ensure that all power has been removed and locked out to prevent accidental start-up.



### CAUTION

Always wear personal protective equipment such as gloves, safety shoes or boots, eye, and hearing protection as required for the task at hand.



### CAUTION

Compressors and engines generate heat and create hot surfaces. Use caution when operating or servicing equipment. Some surfaces and components may be hot.

### NOTE

Refer to the Engine Owner's Manual for detailed maintenance and replacement procedures for the engine.

### NOTE

Inspect and replace damaged components before operation with Air N Arc Replacement Parts. Using replacement parts other than Air N Arc Replacement Parts will void the warranty.

### 5.5.1 ADJUSTING COMPRESSOR CUT-IN / CUT-OUT PRESSURE

The **Cut-in pressure** is defined as the pressure in which the compressor starts pumping. Anytime the pressure in the tank falls below this pressure the compressor is allowed to start pumping.

The **Cut-out pressure** is defined as the pressure in which the compressor stops pumping. When the pressure in the air tank rises above this pressure the compressor is signaled to stop pumping.

Pressure settings for both the minimum and maximum rated pressure levels for this machine are adjusted at the factory before shipping, and should not need to be adjusted. However, a situation may occur where it is necessary to manually adjust or reset either or both of these settings. For such cases, consult the following procedure.

Refer to **Figure 5-1**. Locate the pilot valve on the base frame, near the compressor unit, and use the following procedure to make adjustments.



#### WARNING

**Relieve pressure from the compressor system before performing maintenance on any components.**

1. With a marker or scoring object, make a corresponding mark [F] on the pressure adjustment screw [B], pressure differential adjustment nut [D], and the valve body [E] for referential purposes.
2. With the machine off, loosen the locknut [C], and adjust the pressure adjustment nut clockwise (in) to raise the cut-in/cut-out pressure, and counter-clockwise (out) to lower the cut-in/cut-out pressure. Using the reference mark made in Step #1, adjust the pressure adjustment nut by a 1/4 - 1/2 turn interval, and tighten the locknut.

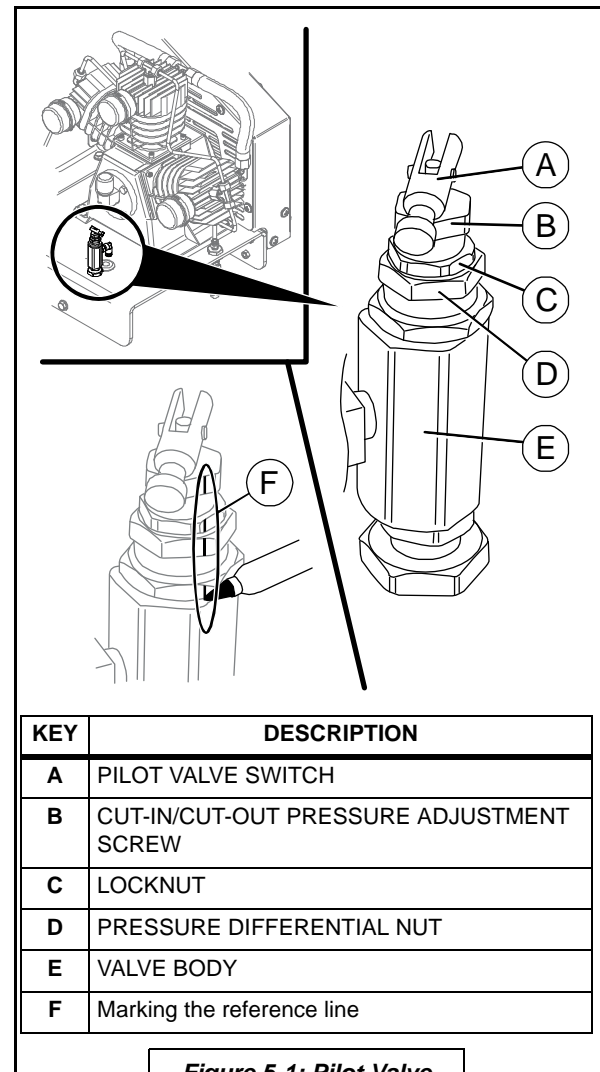

**Figure 5-1: Pilot Valve**

3. Start the engine and check the air pressure gauge reading after the engine has returned to idle speed.
4. Repeat Steps #2 and #3 if further adjustment is needed.

#### NOTE

**DO NOT adjust the factory set pressure differential adjustment nut. Reference the mark made on the pressure variation adjustment nut, and the valve body to insure that it has not changed position.**

### 5.5.2 ADJUSTING THE ENGINE SPEED

#### NOTE

**DO NOT tamper with the governor setting to increase the maximum engine speed. Overspeed is hazardous and will void the engine warranty. The maximum allowable high idle speed no load for the engine is 3700 RPM.**

### 5.5.3 REPLACING AND RE-TENSIONING THE COMPRESSOR AND/OR GENERATOR DRIVE BELTS



#### WARNING

**Relieve pressure from the compressor system before performing maintenance on any components.**



#### WARNING

**Before performing maintenance or repair operations on the machine, ensure that all power has been removed and locked out to prevent accidental start-up.**

The engine drives the compressor and the generator via the use of two drive belt types. The compressor utilizes a poly link, chain-type belt, whereas the generators are driven by a serpentine v-belt. The belts are designed for long life, but should periodically be checked for damage and replaced if visibly damaged. In addition, over time they become loose and need to be tightened. Consult **Section 5.5.3.3** for instruction on how to check the compressor belt(s) tension.

#### 5.5.3.1 ACCESSING THE DRIVE BELTS - REMOVING THE BELT GUARD SHIELD

The belt guard must be removed to access the drive belts. The Air N Arc 150 Series system utilizes a poly link series v-belt to drive the compressor unit, and a serpentine v-belt to drive the generator system. Refer to **Section 7.7, Belt Guard Assembly** (parts

**#1, #2 and #15)** and the following procedure to access the drive belts:



#### WARNING

**Never under any circumstances operate the machine with the belt guard removed. When performing service with the belt guard removed, always ensure that the negative battery cable is disconnected.**

1. Disconnect the battery ground cable.
2. Remove the seven (7) truss head screws and washer pairs securing the outer shield guard to the frame.
3. Remove the shield and place it in a safe location.

#### 5.5.3.2 REPLACING THE BELT GUARD SHIELD

Replace the belt guard in reverse order of removal.

#### 5.5.3.3 RE-TENSIONING THE AIR COMPRESSOR DRIVE BELT

The poly link v-belt used for the compressor drive does not require a separate tensioner. Rather, the belt is directly sized by the amount of links in the belt. Proper tension on a poly link v-belt is 3/8" to 1/2" give. Consult **Figures 5-2, 5-3, 5-4**, and the following procedure:



#### IMPORTANT

**The compressor drive belt is tensioned by the number of links in the belt. Never attempt to adjust the compressor belt tension by repositioning either the compressor unit or the engine from its mounted position, as these components are alignment-set at the factory.**

1. With the machine off and the ground wire disconnected from the battery, remove the belt guard shield per **Section 5.5.3.1**.

2. Check the deflection of the belt for looseness by applying pressure with a finger at the center location between the pulleys, as shown in **Figure 5-2**. The “give” should be in the range of 3/8 to 1/2 inch for each belt.

**COMPRESSOR DRIVE BELT REMOVAL**

3. If any number of links needs to be removed, or if the belt needs to be replaced, then belt must first be removed from the pulleys.

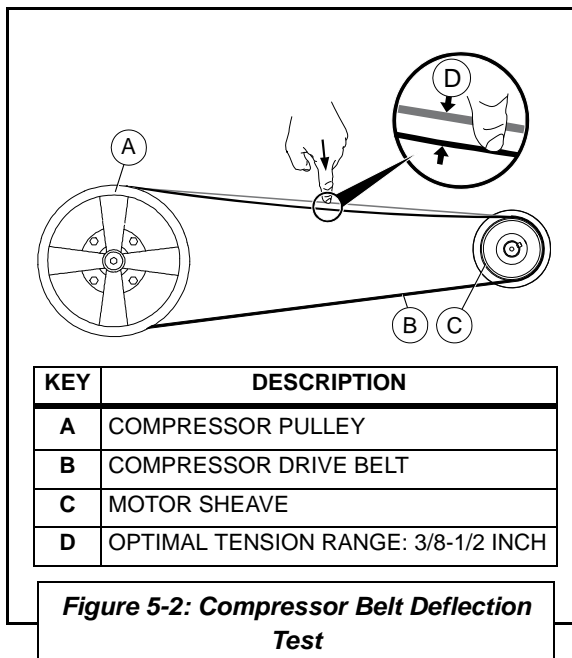

Refer to **Figure 5-3** For belt removal, grip the outer belt with the right hand while twisting the belt outward [A], and manually rotate the compressor pulley with the left hand [B]. The belt will slide free.

4. If belt is too loose, then it will need to be resized. Consult

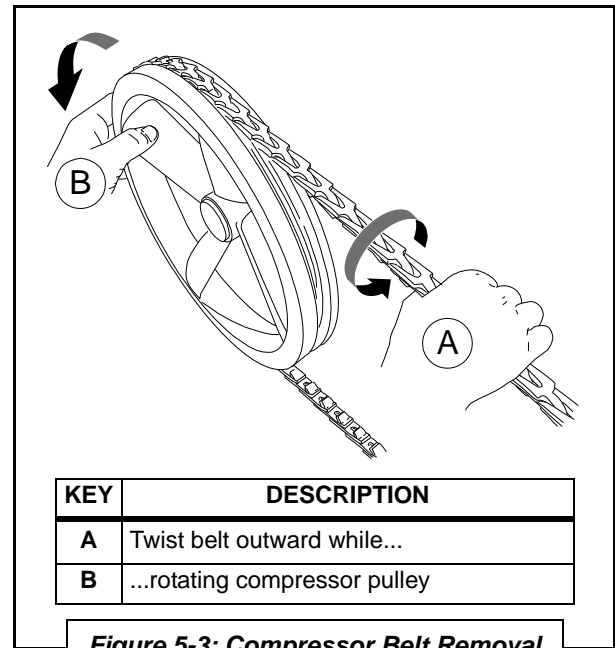

Section 5.5.3.4 to re-size a poly link belt.

**5.5.3.4 COMPRESSOR BELT SIZING**

When sizing a new compressor drive belt, first remove the worn belt as explained in **Section 5.5.3.3**, Step #3 and Step #4. Then consult **Figure 5-4** and the following procedure:

**⚠ IMPORTANT**

Over-tightening the compressor poly-link belt will result in overloading of the compressor and engine bearing and belt failure, while a loose belt will be slipping and result in an unstable speed, overheating of the belt, and premature belt failure.

**NOTE**

Every tenth link is designated with an arrow of direction ([D] in Figure 5-4).

The poly link belt is placed so that the tab ends of the links are facing inward, toward the pulleys.

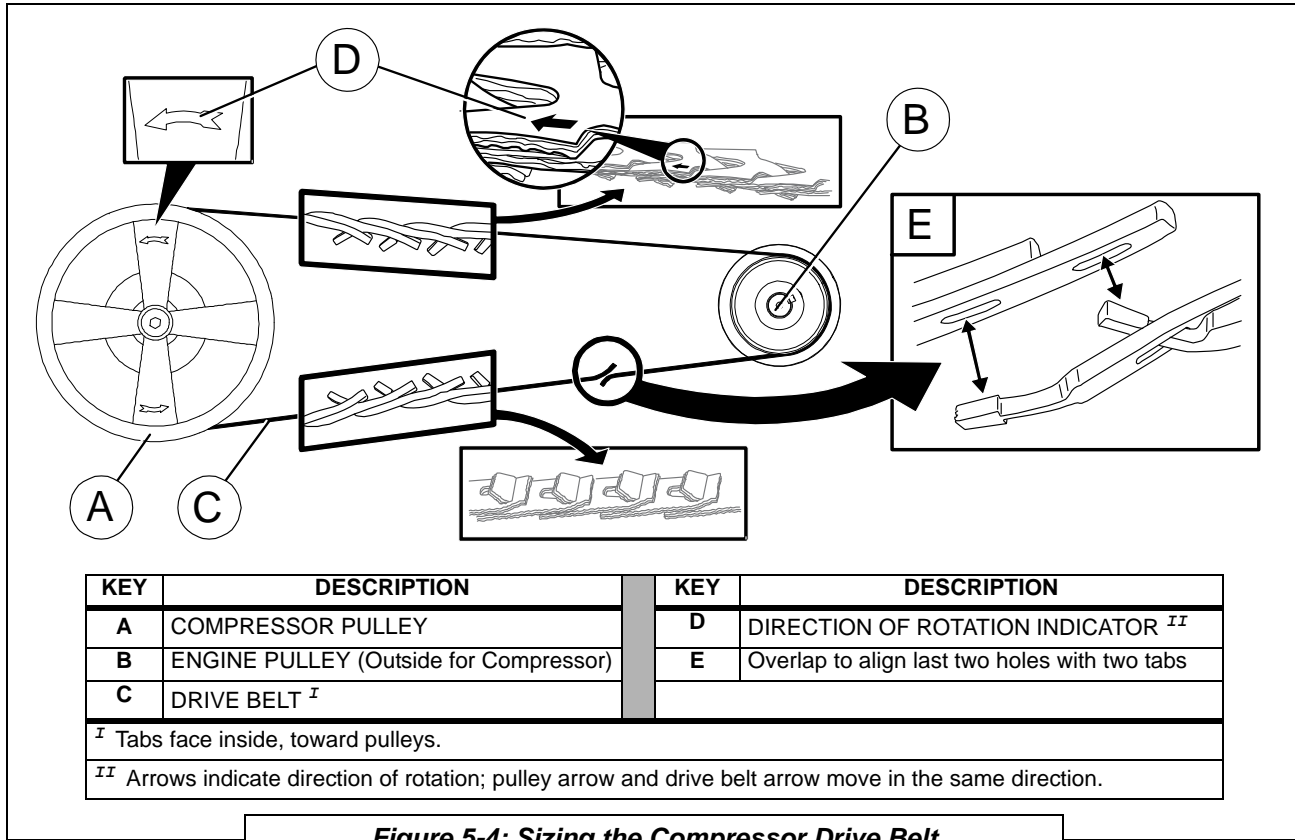

Wrap new belt as shown in **Figure 5-4**, and pull it tight around the pulleys, ensuring that the arrow indications on the belt face the same direction as the compressor pulley arrow(s).

5. To determine the length, overlap the last two holes of one end of the belt with two tabs of the other end, matching links as shown in [E].
6. Use a marker to place an identifying mark where the excess link begins.
7. Once the belt is sized correctly, the excess overlapping link(s) will need to be removed before assembling the sized belt into a completed loop. Follow the procedure given in **Section 5.5.3.6, Compressor Belt Assembly**.

### 5.5.3.5 COMPRESSOR BELT LINK DISENGAGEMENT

Refer to **Figure 5-5**, and the following procedure:

1. Hold belt tab-side up with one hand; bend back as far as possible to expose tab [B<sub>1</sub>].
2. With the tab now turned parallel to the slot, push down on the tab [C] while pulling up on the link's end [D].
3. Rotate the belt end with tab [B<sub>2</sub>] so that the tab is turned parallel to the slot.
4. Push down on the tab [F], while pulling up on the link's end [G].

### 5.5.3.6 COMPRESSOR BELT ASSEMBLY

Once the proper length of the belt has been determined (refer to **Section 5.5.3.4**), and



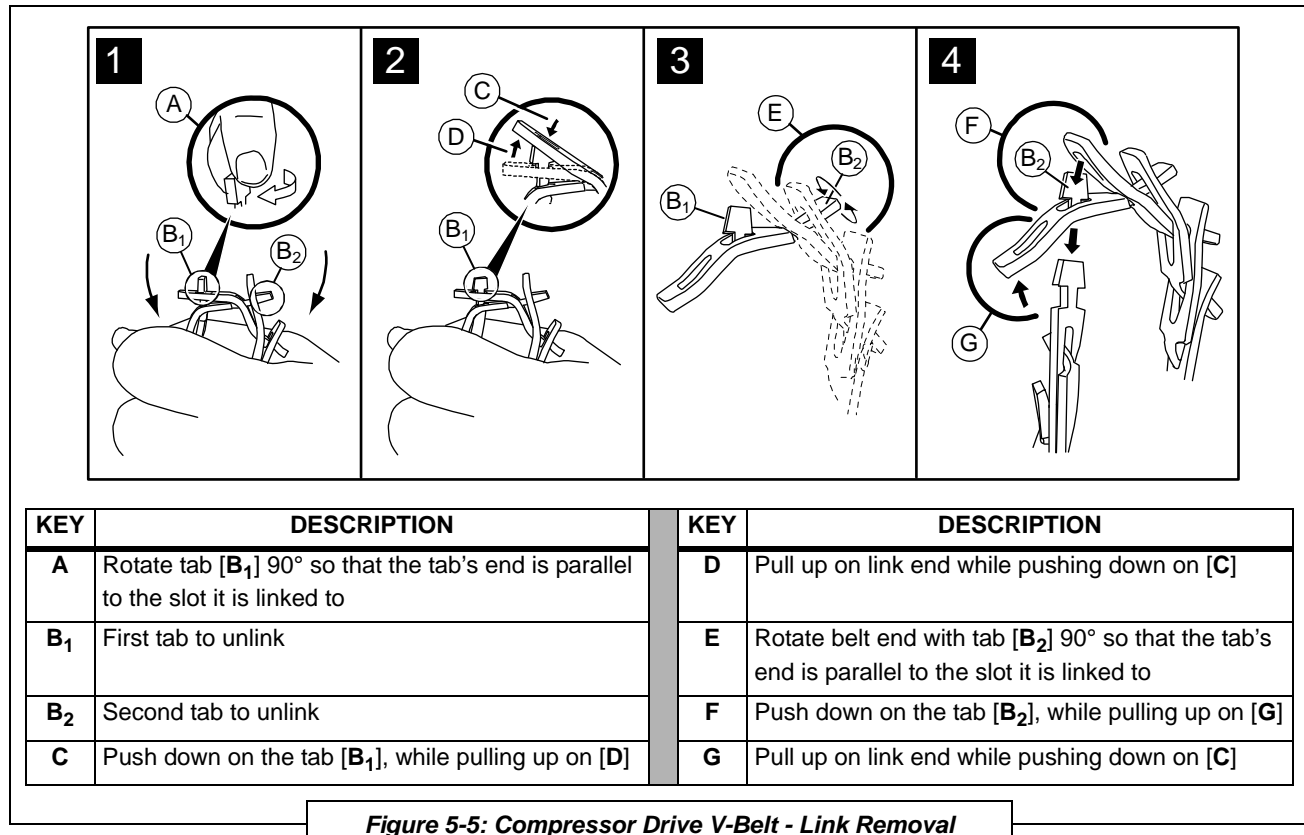

**Figure 5-5: Compressor Drive V-Belt - Link Removal**

the belt is shortened to its fitted length (refer to **Section 5.5.3.5**), then the belt's ends are linked together to form the completed belt loop. Refer to **Figure 5-6**, and the following procedure:

1. Place tab [A] corner against the inside of the link hole [B] (nearest to thumb [D]).
2. With thumb [C], push on the tab's edge in the direction indicated.
3. Simultaneously with Step #2 above, push on link end [B] with thumb [D] in the direction indicated. **NOTE:** Inset [E] shows how the pressure applied from both thumbs causes the tab to "rotate" toward the slot position.
4. When tab is positioned parallel with the slot, push it/pull it through the slot.

5. After the tab is through the slot, twist it 90°, as shown in [F], to secure it into place.

### 5.5.3.7 TRACKING COMPRESSOR BELT ONTO PULLEY GROOVE

Refer to **Figure 5-7** and the following procedure to mount the compressor link drive belt onto the compressor and engine pulleys.

1. Make certain that the belt is sized correctly before setting it into place on the pulleys. Consult **Sections 5.5.3.4** through **5.5.3.6** to size and assemble the belt.
2. The belt should be linked as a completed loop prior to setting it onto the pulley tracks. Run belt around the proper belt groove on the engine pulley (compressor belt tracks to *outside* engine pulley), taking care that the belt's

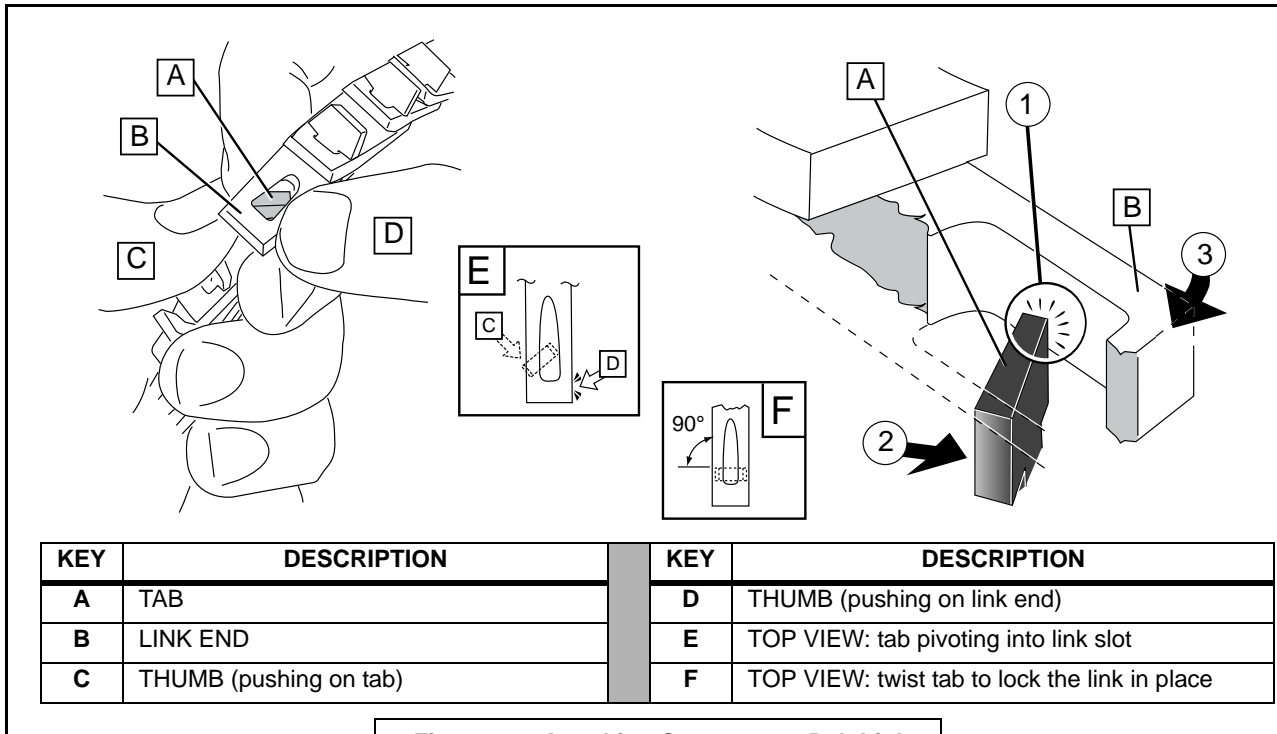

Figure 5-6: Attaching Compressor Belt Link

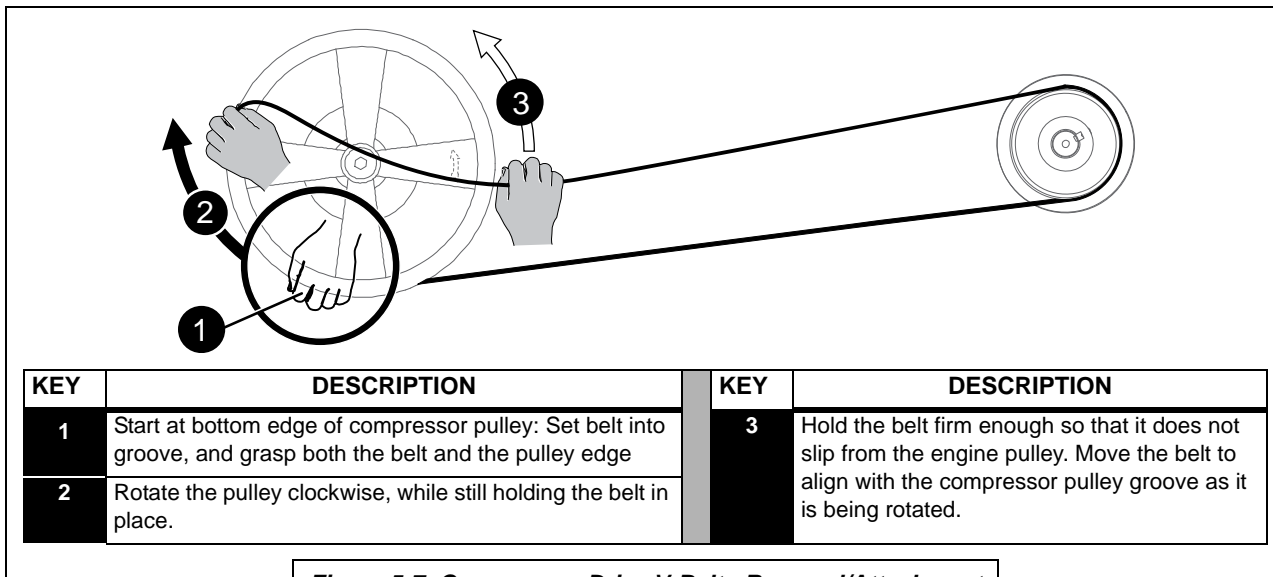

Figure 5-7: Compressor Drive V-Belt - Removal/Attachment

tabs are facing inward toward the pulley, and the arrows on the belt point in the same direction as the arrow of rotation on the compressor pulley (see **Figure 5-4 [D]**).

3. Start at the bottom edge of the pulley as per **Figure 5-7, Step #1**. Continue to set the belt into the proper groove on the compressor pulley and engine pulley.

4. After the belt is seated into the compressor pulley groove, hold the belt and the pulley with the left hand (**Figure 5-7, Step #2**), while rotating the pulley in the direction shown. At the same time, feed the belt upward with the right hand as the pulley is turned (**Figure 5-7, Step #3**).

The belt will slip into place once the left hand, which is holding the belt, reaches near the top of the compressor pulley.

### 5.5.3.8 RE-TENSIONING OR REPLACING THE GENERATOR SERPENTINE BELT

The generators are driven by the engine using a serpentine belt. This belt has a spring tensioner end that will generally not need to be re-tensioned during the service life of the generator system. However, over time it may become loose and need to be tightened. The proper tension can be determined by using a tension tester to measure the deflection from a given force.

The belt guard must be removed to access the drive belt. The 150 Series system utilizes a single serpentine v-belt to drive the generator system. **Consult Section 5.5.3.1, Accessing the Drive Belts**, for instructions on how to remove the belt guard.

### 5.5.3.9 RE-TENSIONING THE GENERATOR SERPENTINE BELT

To re-tension the generator serpentine belt, consult **Figure 5-8**. Once the generator drive belt is established onto the engine, generator and idler pulleys, the spring tensioner on the idler pulley will self-adjust the belt. There is no additional adjustment required.

### 5.5.3.10 REPLACING THE GENERATOR SERPENTINE DRIVE BELT

In order to replace the generator serpentine belt, the compressor belts will need to be removed. Consult **Section 5.5.3.3, Steps #3 and #4** to remove the compressor belts.

To replace the generator serpentine belt, refer to **Figure 5-8** and the following procedure:

1. With the machine off, the ignition key removed, the positive (+) battery cable disconnected from the battery, and the compressor v-belt removed, the worn generator serpentine belt can now be replaced.
2. Loosen the generator belt by performing the procedure given in **Section 5.5.3.9, Re-Tensioning the Generator Serpentine Belt**.

By loosening the tensioner plate bolt (item [C] in **Figure 5-8**), and pivoting the generator idler sheave assembly to its maximum position, the generator belt will be loosened enough to remove it from the generator and engine drive pulleys.

3. Run a new serpentine belt into place about the generator, engine and idler pulleys as shown in **Figure 5-8**. Keep in mind when tracking the belt that the tread-side faces the inside of the driver pulleys, as shown in item [F].
4. After the belt has been situated onto each track groove on the generator and engine drive pulleys and the idler, the tension will need to be reset via the position of the idler sheave assembly, and checked.
5. After the generator serpentine belt has been set and checked, the compressor drive belt needs to be repositioned on the pulleys. Consult **Section 5.5.3.7, Tracking Compressor Belt Onto Pulley Groove** to reset the compressor drive belt. Refer to **Section 5.5.3.3, Re-tensioning the Compressor Drive Belt** to assure that the compressor belt is properly tensioned.

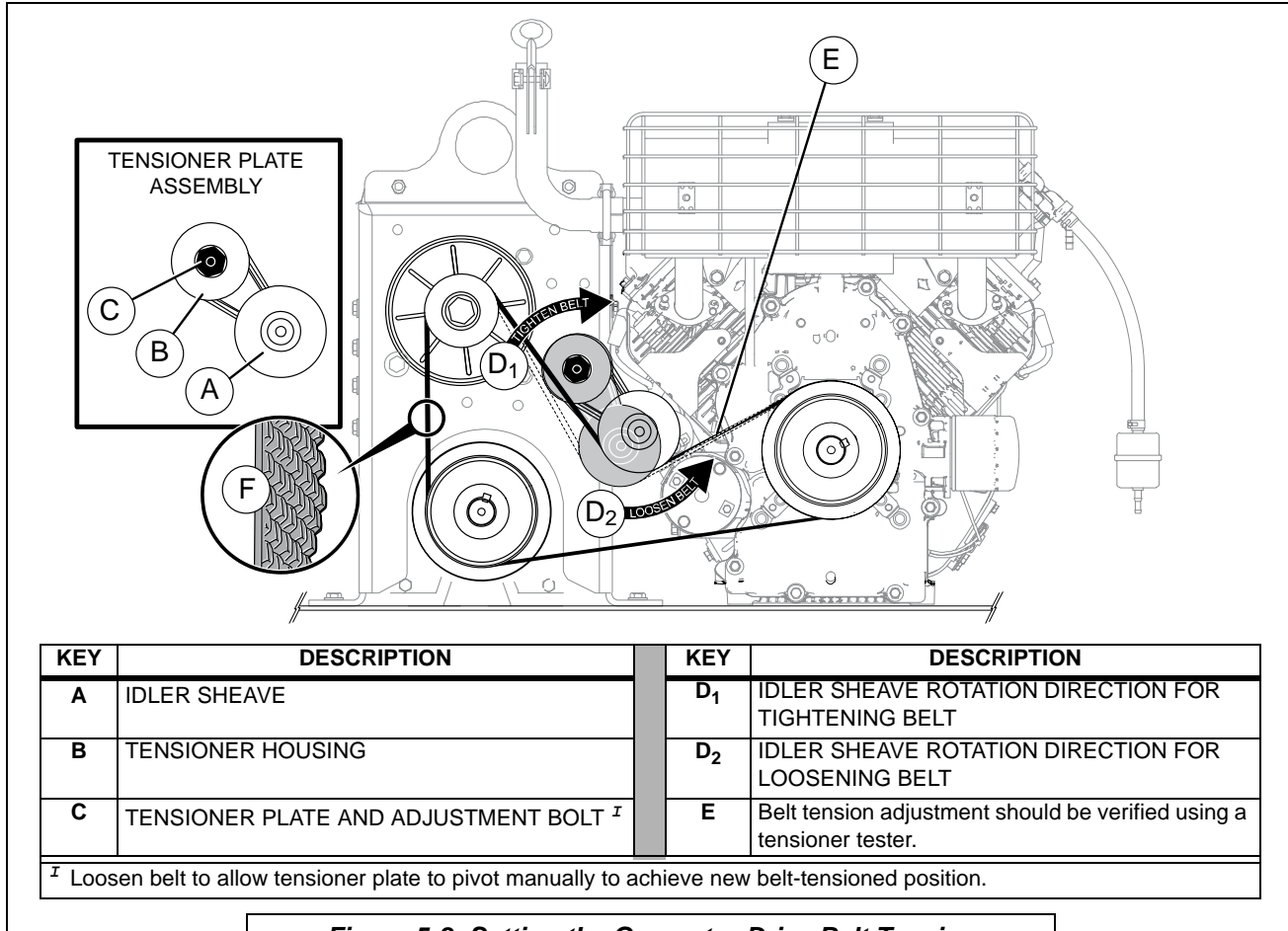

**Figure 5-8: Setting the Generator Drive Belt Tension**

- After the compressor belt has been reset and its tension confirmed, replace the belt guard shield as per **Section 5.5.3.2, Replacing the Belt Guard Shield**.

Refer to **Figure 5-9**. The replaceable engine 25A fuse is located within the engine ignition housing.

Replacement fuses can usually be found at local vendor carriers such as automobile supply stores, hardware stores, etc. Refer to the following procedure to change the fuse:

**5.5.4 SERVICING THE FUSE**

**⚠ DANGER**

The fuse will need to be replaced if it is blown when tripped. When changing the fuse, or dealing directly with any function of the electrical system maintenance, always be aware of the safety warnings given in *Section 1, Safety*.

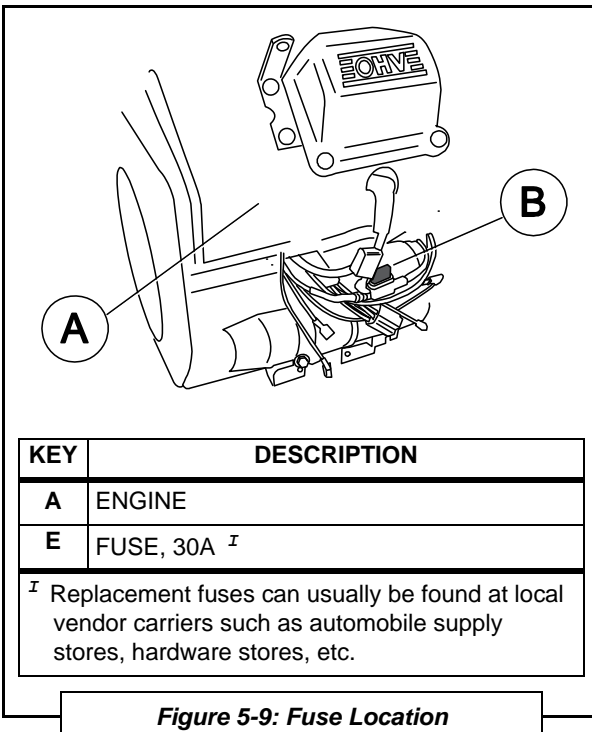

1. Remove the bolt [A] and washer [B] from the rear-side of the engine ignition housing [C].
2. Locate the fuse housing and open the cap to expose the fuse.
3. Remove the blown fuse [E], and replace with new fuse.
4. Replace the fuse housing cap to secure the fuse.

5. Replace the rear-side ignition housing onto the front-side ignition housing [C].
6. Secure into place with the washer and bolt.

## 5.6 STORAGE AND INTERMITTENT USE

### 5.6.1 INTERMITTENT USE

If the unit is not used very regularly always treat the fuel with a fuel stabilizer.

Check all belts and hoses for signs of deterioration such as visible surface cracks, stiffness or discoloration.

### 5.6.2 LONG TERM STORAGE

Disconnect the battery cable that is connected to the positive (+) side of the battery.

Depressurize the air tank and open the drain valve on the tank.

Cover the unit with a tarp or plastic to prevent the accumulation of dust, but leave the bottom open for air circulation.

Fill gas tank with fuel and fuel stabilizer to prevent moisture build-up in the tank.

**BLANK PAGE**

# SECTION 6: TROUBLESHOOTING

## 6.1 GENERAL INFORMATION

The information contained in this section has been compiled from years' worth of information gathered from the field. It contains symptoms and usual causes for the most common types of problems that may occur. All available data concerning the trouble should be systematically analyzed before undertaking any repairs or component replacement.

A visual inspection is worth performing for almost all problems and may avoid unnecessary additional damage to the machine. The procedures which can be performed in the least amount of time and with the least amount of removal or disassembly of parts, should be performed first. Adherence to a routine maintenance regimen will minimize the occurrence of many common problems. Refer to **Section 5.3, Maintenance Schedule Table** for a typical maintenance regimen program.

Although Vanair® strives to anticipate situations that may occur during the operation life of the machine package, the **Troubleshoot-**

**ing Guide** may not cover all possible situations. Be aware that additional troubleshooting information may be found in other sources such as the Engine Owner's Manual. Should the situation remain unresolved after exhausting available sources, contact your local dealer or the Vanair Service Department.

	<b>WARNING</b>
<p><b>DO NOT</b> operate any of the Air N Arc 150 Series machine's functions if there is a known unsafe condition. Disable the equipment by disconnecting it from its power source. Install a lock-out tag to identify the equipment as inoperable to other personnel to prevent accidental application.</p>	

	<b>WARNING</b>
<p>Before starting, performing maintenance, or replacing parts, relieve the entire system pressure by opening the air tank drain valve, which will vent all pressure to the atmosphere.</p>	

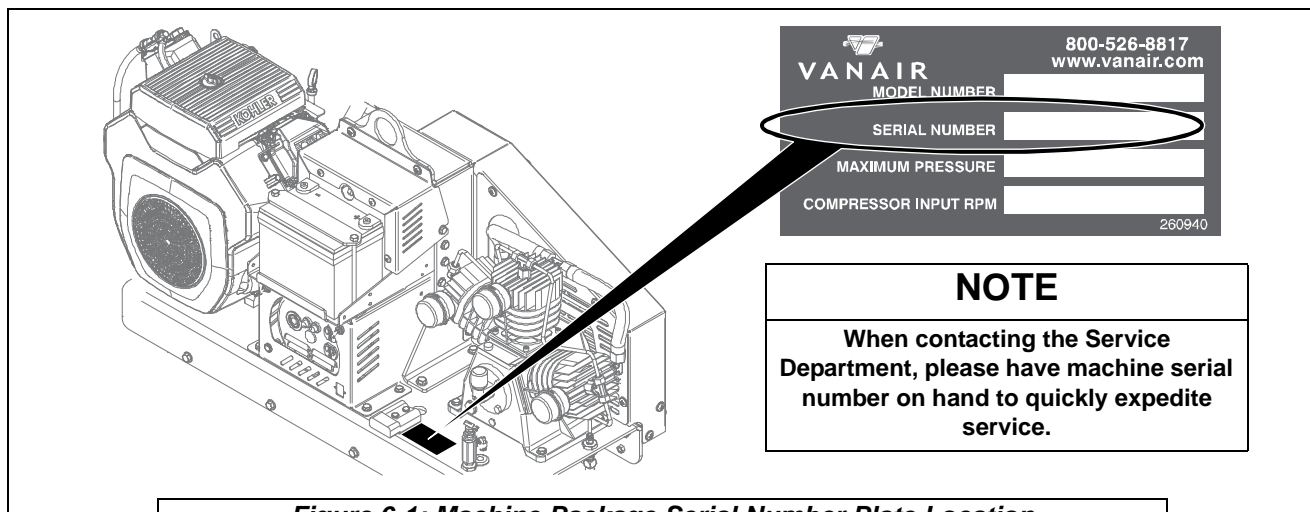

**Figure 6-1: Machine Package Serial Number Plate Location**

<b>NOTE</b>
<p>When contacting the Service Department, please have machine serial number on hand to quickly expedite service.</p>

<b>6.2 TROUBLESHOOTING GUIDE</b>		
<b>Fault/Malfunction</b>	<b>Possible Cause</b>	<b>Corrective Action</b>
<b>ENGINE</b>		
<i>For additional information concerning the engine, consult the Engine Owner's Manual</i>		
Engine will not crank	Faulty battery connection.	Check for proper battery connections and battery charge.
	Battery out of power	Recharge or replace battery.
	Engine fuse blown or faulty	Check engine fuse (consult the Engine Owner's Manual).
	Engine seized	Replace engine.
	Faulty starter	Replace starter.
	Faulty starter connection	Check for proper electrical connections at starter.
	Poor ground connection	Check and clean/renew connection.
	Faulty starting solenoid	Replace solenoid.
Engine will crank, but not start	Low fuel and/or oil supply	Check fuel gauge. Check engine oil level; replenish as necessary. Refer to the Engine Owner's Manual for additional information on engine maintenance.
	Pinched fuel line	Replace or reroute if necessary.
	Plugged fuel filter	Replace if necessary. Refer to the Engine Owner's Manual for additional information on engine maintenance.
	Low battery voltage	Recharge or replace if necessary.
		Loose connections; tighten connections.
		Dirty connections; clean connections.
	Plugged engine air filter	Replace engine air filter. Refer to Engine Owner's Manual.
	Poor ground connection	Check and clean/renew connection.
	Faulty spark plug	Check spark plug and replace if necessary. See Engine Owner's Manual.
	Engine choke not operating properly	Check engine choke position.
	Faulty starter motor (slow crank)	Replace starter.
Carburetor faulty	Repair or replace carburetor.	
Improper Control Operation: Engine does not speed up	Throttle solenoid stuck	Check throttle solenoid. Replace if necessary.
		Check throttle relay; replace if necessary.
	Governor stuck	Free governor and lubricate if necessary.

**Continued on next page**



## 6.2 TROUBLESHOOTING GUIDE

Fault/Malfunction	Possible Cause	Corrective Action
<b>ENGINE (CONTINUED)</b>		
Improper Control Operation: Engine does not speed up (cont.)	Fuel filter partly plugged	Replace fuel filter. Refer to the Engine Owner's Manual.
	Faulty pilot valve	Readjust or replace pilot valve.
	Faulty pressure switch	Replace pressure switch.
Improper Control Operation: Engine does not slow down	Leak in control line	Check for leaks; replace line if necessary.
	Pilot valve out of adjustment or malfunctioning	Pressure settings may need to be reset.
	Faulty pressure switch	Replace pressure switch.
	Throttle solenoid stuck	Check throttle solenoid. Replace if necessary. Check throttle relay; replace if necessary.
	Governor stuck	Free governor and lubricate if necessary.
Engine overheats	Located too close to obstruction.	Move further from obstruction.
	Low oil level	Check engine oil level; Refer to the Engine Owner's Manual; replenish as necessary.
	Restricted cooling air in or out	Clean engine intake grill.
	RPMs too fast	Adjust speed.
Engine stops during operation	Low oil level	Check engine oil level; Refer to the Engine Owner's Manual; replenish as necessary.
	Low fuel	Check fuel gauge. Fill as necessary.
	Engine overloaded	Reduce demand/Turn off one function.
	Engine idle set too low	Adjust idle to proper speed.
	Fouled spark plug	Check spark plug and replace if necessary. Refer to the Engine Owner's Manual.
Engine will not throttle up for various functions	Faulty throttle solenoid	Check throttle solenoid; replace if necessary.
		Check throttle relay; replace if necessary.
	Blown system fuse	Check system fuse; replace if necessary.
	Faulty pilot valve	Replace pilot valve.
	Faulty pressure switch	Replace pressure switch.
Gradual loss of engine power	Contaminated fuel	Drain and replace fuel supply.
	Wrong fuel type fill	Use only gasoline—do not use E85, etc. Refer to Engine Owner's Manual for information on engine fuel type to use.

*Continued on next page*

## 6.2 TROUBLESHOOTING GUIDE

Fault/Malfunction	Possible Cause	Corrective Action
<b>ENGINE (CONTINUED)</b>		
Gradual loss of engine power (continued)	Engine air filter contaminated	Check air filter. Replace if necessary (refer to the Engine Owner's Manual).
	Fuel filter contaminated	Check fuel filter. Refer to the Engine Owner's Manual for additional information on engine maintenance.
	Vapor lock	Machine overloading. Allow to cool.
		Refer to "Engine overheats" section in this Troubleshooting Guide.
	Fouled spark plug	Check spark plug and replace if necessary. Refer to Engine Owner's Manual.
	Engine choke not operating properly.	Check engine choke position.
	Carburetor faulty	Repair or replace carburetor.
Fuel pump weak	Replace fuel pump.	
<b>COMPRESSOR</b>		
Compressor overheats	Low compressor oil level	Check oil level and refill to proper level if necessary.
	Obstructed or restricted intake air flow	Check for obstructions (frame, body, etc.) to air filter vents. Replace air filter if necessary.
	Unloader valve(s) sticking or faulty	Clean or rebuild/replace.
	Dirty compressor, head, cylinder or intercooler	Clean with compressed air.
	Operating pressure too high.	Reduce operating pressure.
	Incorrect oil being used.	Drain and replace oil.
	Compressor cycle too long. (Proper cycle is 50-60% on Stop/Start operation and 75-80% on continuous run operation.	Allow for longer rest period between cycles.
Compressor will not build up pressure	Compressor system is not receiving enough operating power	If running more than one function simultaneously, turn off competing function
	Air demand too high	Check for leaks and take corrective action.
		Check air tools for wear, damage, or malfunctions. Replace or repair.
<i>Continued on next page</i>		

## 6.2 TROUBLESHOOTING GUIDE

Fault/Malfunction	Possible Cause	Corrective Action
COMPRESSOR (CONTINUED)		
Compressor will not build up pressure (continued)	Drain cock open	Close drain cock.
	Pilot valve out of adjustment or malfunctioning	Pressure settings may need to be reset. Refer to <b>Section 5.5.1, Adjusting Compressor Cut-in / Cut-out Pressure.</b>
	Obstructed or restricted intake air flow	Check for obstructions (frame, body, etc.) to air filter vents. Replace air filter if necessary.
	Belt(s) slipping or broken	Re-situate and adjust belt tension, or replace belt if necessary. Consult <b>Section 5.5.3, Replacing and Re-tensioning the Compressor and/or Generator Drive Belts.</b>
	Engine governor stuck	Free governor and lubricate if necessary. Consult the Engine Owner's Manual.
	Unloader valve(s) sticking or faulty	Clean or rebuild/replace.
	Pressure relief valve not operating properly	Replace if necessary.
	Leak in air system	Inspect air system for leaks.
	Faulty throttle solenoid	Check throttle solenoid; replace if necessary. Check throttle relay; replace if necessary.
	Input rpm too low	Adjust to proper setting.
	Service valve is open	Close service valve.
	Pressure gauge is malfunctioning	Check pressure gauge function/control line routing: adjust, repair or replace as necessary. Check for proper operation with an auxiliary air source. Replace if necessary.
	Compressor incorrectly sized	Match task requirements within the compressor specification range.
	Head gasket leaking	Replace head gasket.
	Dirty or plugged inter-cooler tubes	Remove and clean inter-cooler tubes.
	Worn or defective compressor valves	Replace worn parts.
	Worn piston, worn out rings	Replace worn parts.

*Continued on next page*

## 6.2 TROUBLESHOOTING GUIDE

Fault/Malfunction	Possible Cause	Corrective Action
<b>COMPRESSOR (CONTINUED)</b>		
Excessive moisture in the compressed air	Moisture accumulating in air tank	Drain water from air tank. Refer to <b>Section 5.3, Maintenance Schedule Table</b> , and <b>Section 7.15A - 7.15C, Installation and Dimension Diagram</b> .
	Excessive compressor heat	Allow compressor to cool down.
Compressor system over-pressures	Damaged/kinked control line	Check line for damage (wear, kinks, etc.). Re-route, re-tie or replace if necessary.
	Restriction in control line	Clean if soiled; if ice is present, clear and remove.
	Control line connections are not properly seated/poor connection quality	Check lines for proper seating/ensure line ends have been cut cleanly and are square ( <b>DO NOT</b> use wire cutters: use a loom cutting tool or a clean, sharp razor blade).
	Pilot valve out of adjustment or malfunctioning	Pressure settings may need to be reset.
	Unloaders stuck	Lubricate
	Pressure gauge is malfunctioning	Check for proper operation with an auxiliary air source. Replace if necessary.
		Check pressure gauge function/control line routing: adjust, repair or replace as necessary.
Defective safety valve	Replace safety valve.	
No service air output	If equipped, OSHA valve/velocity fuse, not functioning properly	Reset or replace OSHA valve.
	Belt(s) not adjusted properly, worn or slipping/belt broken	Belt(s) out of position or malfunctioning. Consult <b>Section 5.5.3, Replacing and Retensioning the Compressor and/or Generator Drive Belts</b> .
	Bad discharge check valve	Replace check valve.
Low service air output	Clogged compressor air filter	Check air filter. Replace if necessary.
	Pilot valve sticking	Replace pilot valve.
	Incorrect compressor speed	Adjust speed.
	Discharge OSHA check valve	Replace check valve.
	Unloaders stuck	Repair or replace unloaders.
<i>Continued on next page</i>		

<b>6.2 TROUBLESHOOTING GUIDE</b>		
<b>Fault/Malfunction</b>	<b>Possible Cause</b>	<b>Corrective Action</b>
<b>COMPRESSOR (CONTINUED)</b>		
Excess amount of oil in air discharge	Compressor oil level too high	The correct oil level is the half-way mark on the sight glass with the compressor shut down, and the machine on a level surface. Drain excess oil to correct level.
	Compressor overheated/air pressure rpms regulated too high	Adjust air pressure rpms.
	Restricted air filter	Clean or replace air filter.
	Improper oil viscosity	Drain and replace oil.
	Worn piston rings	Replace piston rings.
Water in crankcase Oil breaking up Oil gets dirty; rusty valve or cylinder	Cycle too short; compressor does not operate long enough to vaporize condensed moisture during compression.	Allow for a longer operating cycle.
	Compressor operating outside in cold conditions or inlet filter not protected against weather.	Provide adequate protection against extreme weather conditions. Refer to <b>Section 6.3, Extreme Condition Operation.</b>
	System pressure leaking back through check valve when compressor is stopped	Check and replace/check valve, if necessary.
	Wrong oil being used	Drain and replace with proper oil.
Excessive vibration	Loose compressor, motor, engine or guard	Tighten components.
	Excessive discharge pressure	Reduce operating pressure.
	Compressor not level	Level compressor.
	Wrong oil being used	Drain and replace with proper oil.
	Loose flywheel, drive pulley or drive belts	Tighten loose components and check belts.
	Worn rods, wrist pin or main bearings	Check and replace worn parts.
Compressor knocks	Compressor valves loose or broken	Check and replace worn or broken valves.
	Inspect check valve; it may knock at low pressures	Remove and clean check valve.
	Bearing failure	Replace compressor.
<i>Continued on next page</i>		

## 6.2 TROUBLESHOOTING GUIDE

Fault/Malfunction	Possible Cause	Corrective Action
<b>COMPRESSOR (CONTINUED)</b>		
Compressor uses too much oil	Clogged inlet filter	Clean inlet filter or replace, if necessary.
	Wrong oil being used; wrong viscosity	Drain and replace oil.
	Oil level too high	Fill compressor with oil to proper level.
	Crankcase breather valve malfunction	Replace crankcase breather.
	Compressor runs unloaded too long	Increase load or stop compressor when not needed. Check for air leaks.
	Compressor operating outside in cold conditions or inlet filter not protected against weather	Provide adequate protection against extreme weather conditions. Refer to <b>Section 6.3, Extreme Condition Operation.</b>
	Worn piston rings	Replace piston rings.
	Piston rings not seated	See <b>Piston rings not seated</b> instructions, below.
	Ample time not allowed for new rings to seat	Allow 100 hours of normal operation for new rings to seat.
<b>WELDER</b>		
Welder and/or battery charger behave erratically	Connection cables or receptacles are soiled/contaminated	Check for twisted cables and/or soiled/contaminated or loose receptacle connections.
		Untwist and/or straighten out any suspected cable tensions. Carefully wipe off any contaminants to receptacle connectors before re-connecting. Replace any worn or damaged cables or receptacles. Contact the Vanair Service Department if behavior persists.
	Welding function is not drawing enough operating power	If running more than one function simultaneously, turn off competing function.
No welder output Display not working	Fuse at welder field blown	Replace the welder field fuse.
	Loose or faulty wiring	Check wiring: If loose, secure; if faulty, replace.
	Bad welder	Replace welder.
Lights do not turn off	Battery charge low	Flip AC generator switch to bring engine to high rpm, and charge battery.
<i>Continued on next page</i>		

## 6.2 TROUBLESHOOTING GUIDE

Fault/Malfunction	Possible Cause	Corrective Action
<b>AC GENERATOR</b>		
No AC generator output	Circuit breaker tripped	Reset the circuit breaker.
	Capacitor failure	Replace capacitor.
	Loose or faulty wiring	Check wiring: Loose—secure; faulty—replace.
	Generator faulty	Replace generator.
Low AC voltage	Engine speed too low for demand	Adjust speed control. Refer to the Engine Owner's Manual.
	Capacitor failure	Replace capacitor.
	Wrong capacitor	Replace with higher rating cap.
High AC voltage	Engine speed too high for demand	Adjust speed control. Refer to the Engine Owner's Manual.
	Wrong capacitor	Replace with lower rating capacitor.

## 6.3 EXTREME CONDITION OPERATION

When operating in extreme hot or cold conditions, extra attention should be given to any indications that could lead to a serious problem. Machine review and maintenance check schedules should be more frequent than the normal suggestions given in **Section 5.3, Maintenance Schedule Table**.

Become familiar with the alternative operation procedures given in this section before operating the power system package in any type of extreme ambient conditions.

### 6.3.1 COLD WEATHER OPERATION

Additional care should be taken under consideration when operating the package in extreme cold weather environments or ambient temperatures.

Run machine with no load at full speed using the generator switch to warm up the machine (Refer to **Section 4, Figure 4-2 [A2]**).

### 6.3.1.1 ENGINE OPERATION

The standard recommendation of 10W-30 engine oil is suitable for temperatures down to -5°F. If temperatures are consistently below 30°F, it is recommended that 5W-30 oil be used. If temperatures are below -25°F, a high-performance, fully synthetic oil, such as AMSOIL 5W-30 should be used, which is suitable to temperatures of -55°F.

In below zero temperatures, a fuel line deicer product may need to be used.

Check the fuel filter regularly to insure that it contains no water.

Drain the moisture from the tank when it is warm from extended operation.

#### NOTE

**Ethanol blended fuels, such as E85, are prohibited for use with the Kohler engine. DO NOT use ethanol-based fuels. Consult Section 2, Specifications of this manual and the Engine Owner's Manual for acceptable fuel specifications.**

**NOTE**

**For additional information on engine operation, consult the Engine Operator's Manual.**

**6.3.2 HIGH TEMPERATURE OPERATION**

The standard recommendation of 10W-30 engine oil is suitable for operation in temperatures up to 110°F (43.3°C).

Extra care should be taken to keep the engine and air compressor clean and to not restrict the air flow around the unit.

**6.3.3 HIGH ALTITUDE OPERATION**

Engine horsepower will decrease by 3.5% for every 1,000 feet. increase in altitude. At high altitude overall unit performance will deteriorate, and care will need to be taken not to overload the engine by using more than one function of the unit.



# SECTION 7: ILLUSTRATED PARTS LIST

## 7.1 PARTS ORDERING PROCEDURE

Part orders should be placed through the distributor from whom the unit was purchased. If, for any reason parts cannot be obtained in this manner, contact the factory directly at the address or phone numbers listed to the right.

When ordering parts, always indicate the **Serial Number** of the machine package. This can be obtained from the Bill of Lading for the machine package, or from the compressor unit serial number plate. See **Figure 7-1** for location of machine package serial plate. Consult **Table 7A: Recommended Spare Parts List** on the next page for a listing of replacement parts.

### VANAIR® MANUFACTURING, INC.

10896 West 300 North

Michigan City, IN 46360

Telephone: (800) 526-8817

(219) 879-5100

Service: (844) VANSERV  
[844-826-7378]

Service Fax: (219) 879-5335

Parts Fax: (219) 879-5340

Sales Fax: (219) 879-5800

[www.vanair.com](http://www.vanair.com)

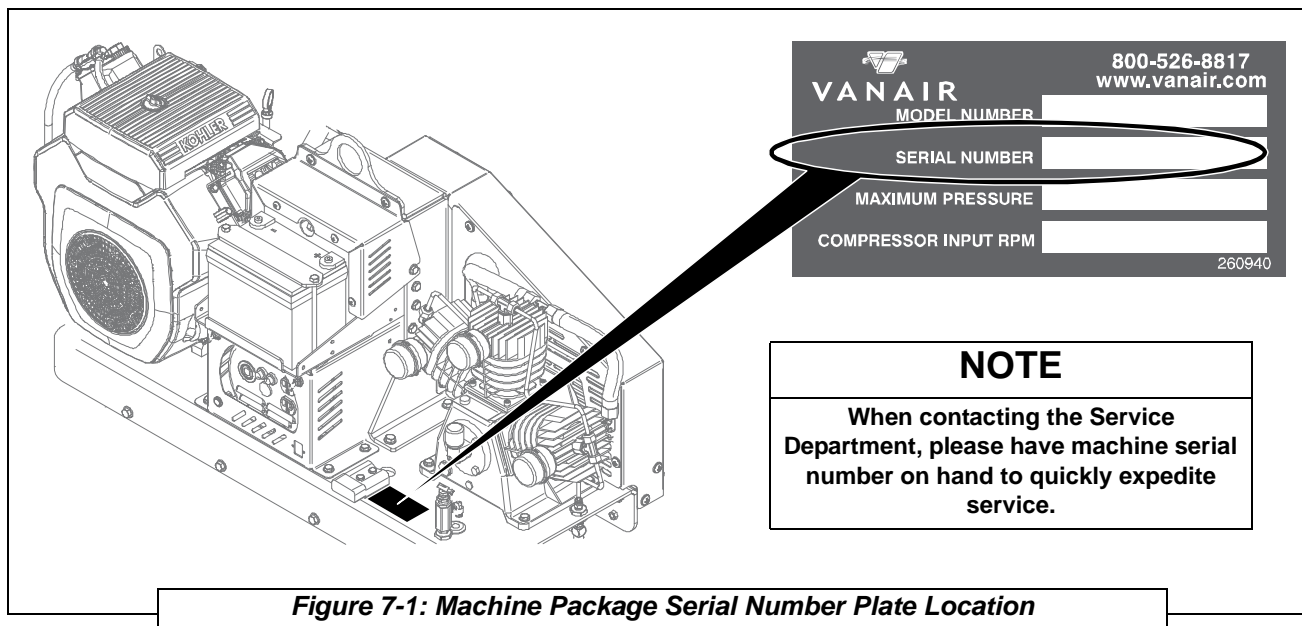

**Figure 7-1: Machine Package Serial Number Plate Location**

TABLE 7A: RECOMMENDED SPARE PARTS LIST			
KEY NO.	PART NUMBER	DESCRIPTION	QTY
1	271856-1QT	Vanguard™ Reciprocating Oil (quart container) <sup>I</sup>	1
2	CM271646-02	Filter, Element for Air Compressor <sup>II</sup>	3
3	CM271646-03	Gasket, Set for Compressor	1
4	CM271646-04	Unloader, Compressor Head	1
5	CM271646-05	Kit, Valve Repair for Compressor	1
6	CM271646-06	Kit, Ring Repair for Compressor	1
7	CM271646-07	Kit, Valve Plate Assembly for Compressor	1
8	CM271646-08	Kit, Discharge Tube	1
9	CM271646-09	Tube, Inner Stage	1
10	CM271646-10	Sight Glass for Compressor	1
11	CM271646-11	Head, Cylinder for Compressor	1
12	KIT1152	Kit, Full Service <sup>III</sup>	1
13	KIT1158	Kit, Engine Service <sup>IV</sup>	1
14	KIT 1216	Kit, Compressor	
15	CO47028	Gauge, Air, Dry 0-200 psi	1
16	PR81817	Boot, Breaker Panel Mount	2
17	v	Fuse, 25 Amp	1
18	CO62617	Circuit Breaker, 20 Amp for AC Generator	2
19	DR64616	Belt, Power Twist (compressor drive)	1
20	DR27026	Belt, Serpentine (generator drive)	1
<sup>I</sup> Compressor oil fill quantity is 24 ounces. Order one (1) quart.			
<sup>II</sup> Individual air filter part number is CM271646-01; take note that all three (3) air filters should be changed at the same time.			
<sup>III</sup> Kit includes: engine air filter, engine air pre-filter, engine fuel filter, spark plug, three (3) compressor air filters and one quart of reciprocating oil.			
<sup>IV</sup> Kit includes: engine air filter, engine air pre-filter, engine fuel filter and spark plug.			
<sup>v</sup> Replacement fuses can usually be found at local vendor carriers such as automobile supply stores, hardware stores, etc. Refer to <b>Figure 5-8</b> for engine 25A fuse location.			

### NOTE

**If additional spare parts are being stored for future use, make certain that they are stored in proper containers that allow for protection against contamination, and kept in a clean area of moderate temperature reading. For information on storing the machine package for periods of non-use, consult Section 5.6.2, Long Term Storage.**



# 7.2A AIR N ARC 150 SYSTEMS ASSEMBLIES (8 GALLON, STAND ALONE, WELD ONLY, 12V AND 12/24V BATTERY BOOST)

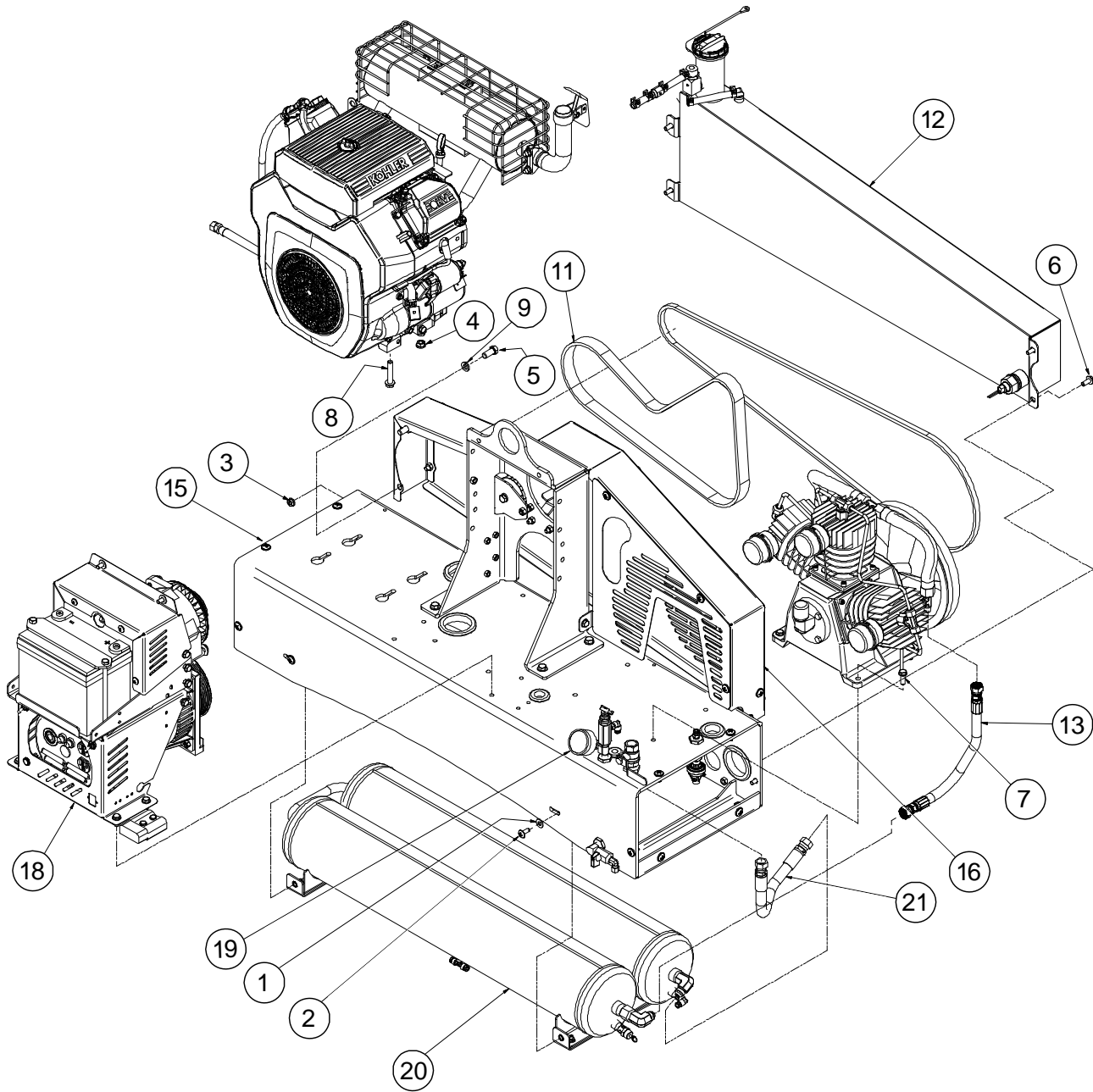

PA6130035ID\_r1

## 7.2A AIR N ARC 150 SYSTEMS ASSEMBLIES (8 GALLON, STAND ALONE, WELD ONLY, 12V AND 12/24V BATTERY BOOST)

ITEM	DESCRIPTION	PART NUMBER	QTY
1	WASHER, NYLON 5/16-18	262943	4
2	SCREW, TRUSS HD 5/16-18 x 3/4 SS	262945	4
3	NUT, HEX FLANGE 5/16-18	825305-283	1
4	NUT, HEX FLANGE 3/8-16	825306-347	4
5	CAPSCREW, HEX GR5 7/16-14 x 1	829107-100	2
6	SCREW, SER WASH 5/16-18 x 0.75	829705-075	4
7	SCREW, SER WASH 5/16-18 x 1	829705-100	4
8	SCREW, SER WASH 3/8-16 x 2	829706-200	4
9	WASHER, LOCK 7/16	838507-109	2
10	BELT, POWER TWIST 100 LINKS	DR23692	1
11	BELT, SERPENTINE, 6 RIB x 56.0", BLACK RUBBER	DR270926	1
12	FUEL TANK, ASSEMBLY 4.5 GAL	OA53433ID	1
13	HOSE, AIR CHARGE PRO 8 GALLON	PA42858-ASSY2	1
14	COMPRESSOR, ANA 150	PA6010076-01ID	1
15	ID, 8 GAL FRAME SKID	PA6030023ID	1
16	ID, BELT GUARD ASSEMBLY	PA6030024ID-001	1
17	ID, ENGINE & DRIVE PARTS 18HP	PA6100018ID-002	1
18	ID, ELECTRICAL SYSTEM, WELD ONLY	PA6120093ID	1
19	ID, CONTROL ASSEMBLY 8 GAL	PA6120091ID	1
20	ID, AIR TANK PRO 8 GALLON REMOTE	PA73089ID	1
21	HOSE, SERVICE AIR OUT	TU271164	1

**PLEASE NOTE: WHEN ORDERING PARTS, INDICATE MACHINE SERIAL NUMBER.**

# 7.2B AIR N ARC 150 SYSTEMS ASSEMBLIES (30 GALLON, STAND ALONE, WELD ONLY, 12V AND 12/24V BATTERY BOOST)

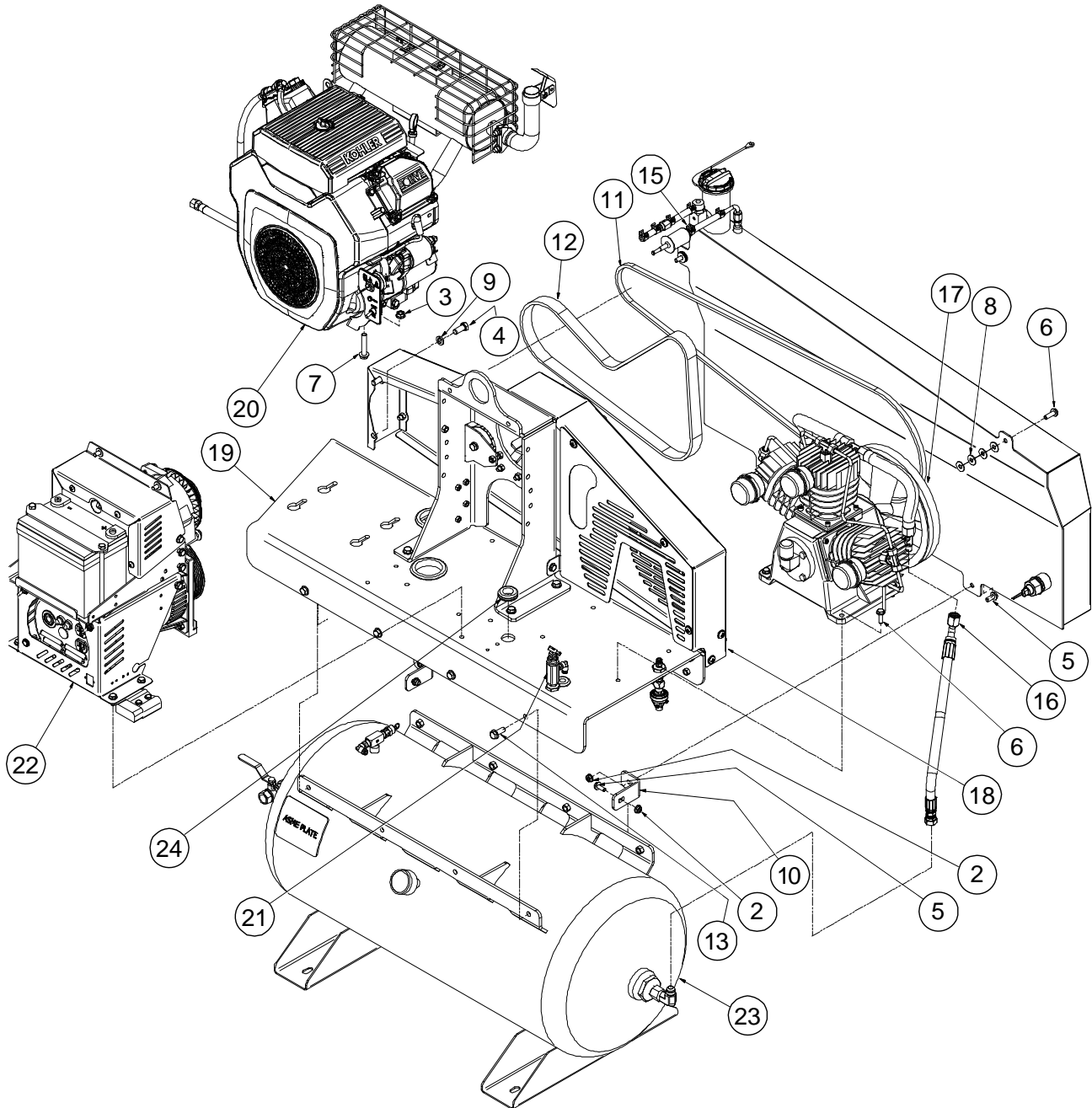

PA6130038ID\_r2

## 7.2B AIR N ARC 150 SYSTEMS ASSEMBLIES (30 GALLON, STAND ALONE, WELD ONLY, 12V AND 12/24V BATTERY BOOST)

ITEM	DESCRIPTION	PART NUMBER	QTY
1	SCHEMATIC, FLOW ANA 150 18HP	270928	1
2	NUT, HEX FLANGE 5/16-18	825305-283	4
3	NUT, HEX FLANGE 3/8-16	825306-347	4
4	CAPSCREW, HEX GR5 7/16-14 x 1	829107-100	2
5	SCREW, SER WASH 5/16-18 x 0.75	829705-075	4
6	SCREW, SER WASH 5/16-18 x 1	829705-100	6
7	SCREW, SER WASH 3/8-16 x 2	829706-200	4
8	WASHER, FLAT 5/16	838205-071	8
9	WASHER, LOCK 7/16	838507-109	2
10	MOUNT, FUEL TANK LOWER EXTENDED	A17492P	2
11	BELT, POWER TWIST 100 LINKS	DR23692	1
12	BELT, SERPENTINE, 6 RIB x 56.0", BLACK RUBBER	DR270926	1
13	SCREW, SER WASH 3/8-16 x 1	FA86645	8
14	WD, ANA 150 18HP, STAND ALONE	ID271188	1
15	ID, FUEL TANK ASSY 11.5 GAL	OA83450ID	1
16	HOSE, AIR CHARGE PRO 30 GALLON	PA32382	1
17	COMPRESSOR, ANA 150	PA6010076-01ID	1
18	ID, BELT GUARD ASSEMBLY	PA6030024ID-001	1
19	ID, FRAME ASSY, 30 GAL	PA6030026ID	1
20	ID, ENGINE AND DRIVE PARTS 18HP	PA6100022ID-002	1
21	ID, CONTROL ASS'Y 30 GAL & SKID, REMOTE	PA6120083ID	1
22	ID, ELECTRICAL SYSTEM, WELD ONLY	PA6120093ID	1
23	ID, AIR TANK, 30 GAL STAND ALONE	PA89907ID	1
24	GROMMET, BLACK RUBBER, .875ID	PR22730	1
25	HOSE, FUEL 1/4" SAE 30R9 x 40" LONG	TU269439	1

**PLEASE NOTE: WHEN ORDERING PARTS, INDICATE MACHINE SERIAL NUMBER.**

# 7.2C AIR N ARC 150 SYSTEMS ASSEMBLIES (STAND ALONE, SKID MOUNT, 12V AND 12/24V BATTERY BOOST)

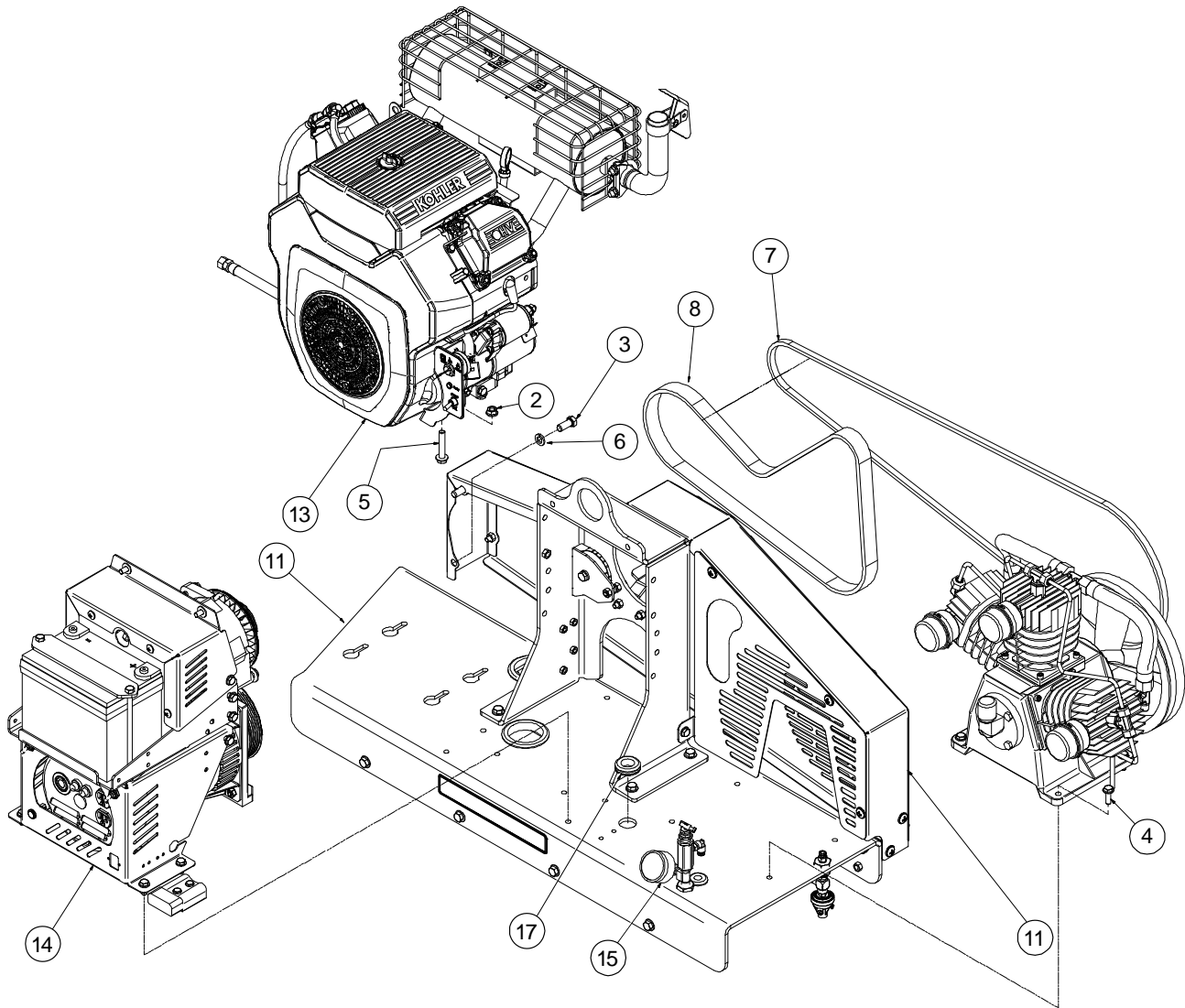

PA6130039ID\_r1



## 7.2C AIR N ARC 150 SYSTEMS ASSEMBLIES (STAND ALONE, SKID MOUNT, 12V AND 12/24V BATTERY BOOST)

ITEM	DESCRIPTION	PART NUMBER	QTY
1	SCHEMATIC, FLOW ANA 150 18HP	270928	1
2	NUT, HEX FLANGE 3/8-16	825306-347	4
3	CAPSCREW, HEX GR5 7/16-14 x 1	829107-100	2
4	SCREW, SER WASH 5/16-18 x 1	829705-100	4
5	SCREW, SER WASH 3/8-16 x 2	829706-200	4
6	WASHER, LOCK 7/16	838507-109	2
7	BELT, POWER TWIST 100 LINKS	DR23692	1
8	BELT, SERPENTINE, 6 RIB x 56.0", BLACK RUBBER	DR270926	1
9	WD, ANA 150 18HP, STAND ALONE	ID271188	1
10	COMPRESSOR, ANA 150	PA6010076-01ID	1
11	ID, BELT GUARD ASSEMBLY	PA6030024ID-001	1
12	ID, FRAME ASSY, SKID MOUNT	PA6030029ID	1
13	ID, ENGINE AND DRIVE PARTS 18HP	PA6100022ID-002	1
14	ID, ELECTRICAL SYSTEM, WELD ONLY	PA6120093ID	1
15	ID, CONTROL ASS'Y SKID STAND ALONE	PA6120095ID	1
16	ASS'Y, FUEL PUMP REMOTE FUEL	PA6140009ID	1
17	GROMMET, BLACK RUBBER, .875ID	PR22730	1

**PLEASE NOTE: WHEN ORDERING PARTS, INDICATE MACHINE SERIAL NUMBER.**

# 7.2D AIR N ARC 150 SYSTEMS ASSEMBLIES (8 GALLON, REMOTE PANEL, WELD ONLY, 12V AND 12/24V BATTERY BOOST)

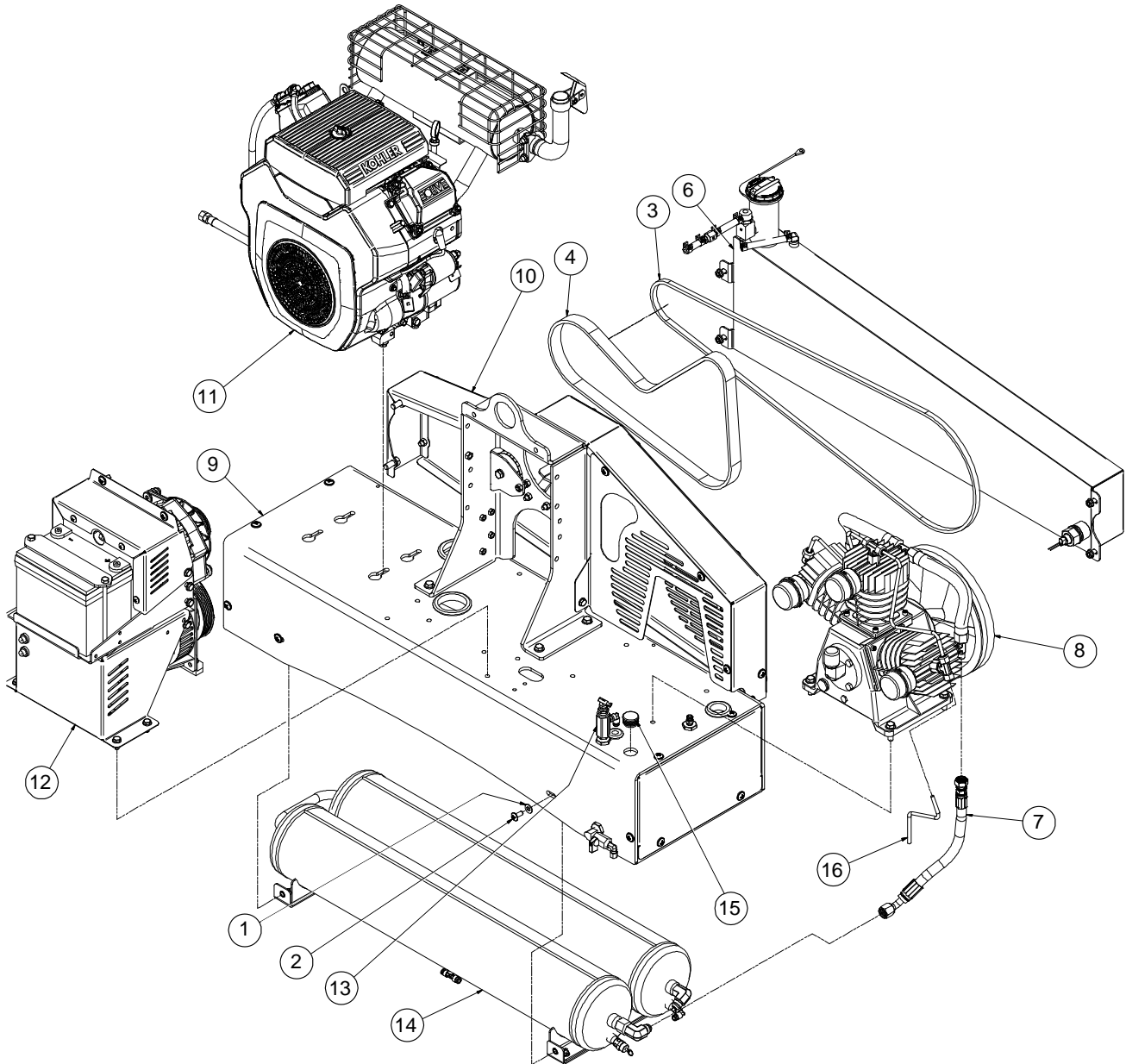

PA6130023-001ID\_r0

## 7.2D AIR N ARC 150 SYSTEMS ASSEMBLIES (8 GALLON, REMOTE PANEL, WELD ONLY, 12V AND 12/24V BATTERY BOOST)

ITEM	DESCRIPTION	PART NUMBER	QTY
1	WASHER, NYLON 5/16-18	262943	4
2	SCREW, TRUSS HD 5/16-18 x 3/4 SS	262945	4
3	BELT, POWER TWIST 102 LINKS	DR64616	1
4	BELT, SERPENTINE, 6 RIB x 56.0", BLACK RUBBER	DR270926	1
5	CABLE, WELD 20 FT WITH GROUND CLAMP	MA49835	1
6	FUEL TANK, ASSEMBLY 4.5 GAL	OA53433ID	1
7	HOSE, AIR CHARGE 8 GALON	PA42858	1
8	COMPRESSOR, ANA 150	PA6010076-001ID	1
9	ID, 8 GAL FRAME SKID	PA6030023ID	1
10	ID, BELT GUARD ASSEMBLY	PA6030024ID-001	1
11	ID, ENGINE & DRIVE PARTS 19HP	PA6100018ID-002	1
12	ID, ELECTRICAL SYSTEM REMOTE (ISO GROUND)	PA6120077-02ID	1
13	ID, CONTROL ASSEMBLY 8 GAL, REMOTE	PA6120078ID	1
14	ID, AIR TANK PRO 8 GALLON REMOTE	PA73089ID	1
15	PLUG, 1-1/4 DIA, RIBBED BLACK	PR96951	1
16	TUBING, COPPER 1/4" OD .030 WALL	TU67293	0.7 FT

**PLEASE NOTE: WHEN ORDERING PARTS, INDICATE MACHINE SERIAL NUMBER.**

# 7.2E AIR N ARC 150 SYSTEMS ASSEMBLIES (30 GALLON, REMOTE PANEL, WELD ONLY, 12V AND 12/24V BATTERY BOOST)

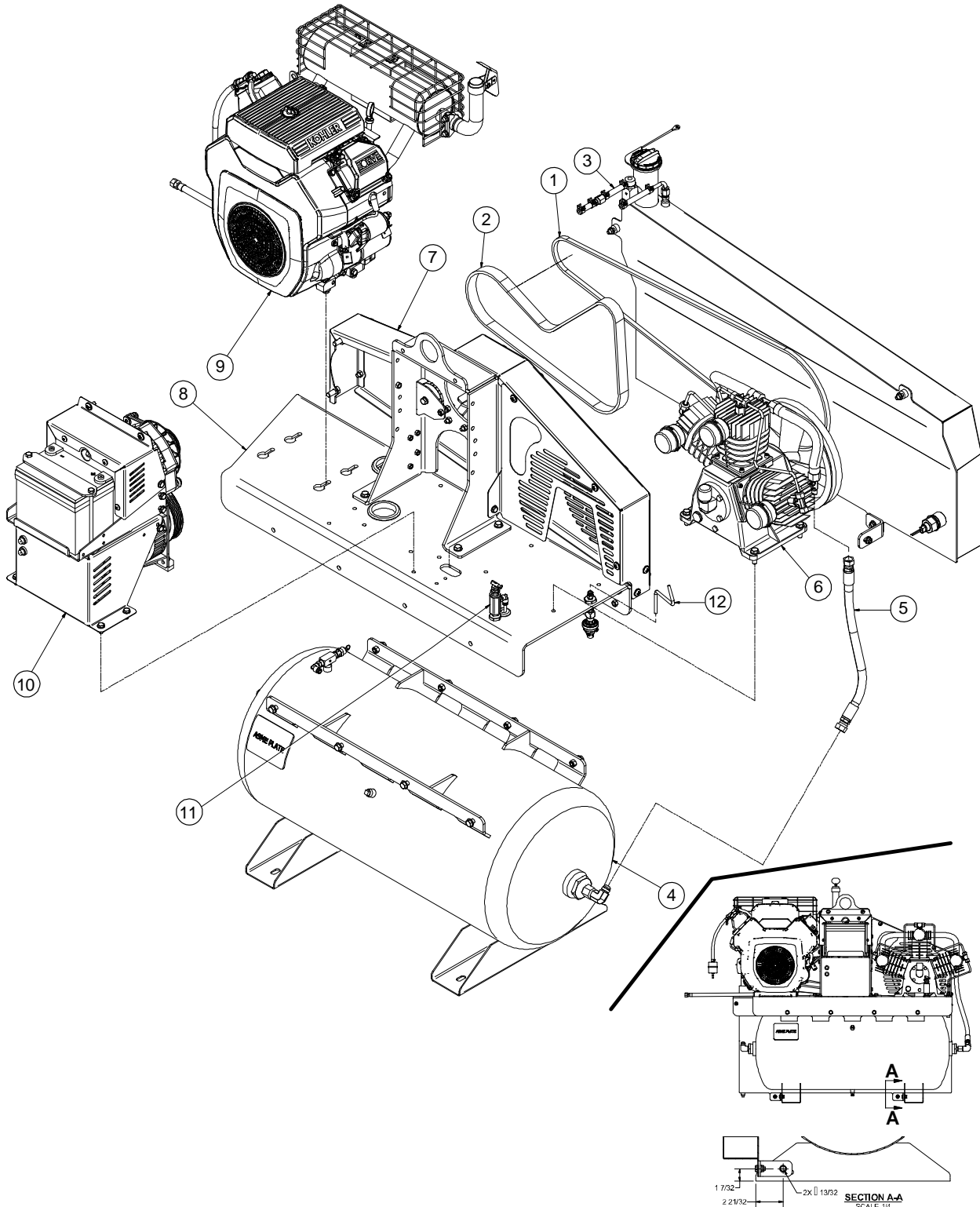

PA6130028-001ID\_r4

## 7.2E AIR N ARC 150 SYSTEMS ASSEMBLIES (30 GALLON, REMOTE PANEL, WELD ONLY, 12V AND 12/24V BATTERY BOOST)

ITEM	DESCRIPTION	PART NUMBER	QTY
1	BELT, POWER TWIST 102 LINKS	DR64616	1
2	BELT, SERPENTINE, 6 RIB x 56.0", BLACK RUBBER	DR270926	1
3	ID, FUEL TANK ASSY 11.5 GAL	OA83450ID	1
4	ID, AIR TANK, 30 GAL REMOTE	PA23932ID	1
5	HOSE AIR CHARGE PRO 30 GALLON	PA32382	1
6	COMPRESSOR, ANA 150	PA6010076-001ID	1
7	ID, BELT GUARD ASSEMBLY	PAA6030024ID-001	1
8	ID, FRAME ASSY, 30 GAL	PA6030026ID	1
9	ID, ENGINE & DRIVE PARTS 18 HP	PA6100018ID-002	1
10	ID, ELECTRICAL SYSTEM REMOTE (ISO GROUND)	PA6120077-02ID	1
11	ID, CONTROL ASSY 30 GAL.	PA6120201ID	1
12	TUBING, COPPER .030 WALL	TU67293	0.7 FT

**PLEASE NOTE: WHEN ORDERING PARTS, INDICATE MACHINE SERIAL NUMBER.**

# 7.2F AIR N ARC 150 SYSTEMS ASSEMBLIES (REMOTE PANEL, SKID MOUNT, WELD ONLY, 12V AND 12/24V BATTERY BOOST)

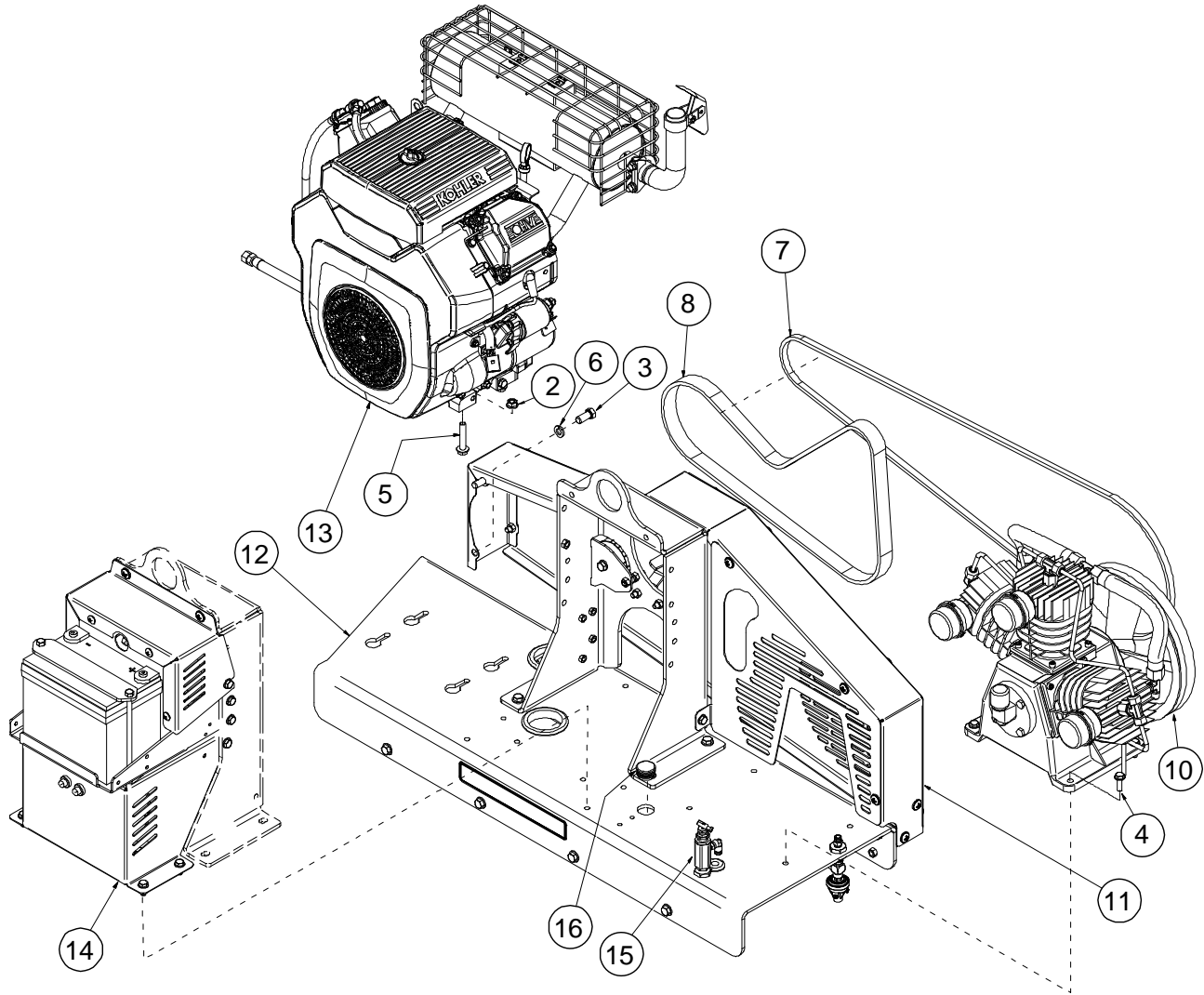

PA6130043ID\_r1

## 7.2F AIR N ARC 150 SYSTEMS ASSEMBLIES (REMOTE PANEL, SKID MOUNT, WELD ONLY, 12V AND 12/24V BATTERY BOOST)

ITEM	DESCRIPTION	PART NUMBER	QTY
1	SCHEMATIC, FLOW ANA 150 18HP	270928	1
2	NUT, HEX FLANGE 3/8-16	825306-347	4
3	CAPSCREW, HEX GR5 7/16-14 x 1	829107-100	2
4	SCREW, SER WASH 5/16-18 x 1	829705-100	4
5	SCREW, SER WASH 3/8-16 x 2	829706-200	4
6	WASHER, LOCK 7/16	838507-109	2
7	BELT, POWER TWIST 100 LINKS	DR23692	1
8	BELT, SERPENTINE, 6 RIB x 56.0", BLACK RUBBER	DR270926	1
9	WD, ANA 150 18HP	ID270921	1
10	COMPRESSOR, ANA 150	PA6010076-01ID	1
11	ID, BELT GUARD ASSEMBLY	PA6030024ID-001	1
12	ID, FRAME ASSY, SKID MOUNT	PA6030029ID	1
13	ID, ENGINE AND DRIVE PARTS 18HP	PA6100018ID-002	1
14	ID, ELECTRICAL SYSTEM, REMOTE	PA6120077ID	1
15	ID, CONTROL ASS'Y 30 GAL AND SKID, REMOTE	PA6120083ID	1
16	PLUG, 1-1/4 DIA, RIBBED BLACK	PR96951	1

**PLEASE NOTE: WHEN ORDERING PARTS, INDICATE MACHINE SERIAL NUMBER.**

# 7.3 COMPRESSOR AND PARTS

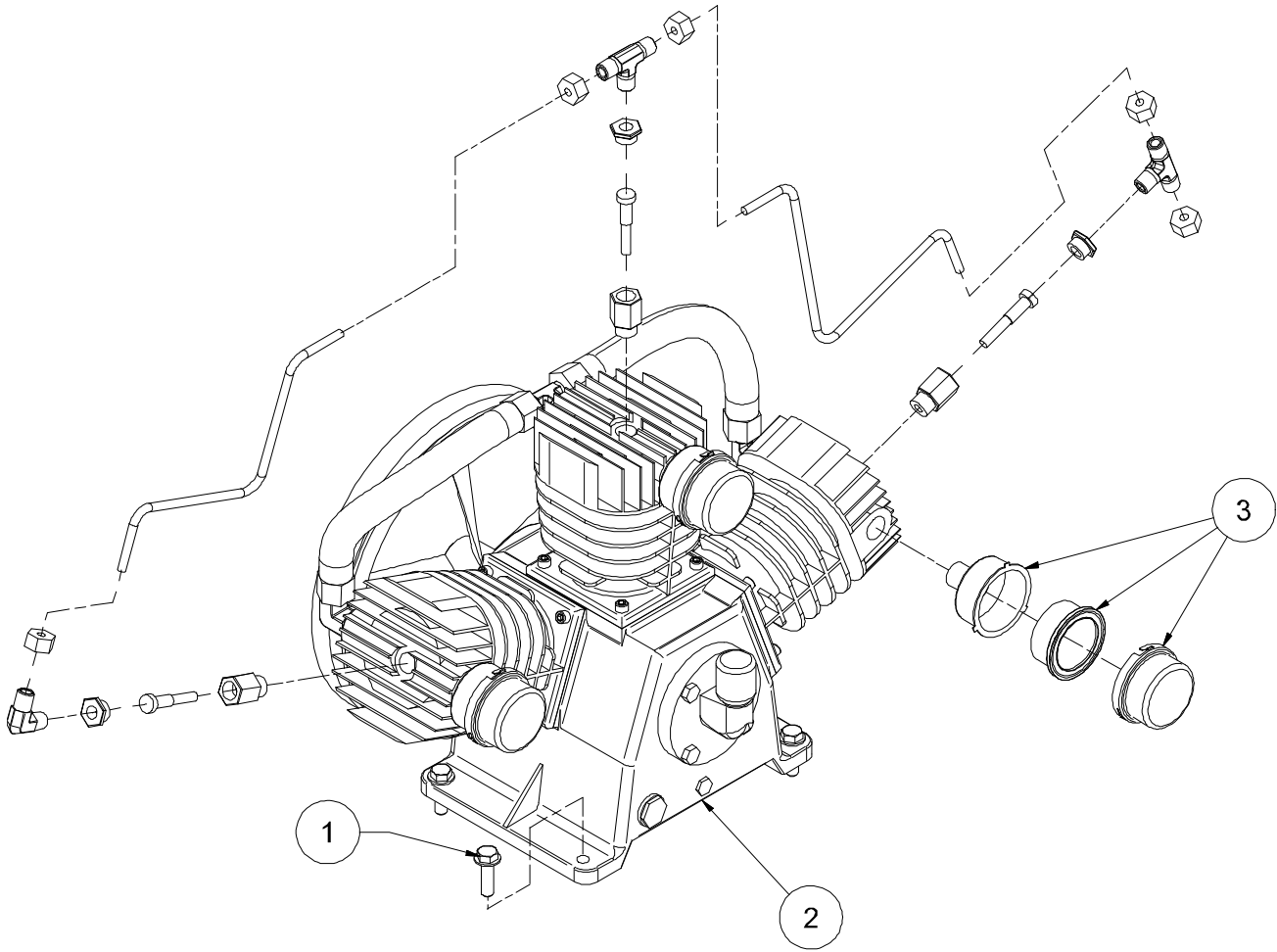

PA6010076-001ID\_r3



## 7.3 COMPRESSOR AND PARTS

ITEM	DESCRIPTION	PART NUMBER	QTY
1	SCREW, SER WASH 3/8-16 x 1.25	829706-125	4
2	COMPRESSOR, AIR , 3 CYL	CM271646	1
3	FILTER, AIR ASSEMBLY <sup>I</sup>	CM271646-01	3
4	OIL, HYD ISO68	SE99966	1qt

<sup>I</sup> Consult **Table 7A: Recommended Spare Parts List** for compressor air filter maintenance parts.

**PLEASE NOTE: WHEN ORDERING PARTS, INDICATE MACHINE SERIAL NUMBER.**

# 7.4A FRAME ASSEMBLY (ALL 8 GALLON MODELS)

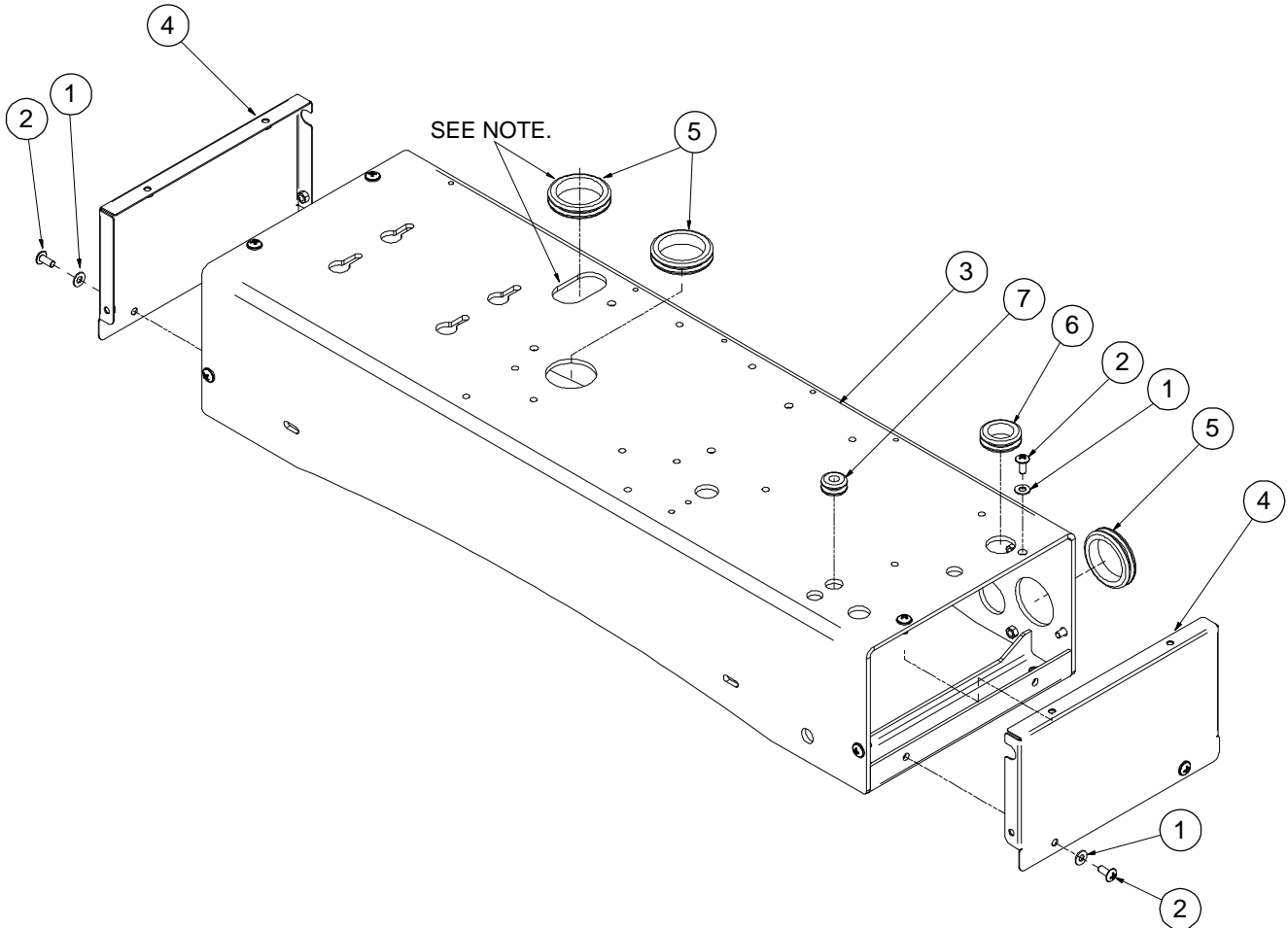

PA6030023ID\_r2

## 7.4A FRAME ASSEMBLY (ALL 8 GALLON MODELS)

ITEM	DESCRIPTION	PART NUMBER	QTY
1	WASHER, NYLON 5/16-18	262943	12
2	SCREW, TRUSS HD 5/16-18 x 3/4 SS	262945	12
3	PLATFORM, 8 GALLON	A1270877	1
4	COVER, PLATFORM END	A17510P	2
5	GROMMET, BLACK RUBBER, 2.25ID	PR74492	3
6	GROMMET, BLACK RUBBER, 1.25ID	PR75487	1
7	GROMMET, BLACK RUBBER, .50ID	PR52720	1

**Note** <sup>1</sup>: Drawing may not depict actual part shape.

**PLEASE NOTE: WHEN ORDERING PARTS, INDICATE MACHINE SERIAL NUMBER.**

# 7.4B FRAME ASSEMBLY (ALL 30 GALLON MODELS)

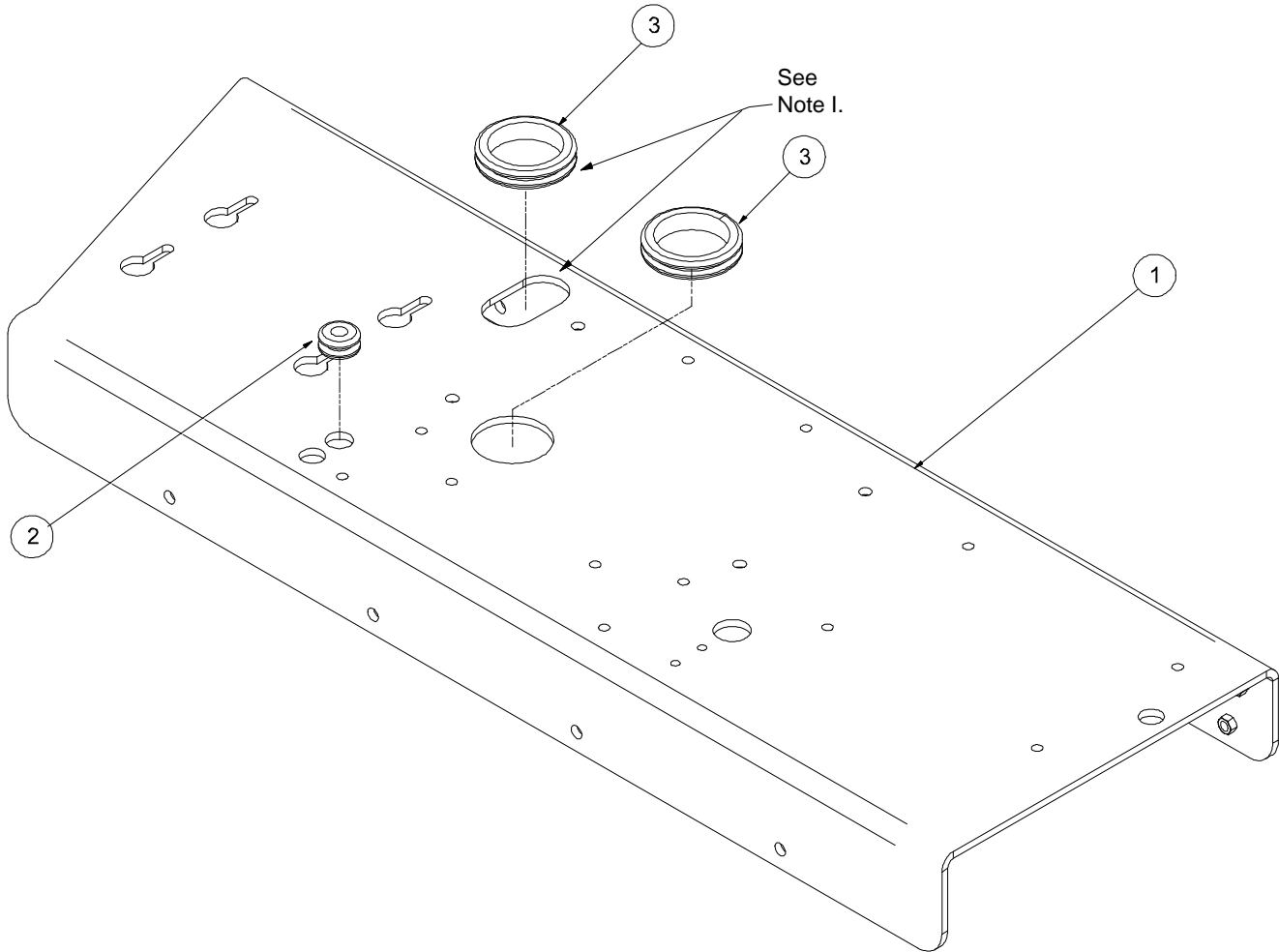

PA6030026ID\_r0

## 7.4B FRAME ASSEMBLY (ALL 30 GALLON MODELS)

ITEM	DESCRIPTION	PART NUMBER	QTY
1	PLATFORM, 30 GALLON AND SKID	A1270964	1
2	GROMMET, BLACK RUBBER, 2.25ID	PR52720	1
3	GROMMET, BLACK RUBBER, 2.25ID	PR74492	2

**Note** <sup>1</sup>: Drawing may not depict actual part shape.

**PLEASE NOTE: WHEN ORDERING PARTS, INDICATE MACHINE SERIAL NUMBER.**

# 7.4C FRAME ASSEMBLY (ALL SKID MOUNT MODELS)

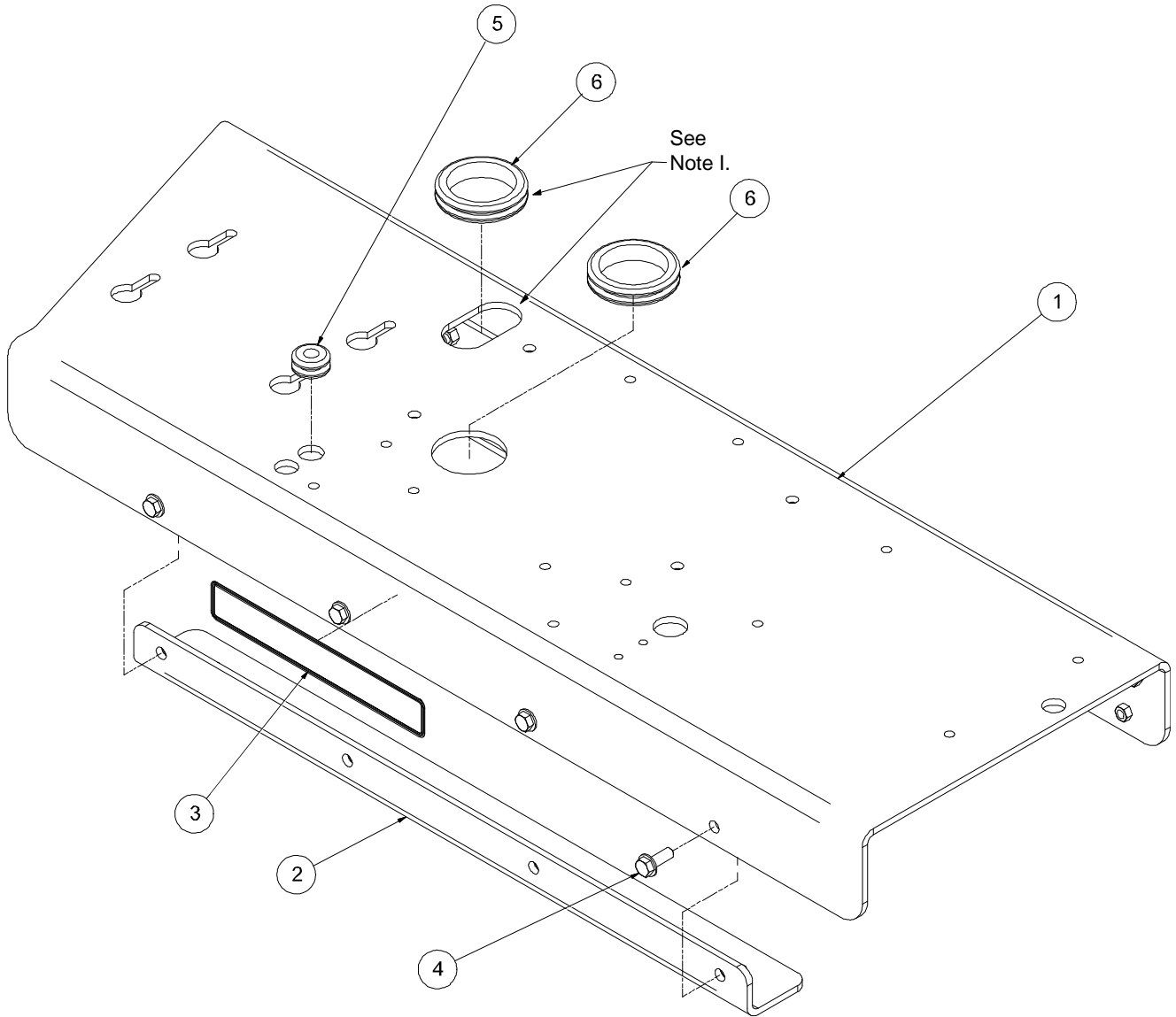

PA6030029ID\_r1

## 7.4C FRAME ASSEMBLY (ALL SKID MOUNT MODELS)

ITEM	DESCRIPTION	PART NUMBER	QTY
1	PLATFORM, 30 GALLON AND SKID	A1270964	1
2	MOUNT, SKID PRO / CONTRACTOR	A16986P	2
3	DECAL, INFO VANAIR	DL271081	1
4	SCREW, SER WASH 3/8-16 x 1	FA86645	8
5	GROMMET, BLACK RUBBER, 2.25ID	PR52720	1
6	GROMMET, BLACK RUBBER, 2.25ID	PR74492	2
<b>Note</b> <sup>T</sup> : Drawing may not depict actual part shape.			

**PLEASE NOTE: WHEN ORDERING PARTS, INDICATE MACHINE SERIAL NUMBER.**

# 7.5A CONTROL ASSEMBLY (SKID MOUNT, 8 GALLON, 30 GALLON MODELS)

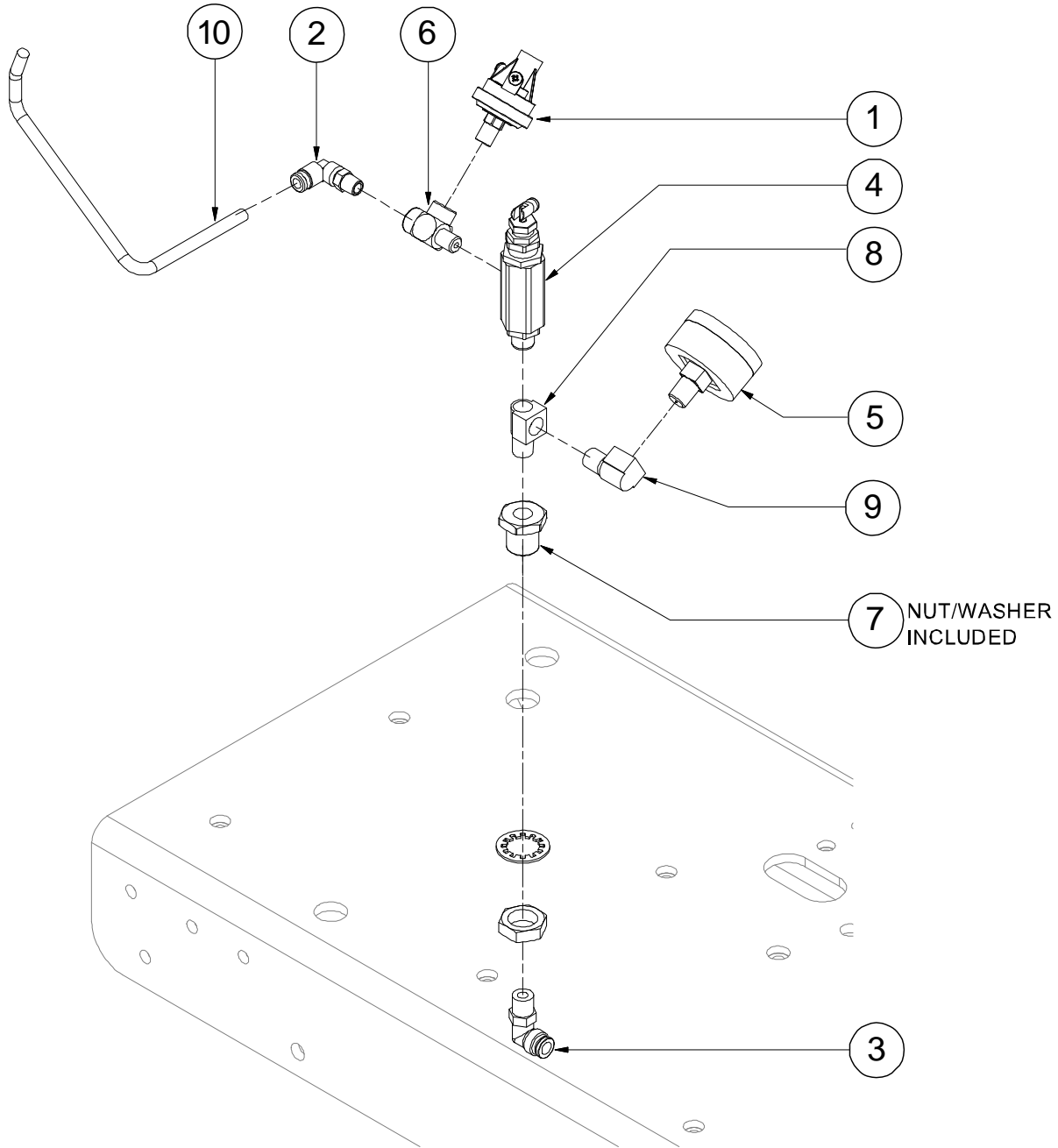

PA6120210ID\_r0



## 7.5A CONTROL ASSEMBLY (SKID MOUNT, 8 GALLON, 30 GALLON MODELS)

ITEM	DESCRIPTION	PART NUMBER	QTY
1	SWITCH, PRESSURE N.C. 10 PSI	260818	1
2	ELBOW, 1/4T x 1/8P PUSH-ON	261309	1
3	ELBOW, 5/16T x 1/4P PUSH-ON	267187	1
4	VALVE, PILOT, 95-125 PSI, 1/4	CO25331	1
5	GAUGE, AIR CRY 0-200 PSI	CO47028	1
6	TEE, MALE STREET 1/8 x 1/8 x 1/8	FI31152	1
7	PIPE BRASS, BULKHEAD 1/4 NPT	FI45068	1
8	TEE, STREET 1/4 NPT BRASS	FI53603	1
9	PIPE BRASS, 1/4 NPT, 90 DEG. STREET ELBOW	FI65532	1
10	TUBE, UNLOADER 1/4 COPPER	TU274736	0.804 ft

**PLEASE NOTE: WHEN ORDERING PARTS, INDICATE MACHINE SERIAL NUMBER.**

# 7.5B CONTROL ASSEMBLY (8 GALLON, STAND-ALONE MODELS)

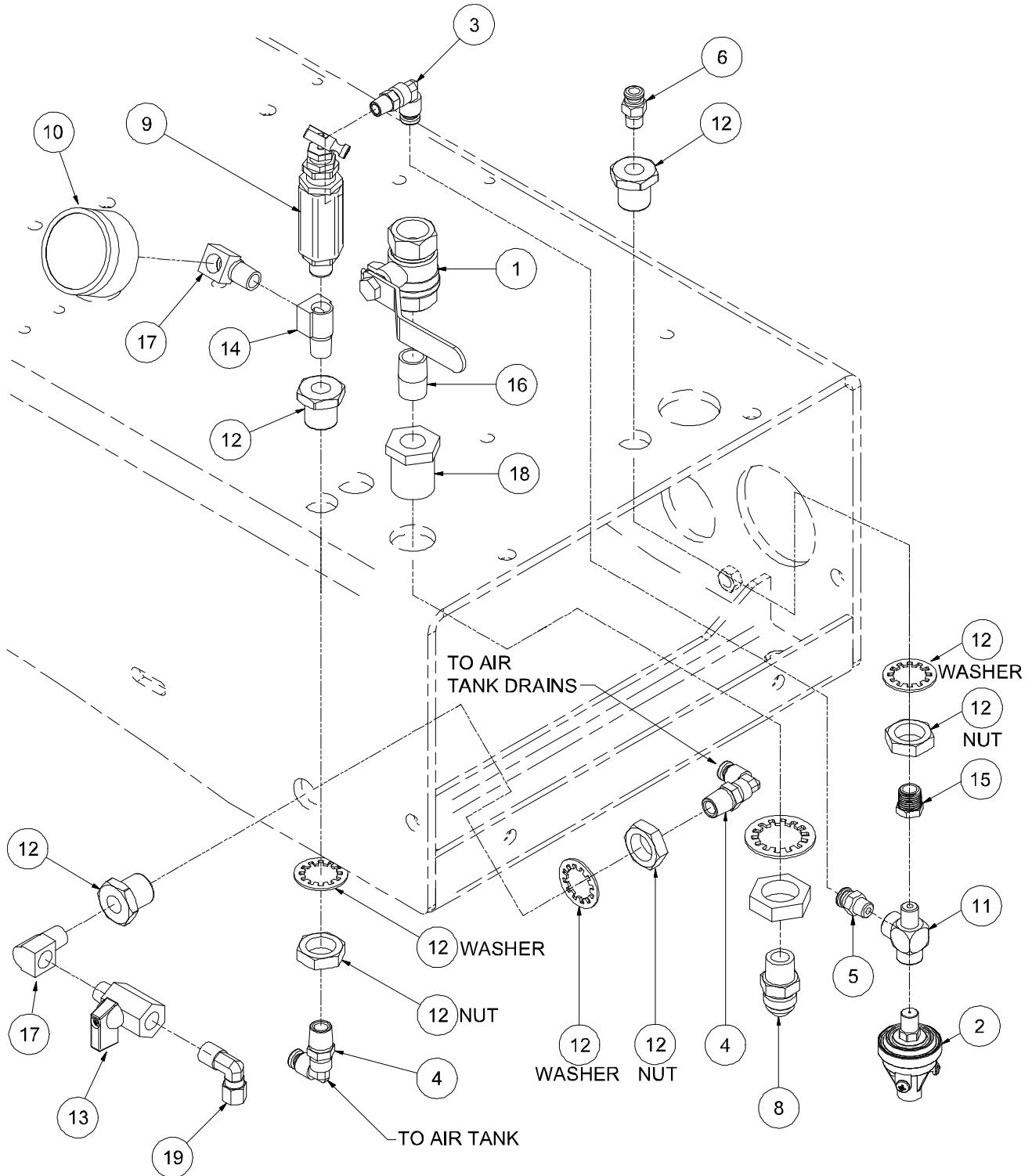

PA6120091ID\_r2

## 7.5B CONTROL ASSEMBLY (8 GALLON, STAND-ALONE MODELS)

ITEM	DESCRIPTION	PART NUMBER	QTY
1	VALVE, SERVICE 1/2	260448	1
2	SWITCH, PRESSURE N.C. 10 PSI	260818	1
3	ELBOW, 1/4T x 1/8P PUSH-ON	261309	1
4	ELBOW, 90 DEG. PUSH ON 1/4T x 1/4P	261310	2
5	CONNECTOR, 1/8P x 1/4T PUSH ON	261316	1
6	CONNECTOR, 1/4P x 1/4T PUSH ON	261317	1
7	TUBING, 1/4 DIA, NYLON, 230 PSI x 13 FT.	264480	1
8	CONNECTOR, 37FL/MPT #08 x 3/8	860108-038	1
9	VALVE, PILOT, 95-125 PSI, 1/4	CO25331	1
10	GAUGE, AIR DRY 0-200 PSI	CO47028	1
11	TEE, MALE STREET 1/8 x 1/8 x 1/8	FI31152	1
12	PIPE BRASS, BULKHEAD 1/4 NPT	FI45068	3
13	VALVE, BALL MINI, 1/4 NPT M/F	FI48014	1
14	TEE, STREET 1/4 NPT BRASS	FI53603	1
15	PIPE, BUSHING, REDUCING, 1/4 M	FI54915	1
16	NIPPLE, PIPE BRASS, 3/8 NPT x CLOSE	FI59676	1
17	PIPE BRASS, 1/4 NPT, 90 DEG. STREET ELBOW	FI65532	2
18	PIPE BRASS, BULKHEAD 3/8 NPT	FI67811	1
19	ELBOW, COMP 1/4MNPT x 1/4 TUBE	FI79286	1

**PLEASE NOTE: WHEN ORDERING PARTS, INDICATE MACHINE SERIAL NUMBER.**

# 7.5C CONTROL ASSEMBLY (30 GALLON, STAND-ALONE MODELS)

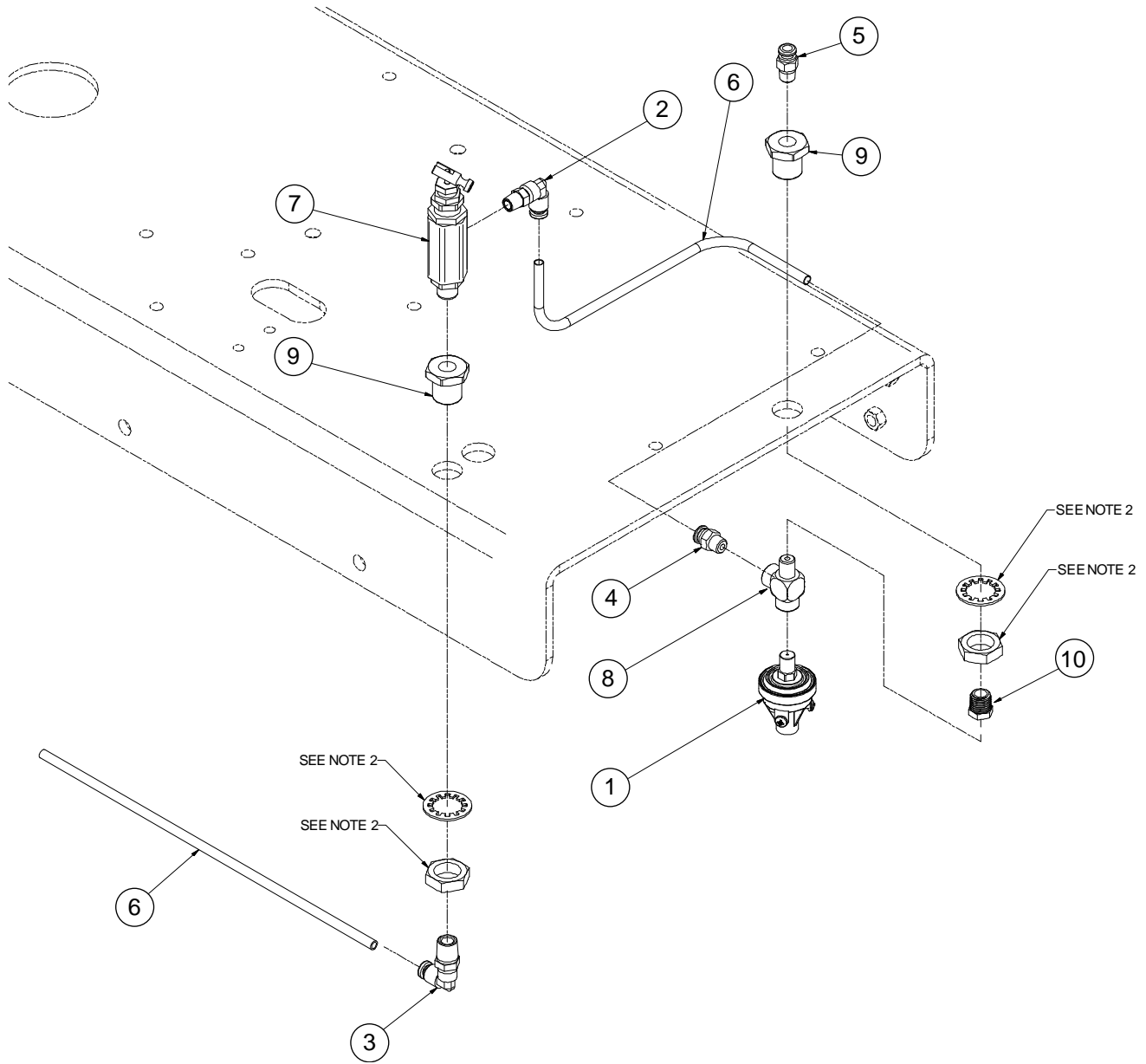

PA6120201ID\_r0

## 7.5C CONTROL ASSEMBLY (30 GALLON, STAND-ALONE MODELS)

ITEM	DESCRIPTION	PART NUMBER	QTY
1	SWITCH, PRESSURE N.C. 10 PSI	260818	1
2	ELBOW, 1/4T x 1/8P PUSH-ON	261309	1
3	ELBOW, 90 DEG. PUSH-ON 1/4T x 1/4P	261310	1
4	CONNECTOR, 1/8P x 1/4T PUSH-ON	261316	1
5	CONNECTOR, 1/4P x 1/4T PUSH-ON	261317	1
6	HOSE, AIR BRAKE 1/4	264480	4.669 ft
7	VALVE, PILOT, 95-125 PSI, 1/4	CO25331	1
8	TEE, MALE STREET 1/8 x 1/8 x 1/8	FI31152	1
9	PIPE BRASS, BULKHEAD 1/4 NPT	FI45068	2
10	PIPE, BUSHING, REDUCING, 1/4 M	FI54915	1

<sup>II</sup> Nut and washer included with bulkhead (item #9).

**PLEASE NOTE: WHEN ORDERING PARTS, INDICATE MACHINE SERIAL NUMBER.**

# 7.5D CONTROL ASSEMBLY (REMOTE PANEL SKID MOUNT MODELS)

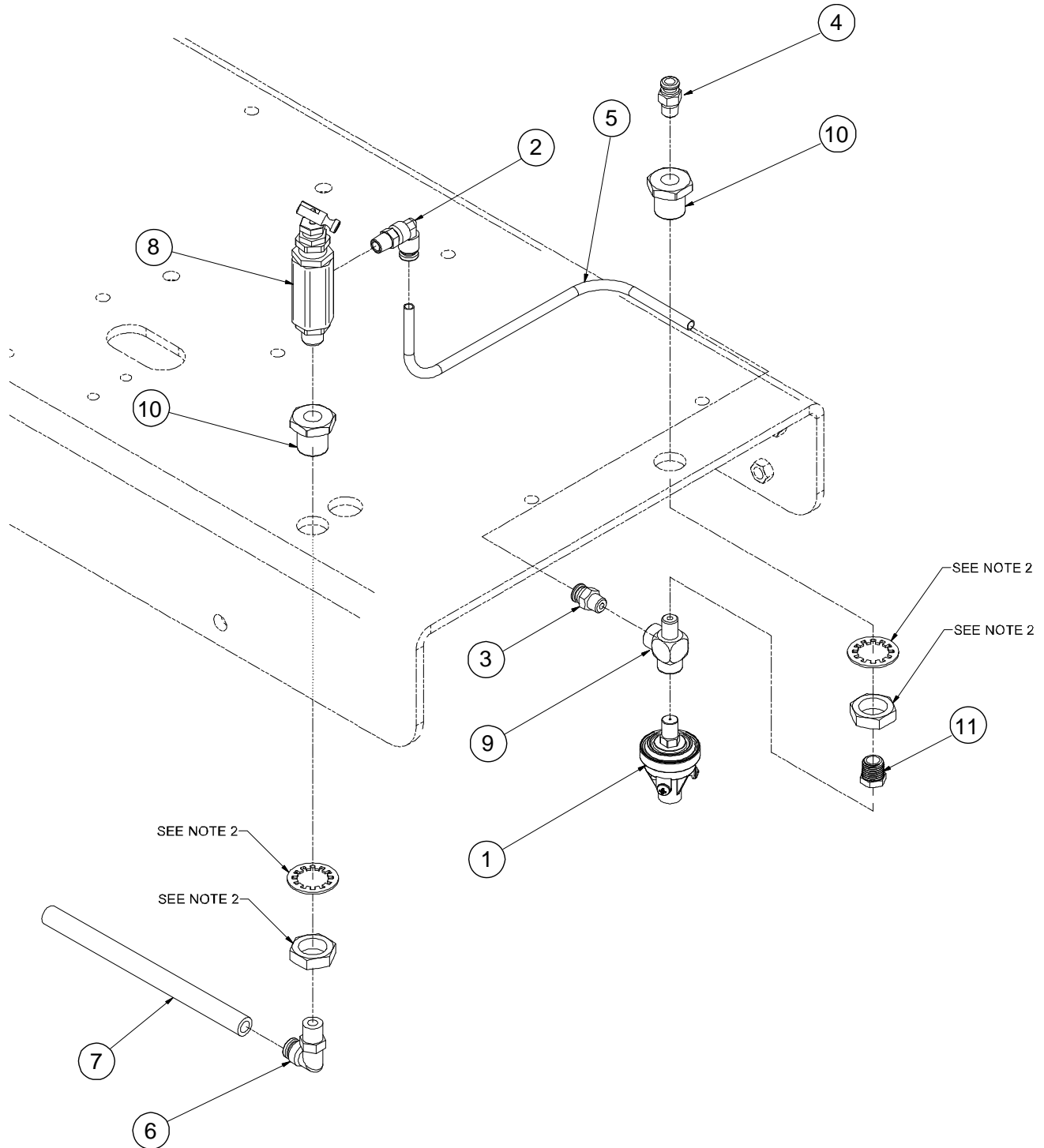

PA6120083ID\_r4

## 7.5D CONTROL ASSEMBLY (REMOTE PANEL SKID MOUNT MODELS)

ITEM	DESCRIPTION	PART NUMBER	QTY
1	SWITCH, PRESSURE N.C. 10 PSI	260818	1
2	ELBOW, 1/4T x 1/8P PUSH-ON	261309	1
3	CONNECTOR, 1/8P x 1/4T PUSH-ON	261316	1
4	CONNECTOR, 1/4P x 1/4T PUSH-ON	261317	1
5	TUBING, 1/4DIA, NYLON, 230 PSI x 1 FT.	264480	1.00 FT
6	ELBOW, 5/16T x 1/4 P PUSH-ON	267187	1
7	TUBING, PLASTIC 5/16 RED	267189	1.00 FT
8	VALVE, PILOT, 95-125 PSI, 1/4	CO25331	1
9	TEE, MALE STREET 1/8 x 1/8 x 1/8	FI31152	1
10	PIPE BRASS, BULKHEAD 1/4 NPT	FI45068	2
11	PIPE, BUSHING, REDUCING, 1/4M	FI54915	1

*II* Nut and washer included with bulkhead.

**PLEASE NOTE: WHEN ORDERING PARTS, INDICATE MACHINE SERIAL NUMBER.**

# 7.5E CONTROL ASSEMBLY (ALL STAND ALONE, SKID MOUNT MODELS)

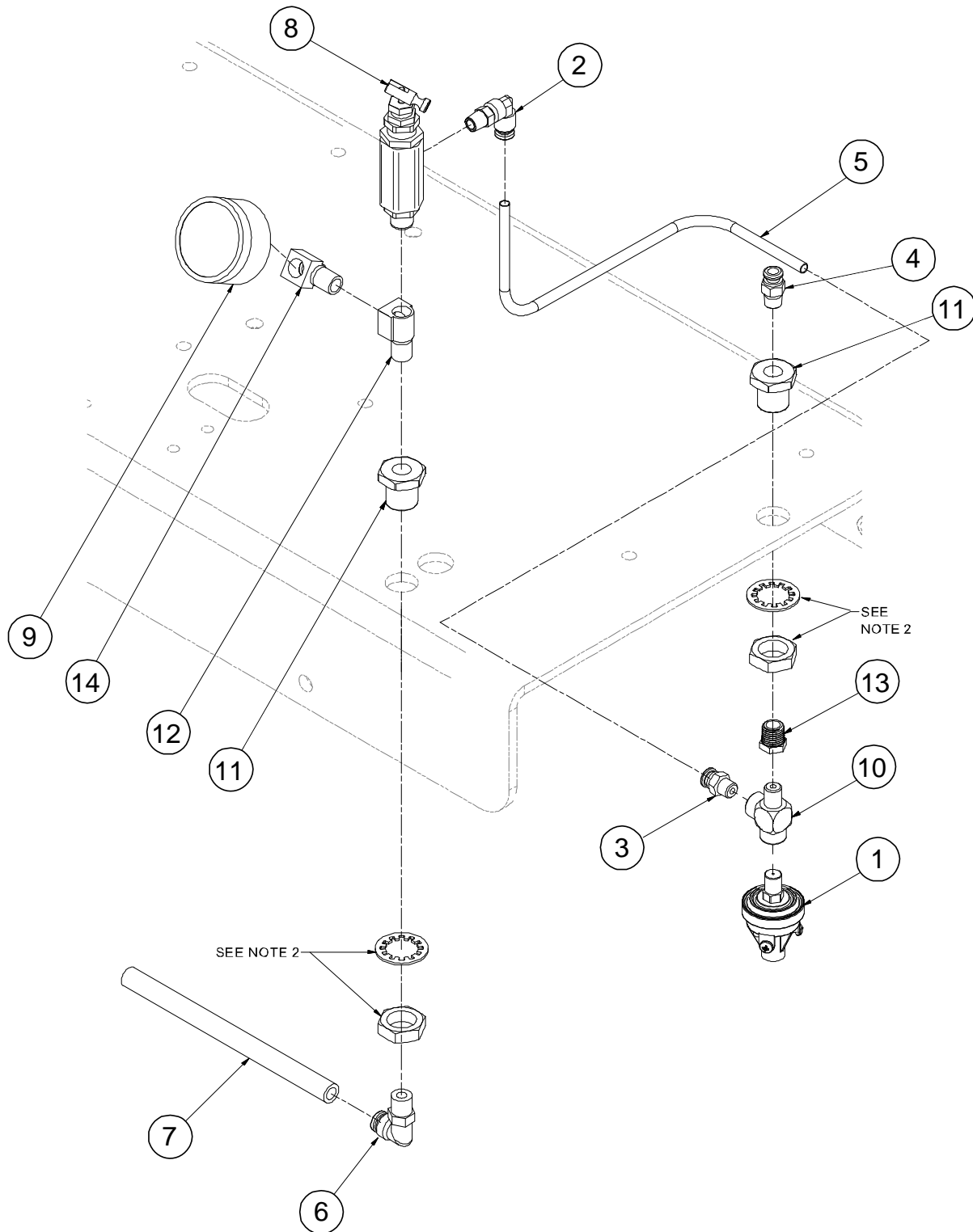

PA6120095ID\_r3



## 7.5E CONTROL ASSEMBLY (ALL STAND ALONE, SKID MOUNT MODELS)

ITEM	DESCRIPTION	PART NUMBER	QTY
1	SWITCH, PRESSURE N.C. 10 PSI	260818	1
2	ELBOW, 1/4T x 1/8 x 1/4T PUSH-ON	261309	1
3	CONNECTOR, 1/4P x 1/4T PUSH-ON	261316	1
4	CONNECTOR, 1/4P x 1/4T PUSH-ON	261317	1
5	HOSE, AIR BRAKE 1/4	264480	1.11 FT
6	ELBOW, 5/16T x 1/4P PUSH-ON	267187	1
7	TUBING, PLASTIC 5/16 RED	267189	1.000 FT
8	VALVE, PILOT, 95-125 PSI, 1/4	CO25331	1
9	GAUGE, AIR DRY 0-200 PSI	CO47028	1
10	TEE, MALE STREET 1/8 x 1/8 x 1/8	FI31152	1
11	PIPE BRASS, BULKHEAD 1/4 NPT	FI45068	2
12	TEE, STREET 1/4 NPT BRASS	FI53603	1
13	PIPE, BUSHING, REDUCING, 1/4M	FI54915	1
14	PIPE BRASS, 1/4 NPT, 90 DEG. STREET ELBOW	FI65532	1
<i>II</i> Nut and washer included with bulkhead.			

**PLEASE NOTE: WHEN ORDERING PARTS, INDICATE MACHINE SERIAL NUMBER.**

# 7.5F CONTROL ASSEMBLY (ALL 8 GALLON, REMOTE PANEL MODELS)

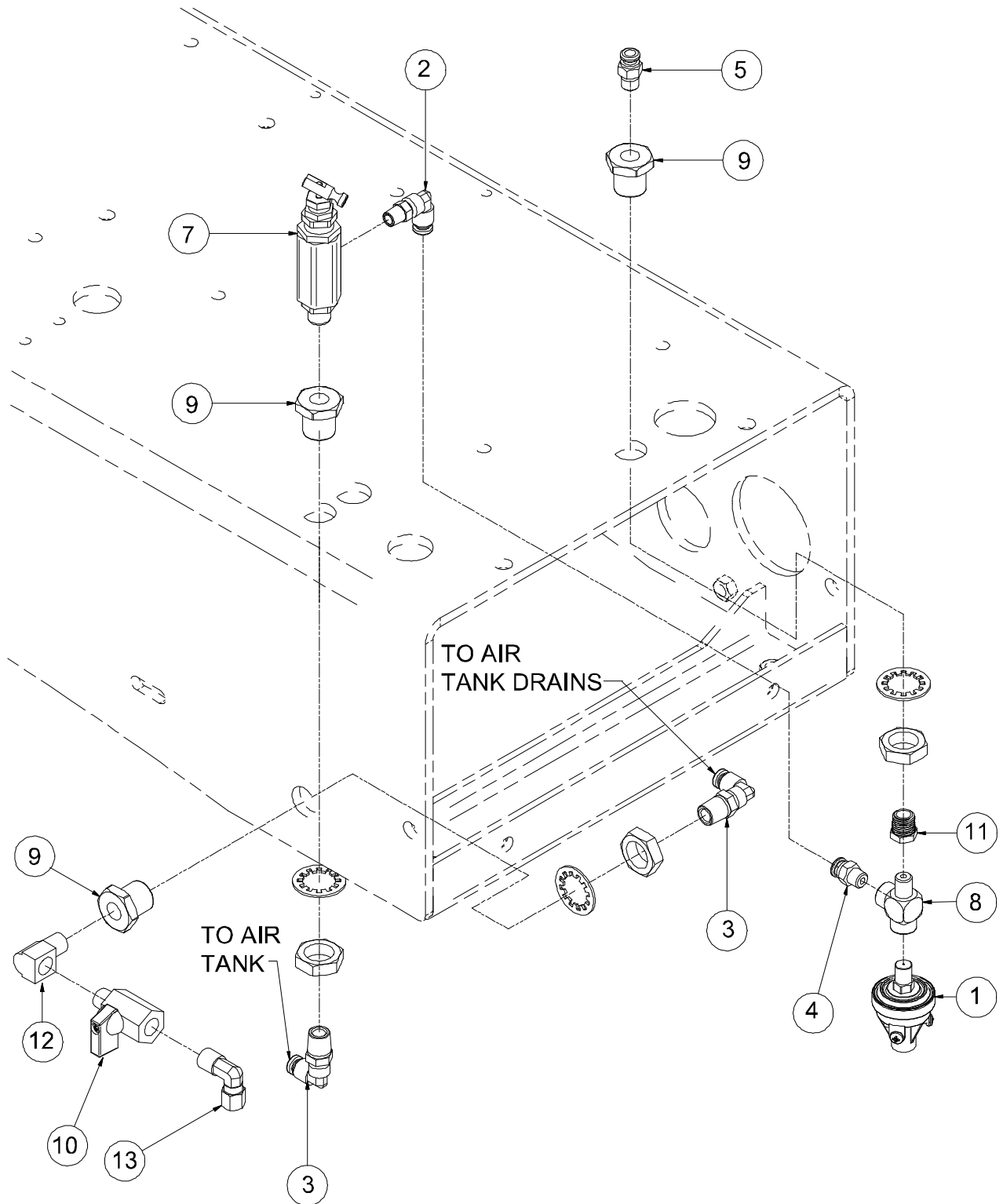

PA6120078ID\_r2

## 7.5F CONTROL ASSEMBLY (ALL 8 GALLON, REMOTE PANEL MODELS)

ITEM	DESCRIPTION	PART NUMBER	QTY
1	SWITCH, PRESSURE N.C. 10 PSI	260818	1
2	ELBOW, 1/4T x 1/8P PUSH-ON	261309	1
3	ELBOW, 90 DEG. PUSH ON 1/4T x 1/4P	261310	2
4	CONNECTOR, 1/8P x 1/4T PUSH ON	261316	1
5	CONNECTOR, 1/4P x 1/4T PUSH ON	261317	1
6	TUBING, 1/4 DIA., NYLON, 230 PSI x 13 FT.	264480	1
7	VALVE, PILOT, 95-125 PSI, 1/4	CO25331	1
8	TEE, MALE STREET 1/8 x 1/8 x 1/8	FI31152	1
9	PIPE BRASS, BULKHEAD 1/4 NPT	FI45068	3
10	VALVE, BALL MINI, 1/4 NPT M/F	FI48014	1
11	PIPE, BUSHING, REDUCING, 1/4 M	FI54915	1
12	PIPE BRASS, 1/4 NPT, 90 DEG. STREET ELBOW	FI65532	1
13	ELBOW, COMP 1/4 MNPT x 1/4 TUBE	FI79286	1

**PLEASE NOTE: WHEN ORDERING PARTS, INDICATE MACHINE SERIAL NUMBER.**

# 7.6A ENGINE AND DRIVE PARTS (ALL STAND ALONE MODELS)

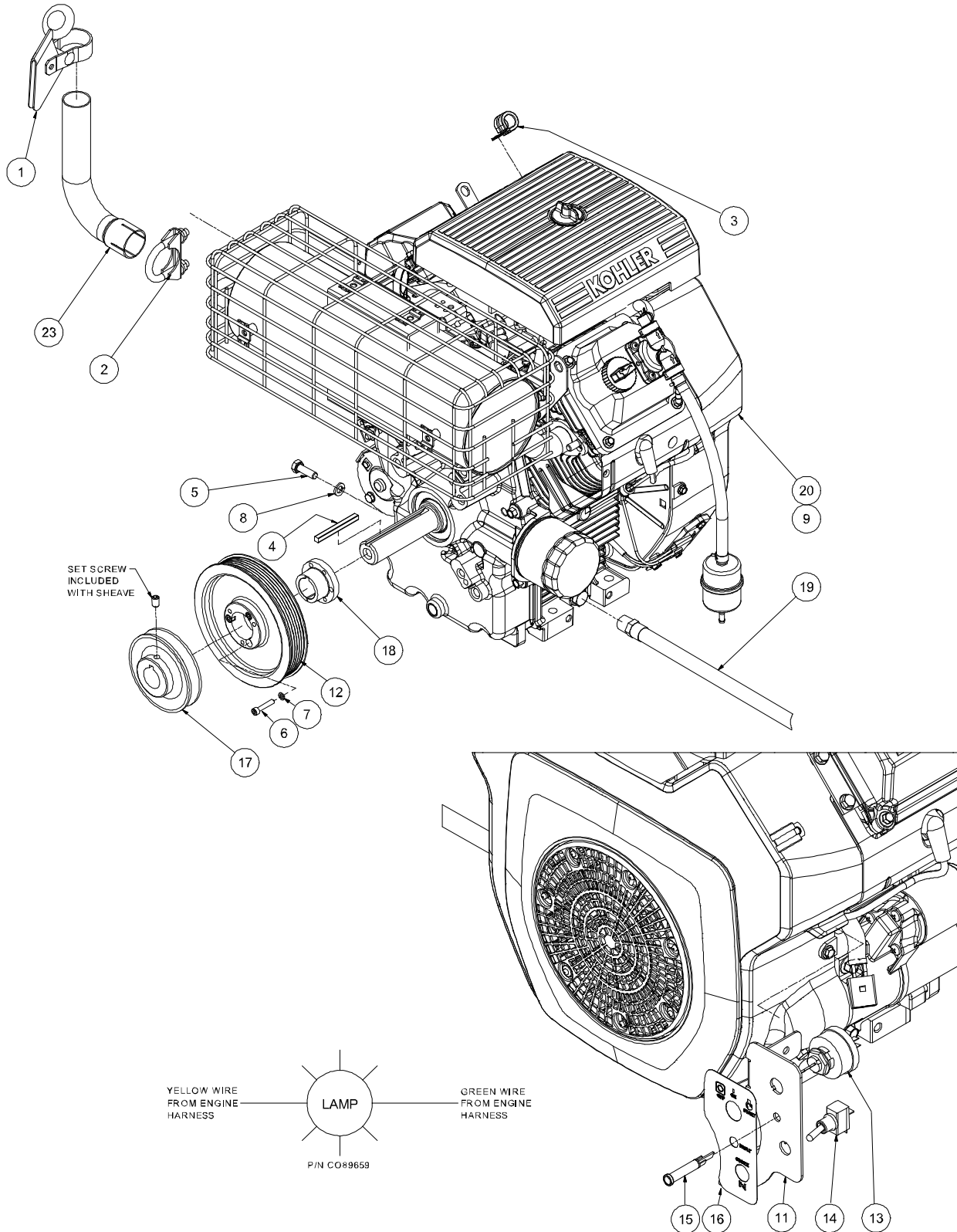

PA6100022ID-002\_r0

## 7.6A ENGINE AND DRIVE PARTS (ALL STAND ALONE MODELS)

ITEM	DESCRIPTION	PART NUMBER	QTY
1	CAP, RAIN 1-1/4" EXHAUST	262706	1
2	CLAMP, EXHAUST 1-1/4 REV.0	262906	1
3	CLAMP, LOOM #010 5/8"	268503	1
4	KEY, SQUARE 1/4 x 1/4 x 2.5	821104-250	1
5	CAPSCREW, HEX M8-1.25 x 25mm	828008-025	1
6	CAPSCREW, S.H. #10-25UNC x 1	828302-100	3
7	WASHER, LOCK #10	838502-047	3
8	WASHER, LOCK METRIC M8	88808-200	1
9	OIL, MOTOR 10W-30	844300-001	2 QTS.
10	TERMINAL, PUSH-ON 22-18GA .180	849522-180	2
11	PANEL, ENGINE CONTROL 18HP STANDALONE	A1271038	1
12	SHEAVE, SERPENTINE, 6 GROOVE	A12924Z	1
13	SWITCH, IGNITION EFI ENGINES	CO269713	1
14	SWITCH, TOGGLE SPST ON/OFF MYRY	CO64073	1
15	LAMP, INDICATOR, LED, RED	CO89659	1
16	DECAL, ENGINE CNTRL PANEL 18HP STANDALONE	DL271039	1
17	SHEAVE, SINGLE GROOVE 1"	DR271968	1
18	BUSHING, JA, QD, 1 DIA., 3 BO	DR57469Z	1
19	HOSE, DRAIN 3/8 x 12" LG 3/8 NPT	EN22698	1
20	ENGINE, 19HP V-TWIN	EN271037	1
21	HARNESS, STAND ALONE DC POWER	EP271067	1
22	HARNESS, CHOKE SWITCH JUMPER	EP2711887	1
23	TUBE, EXHAUST 1.25 DIA	TU270889	1

**PLEASE NOTE: WHEN ORDERING PARTS, INDICATE MACHINE SERIAL NUMBER.**

# 7.6B ENGINE AND DRIVE PARTS (ALL REMOTE PANEL MODELS)

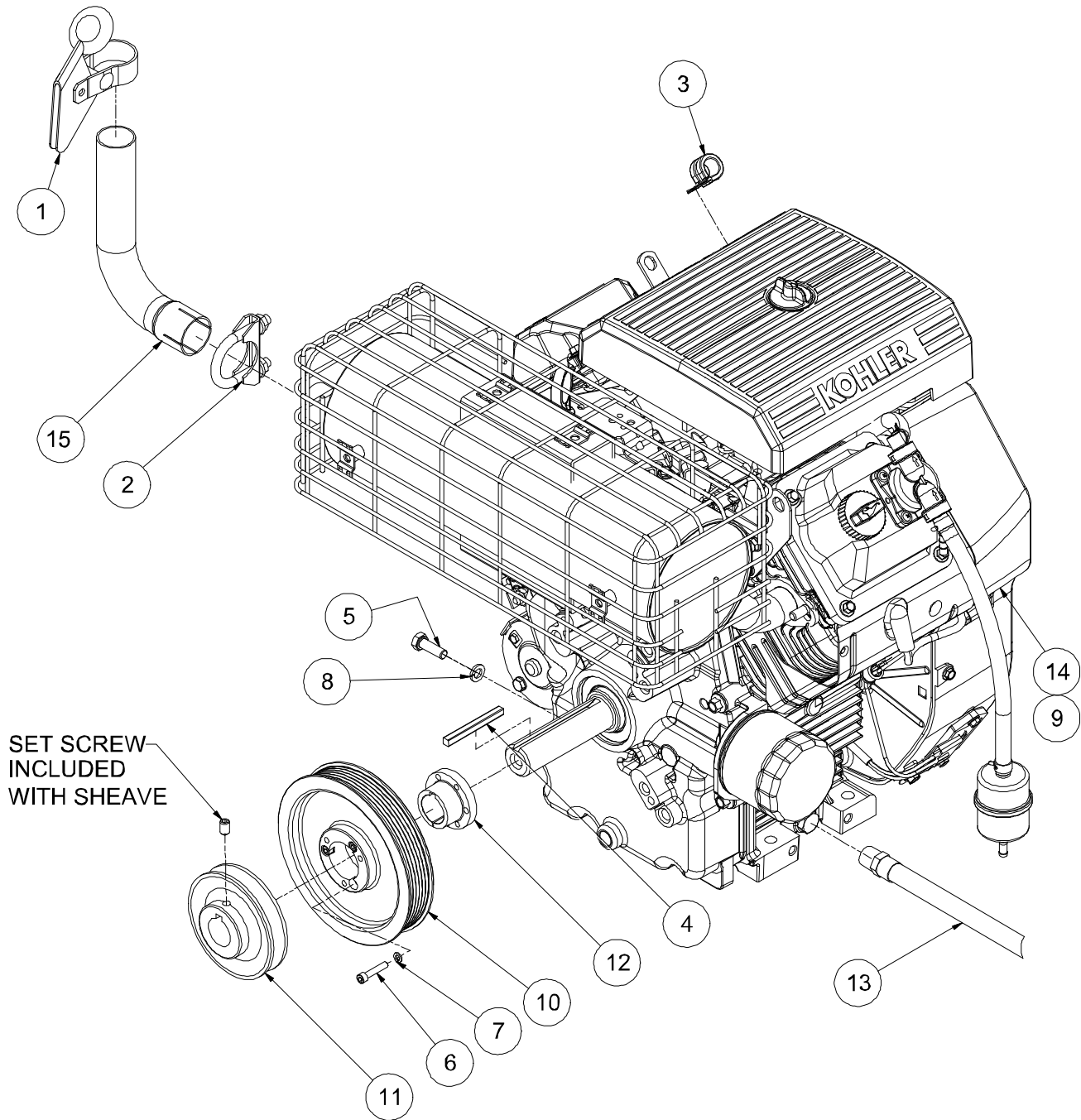

PA6100018-002\_r0

## 7.6B ENGINE AND DRIVE PARTS (ALL REMOTE PANEL MODELS)

ITEM	DESCRIPTION	PART NUMBER	QTY
1	CAP, RAIN 1-1/4" EXHAUST	262706	1
2	CLAMP, EXHAUST 1-1/4 REV.0	262906	1
3	CLAMP, LOOM #010 5/8"	268503	1
4	KEY, SQUARE 1/4 x 1/4 x 2.5	821104-250	1
5	CAPSCREW, HEX M8-1.25 x 25mm	828008-025	1
6	CAPSCREW, S.H. #10-24UNC x 1	828302-100	3
7	WASHER, LOCK #10	838502-047	3
8	WASHER, LOCK METRIC M8	838808-200	1
9	OIL, MOTOR 10W-30	844300-001	2 qts
10	SHEAVE, SERPENTINE, 6 GROOVE	A12924Z	1
11	SHEAVE, SINGLE GROOVE 1"	DR271968	1
12	BUSHING, JA, QD, 1 DIA., 3 BO	DR57469Z	1
13	HOSE, DRAIN 3/8 x 12" LG 3/8NPT	EN22698	1
14	ENGINE, 18HP V-TWIN	EN271037	1
15	TUBE, EXHAUST 1.25 DIA.	TU270889	1

**PLEASE NOTE: WHEN ORDERING PARTS, INDICATE MACHINE SERIAL NUMBER.**

# 7.7 BELT GUARD ASSEMBLY

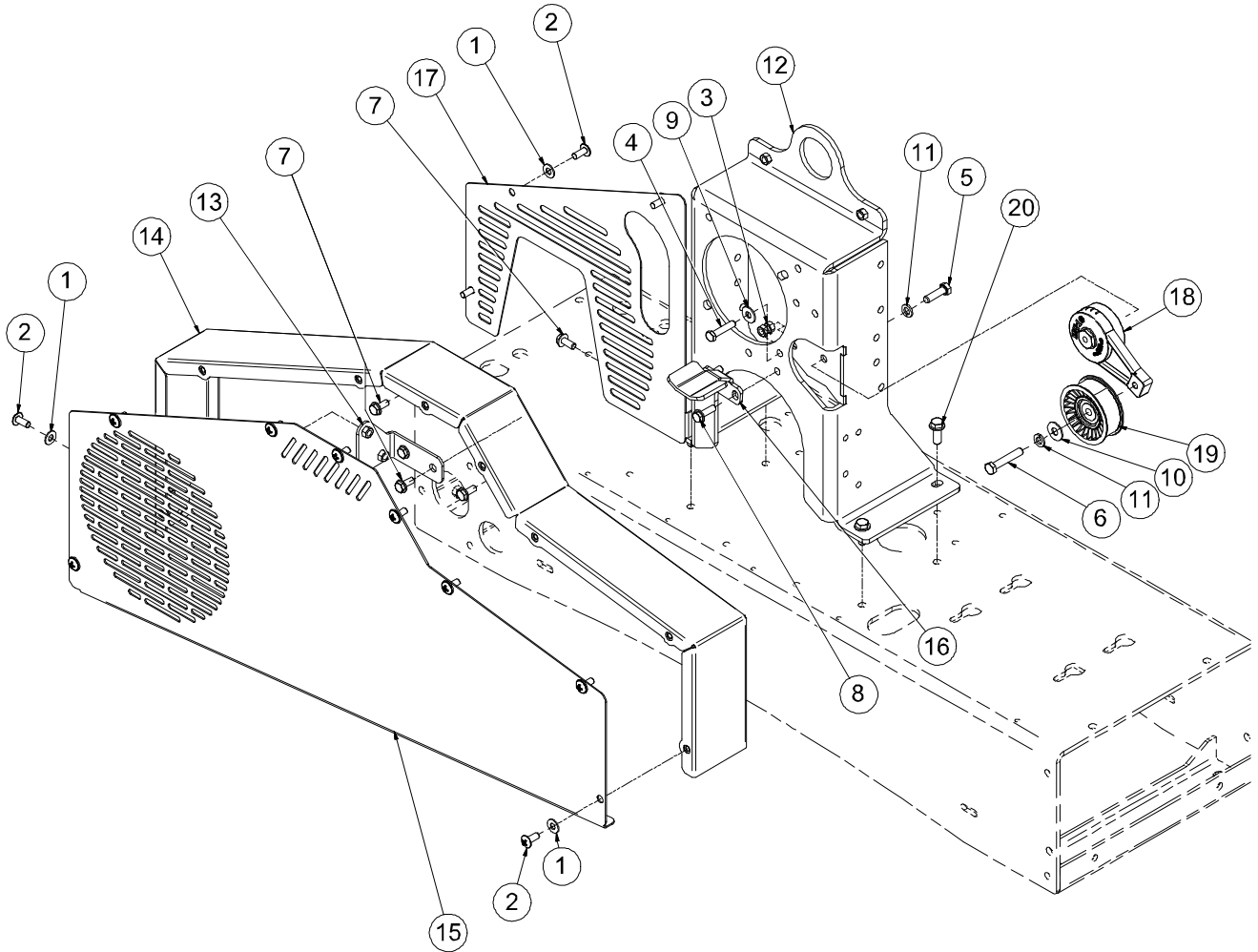

PA6030024-001\_r0



## 7.7 BELT GUARD ASSEMBLY

ITEM	DESCRIPTION	PART NUMBER	QTY
1	WASHER, NYLON 5/16-18	262943	13
2	SCREW, TRUSS HD 5/16-18 x 3/4 SS	262945	13
3	NUT, HEX 5/16-18	825205-273	2
4	CAPSCREW, HEX GR5 5/16-18 x 1.5	829105-150	1
5	CAPSCREW, HEX GR5 3/8-16 x 1-1/4	829106-125	1
6	CAPSCREW, HEX GR5 3/8-16 x	829106-200	1
7	SCREW, SER WASH 5/16-18 x 0.75	829705-075	5
8	SCREW, SER WASH 5/16-18 x 1	829705-100	2
9	WASHER, FLAT 5/16	838205-071	1
10	WASHER, FLAT 3/8	838206-071	1
11	WASHER, LOCK 3/8	838506-094	2
12	WELD TOWER, 8 & 30 GAL	A10758P	1
13	MOUNT, SHIELD	A12291P	1
14	SHIELD, BELT BODY	A1270878	1
15	SHIELD, BELT REAR	A1270879	1
16	DAMPENER, COMPRESSOR BELT	A1270908	1
17	SHIELD, BELT COMPRESSOR	A1272008	1
18	TENSIONER, ROTARY, SMALL	DR25596	1
19	IDLER, 1 WIDTH, 3DIA. FLAT	DR32958	1
20	SCREW, SER WASH 3/8-16 x 1	FA86645	4

**PLEASE NOTE: WHEN ORDERING PARTS, INDICATE MACHINE SERIAL NUMBER.**

# 7.8A ELECTRICAL SYSTEM (ALL MODELS EXCEPT REMOTE PANEL MODELS) 1 OF 2

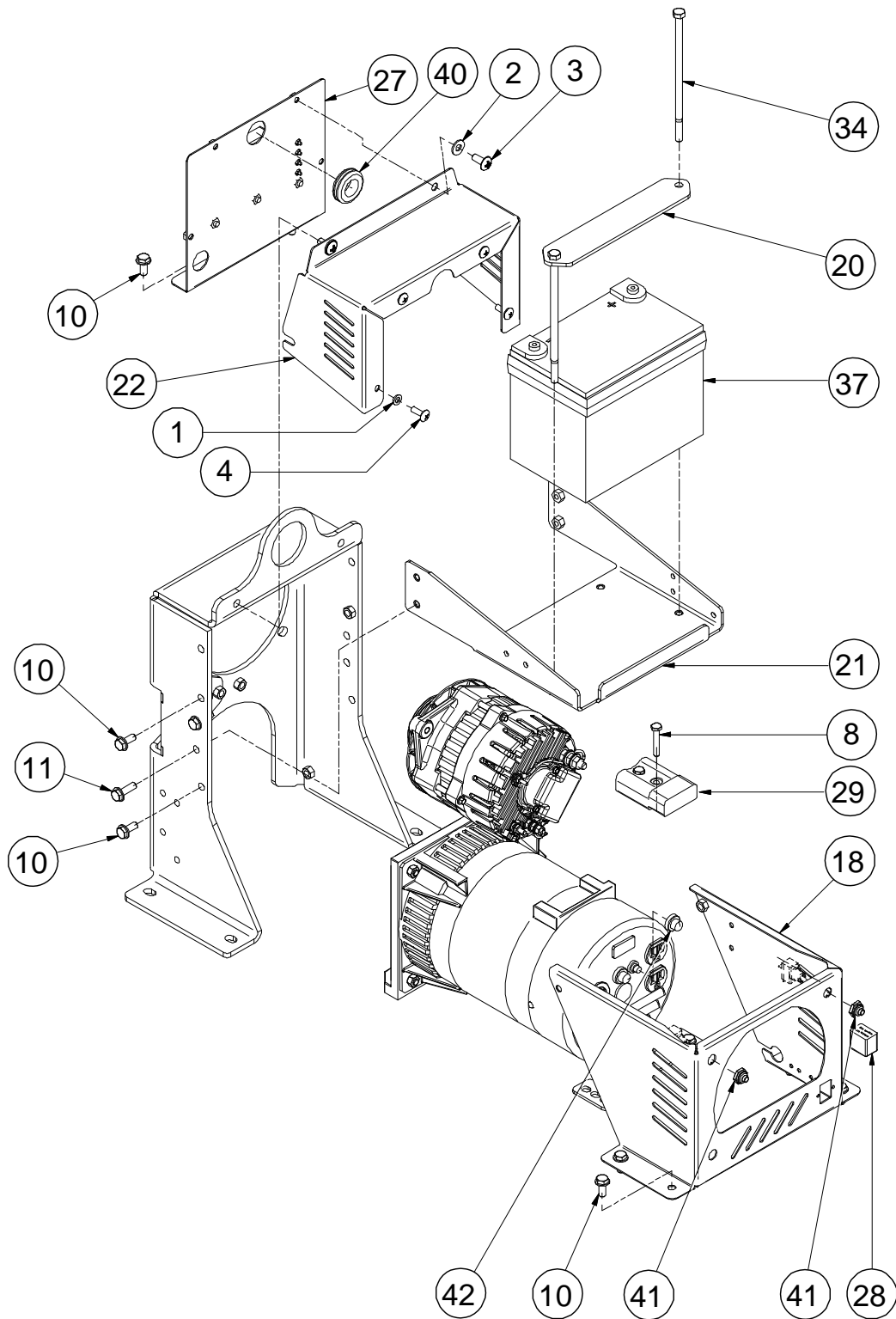

PA6120090-02ID\_r0 (1 of 2)

## 7.8A ELECTRICAL SYSTEM (ALL MODELS EXCEPT REMOTE PANEL MODELS) 1 OF 2

ITEM	DESCRIPTION	PART NUMBER	QTY	ITEM	DESCRIPTION	PART NUMBER	QTY
1	WASHER, NYLON FLAT 1/4	262704	4	22	SHIELD WELDER	A175060	1
2	WASHER, NYLON 5/16-18	262943	2	23	DECAL, ANA GENERATOR ON/OFF	DL269710	1
3	SCREW, TRUSS HD 5/16-18 x 3/4SS	262945	2	24	DECAL, ANA WELDER ON/OFF	DL269711	1
4	SCREW, TRUSS HD 1/4-20UNC x 3/4LG S.S.	262953	4	25	DECAL, ANA 150 AC GEN SERIAL PLATE	DL270613	1
5	KEY, SQUARE 3/16 x 3/6 x 1.5	821103-150	1	26	BUSHING, JA, QD, 7/8 DIA., 3 BO	DR23056Z	1
6	NUT, HEX 3/8-16	825206-337	1	27	MODULE SET, 12V/24V CHARGE	* EA42863	1
7	CAPSCREW, S.H. #10-24UNC x 1	828302-100	3	28	CONNECTOR, SOCKET 6-PIN	EL49193	2
8	CAPSCREW, HEX GR5 1/4-20 x 1-1/2	829104-150	2	29	WELD CABLE ASSY, PRO STAND ALONE	EP42372	1
9	CAPSCREW, HEX GR5 3/8-16 x 3	829106-300	1	30	HARNESS, PRO STAND ALONE PANEL	EP42685	1
10	SCREW, SER WASH 5/16-18 x 0.75	829705-075	10	31	HARNESS, STAND ALONE FUEL LEVEL	EP44840	1
11	SCREW, SER WASH 5/16-18 x 1	829705-100	9	32	BATTERY CABLE, NEGATIVE	EP77939	1
12	WASHER, FLAT 5/16	838205-071	4	33	BATTERY CABLE, POSITIVE	EP93227	1
13	WASHER, FLAT 3/8	838206-071	2	34	CAPSCREW, HEX GR5 5/16-18 x 7	FA31508	2
14	WASHER, LOCK #10	838502-047	3	35	GENERATOR AC, 5,000W	GE269593	1
15	WASHER, LOCK 3/8	838506-094	1	36	WELDER, GENERATOR 150 AMP	GE273695	1
16	WELD TOWER, 8 & 30 GAL	A10758P	1	37	BATTERY, 12 VOLT 35 AMP DEEP	MA31821	1
17	SHEAVE, SERPENTINE, 6 GROOVE	A12924Z	1	38	BATTERY BOOST CABLES-20'	MA36223	1
18	SHIELD, GENERATOR PRO AND CONTRACTOR	A14099P	1	39	WELD CABLES x 20FT., 4 GROUND	MA49835	1
19	MOUNT, REAR GENERATOR	A15865P	1	40	GROMMET, BLACK RUBBER, .875ID	PR22730	1
20	MOUNT, BATTERY INDUSTRIAL, PRO	A16270P	1	41	SWITCH BOOT, TOGGLE, WEATHER PROOF	PR77230	2
21	BATTERY TRAY	A16915P	1	42	BOOT, BREAKER, PANEL MOUNT	PR81817	2

\* **12V BATTERY BOOST OPTION:** replace EA42863 with EA62548.

**WELD ONLY OPTION:** replace EA42863 with EA96353.

**PLEASE NOTE: WHEN ORDERING PARTS, INDICATE MACHINE SERIAL NUMBER.**

# 7.8A ELECTRICAL SYSTEM (ALL MODELS EXCEPT REMOTE PANEL MODELS) 2 OF 2

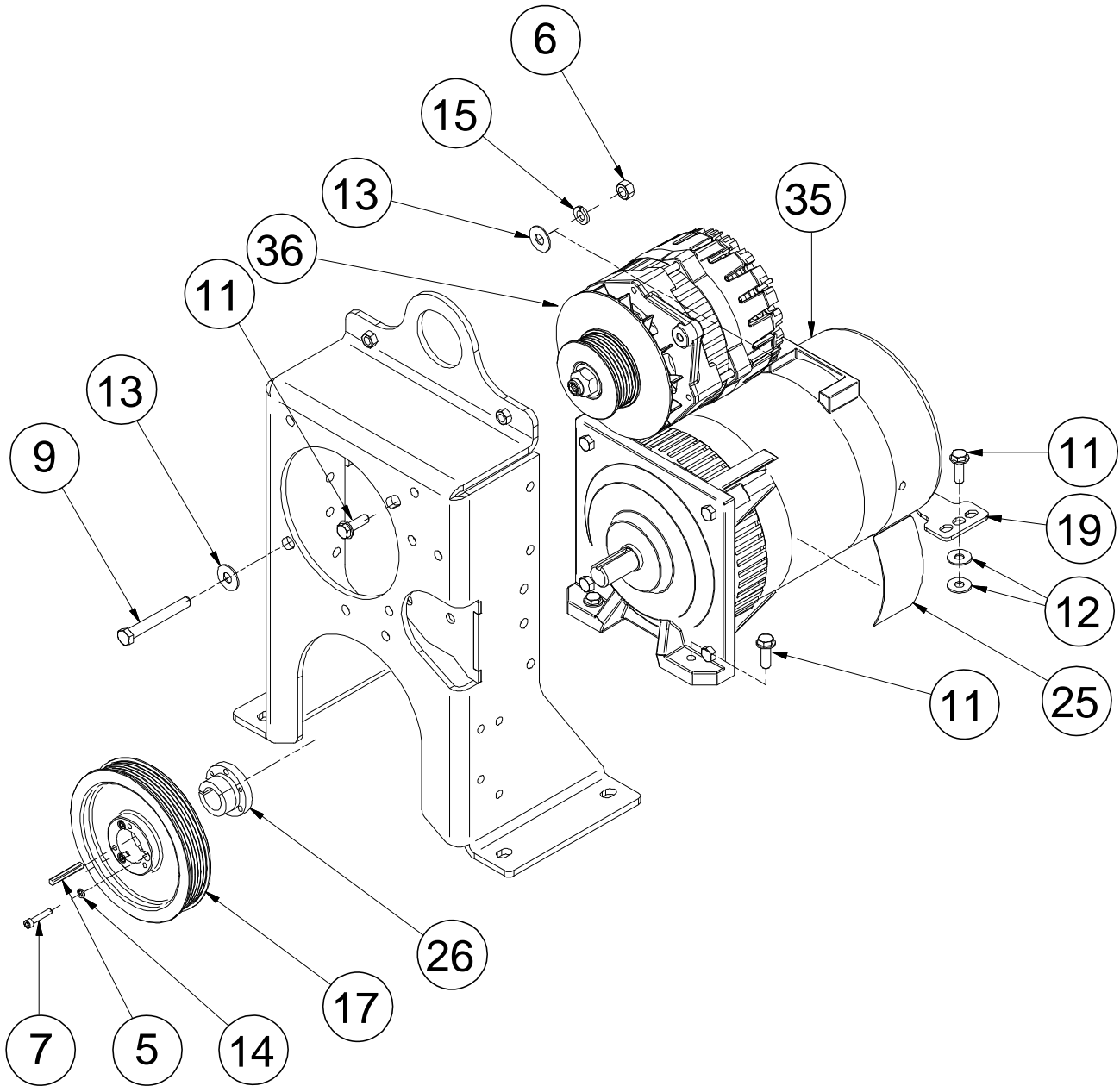

PA6120090-02ID\_r0 (2 of 2)

## 7.8A ELECTRICAL SYSTEM (ALL MODELS EXCEPT REMOTE PANEL MODELS) 2 OF 2

ITEM	DESCRIPTION	PART NUMBER	QTY	ITEM	DESCRIPTION	PART NUMBER	QTY
1	WASHER, NYLON FLAT 1/4	262704	4	22	SHIELD WELDER	A175060	1
2	WASHER, NYLON 5/16-18	262943	2	23	DECAL, ANA GENERATOR ON/OFF	DL269710	1
3	SCREW, TRUSS HD 5/16-18 x 3/4SS	262945	2	24	DECAL, ANA WELDER ON/OFF	DL269711	1
4	SCREW, TRUSS HD 1/4-20UNC x 3/4LG S.S.	262953	4	25	DECAL, ANA 150 AC GEN SERIAL PLATE	DL270613	1
5	KEY, SQUARE 3/16 x 3/6 x 1.5	821103-150	1	26	BUSHING, JA, QD, 7/8 DIA., 3 BO	DR23056Z	1
6	NUT, HEX 3/8-16	825206-337	1	27	MODULE SET, 12V/24V CHARGE	* EA42863	1
7	CAPSCREW, S.H. #10-24UNC x 1	828302-100	3	28	CONNECTOR, SOCKET 6-PIN	EL49193	2
8	CAPSCREW, HEX GR5 1/4-20 x 1-1/2	829104-150	2	29	WELD CABLE ASSY, PRO STAND ALONE	EP42372	1
9	CAPSCREW, HEX GR5 3/8-16 x 3	829106-300	1	30	HARNESS, PRO STAND ALONE PANEL	EP42685	1
10	SCREW, SER WASH 5/16-18 x 0.75	829705-075	10	31	HARNESS, STAND ALONE FUEL LEVEL	EP44840	1
11	SCREW, SER WASH 5/16-18 x 1	829705-100	9	32	BATTERY CABLE, NEGATIVE	EP77939	1
12	WASHER, FLAT 5/16	838205-071	4	33	BATTERY CABLE, POSITIVE	EP93227	1
13	WASHER, FLAT 3/8	838206-071	2	34	CAPSCREW, HEX GR5 5/16-18 x 7	FA31508	2
14	WASHER, LOCK #10	838502-047	3	35	GENERATOR AC, 5,000W	GE269593	1
15	WASHER, LOCK 3/8	838506-094	1	36	WELDER, GENERATOR 150 AMP	GE273695	1
16	WELD TOWER, 8 & 30 GAL	A10758P	1	37	BATTERY, 12 VOLT 35 AMP DEEP	MA31821	1
17	SHEAVE, SERPENTINE, 6 GROOVE	A12924Z	1	38	BATTERY BOOST CABLES-20'	MA36223	1
18	SHIELD, GENERATOR PRO AND CONTRACTOR	A14099P	1	39	WELD CABLES x 20FT., 4 GROUND	MA49835	1
19	MOUNT, REAR GENERATOR	A15865P	1	40	GROMMET, BLACK RUBBER, .875ID	PR22730	1
20	MOUNT, BATTERY INDUSTRIAL, PRO	A16270P	1	41	SWITCH BOOT, TOGGLE, WEATHER PROOF	PR77230	2
21	BATTERY TRAY	A16915P	1	42	BOOT, BREAKER, PANEL MOUNT	PR81817	2

\* 12V BATTERY BOOST OPTION: replace EA42863 with EA62548.

WELD ONLY OPTION: replace EA42863 with EA96353.

**PLEASE NOTE: WHEN ORDERING PARTS, INDICATE MACHINE SERIAL NUMBER.**

# 7.8B ELECTRICAL SYSTEM (ALL REMOTE PANEL MODELS)

## 1 OF 2

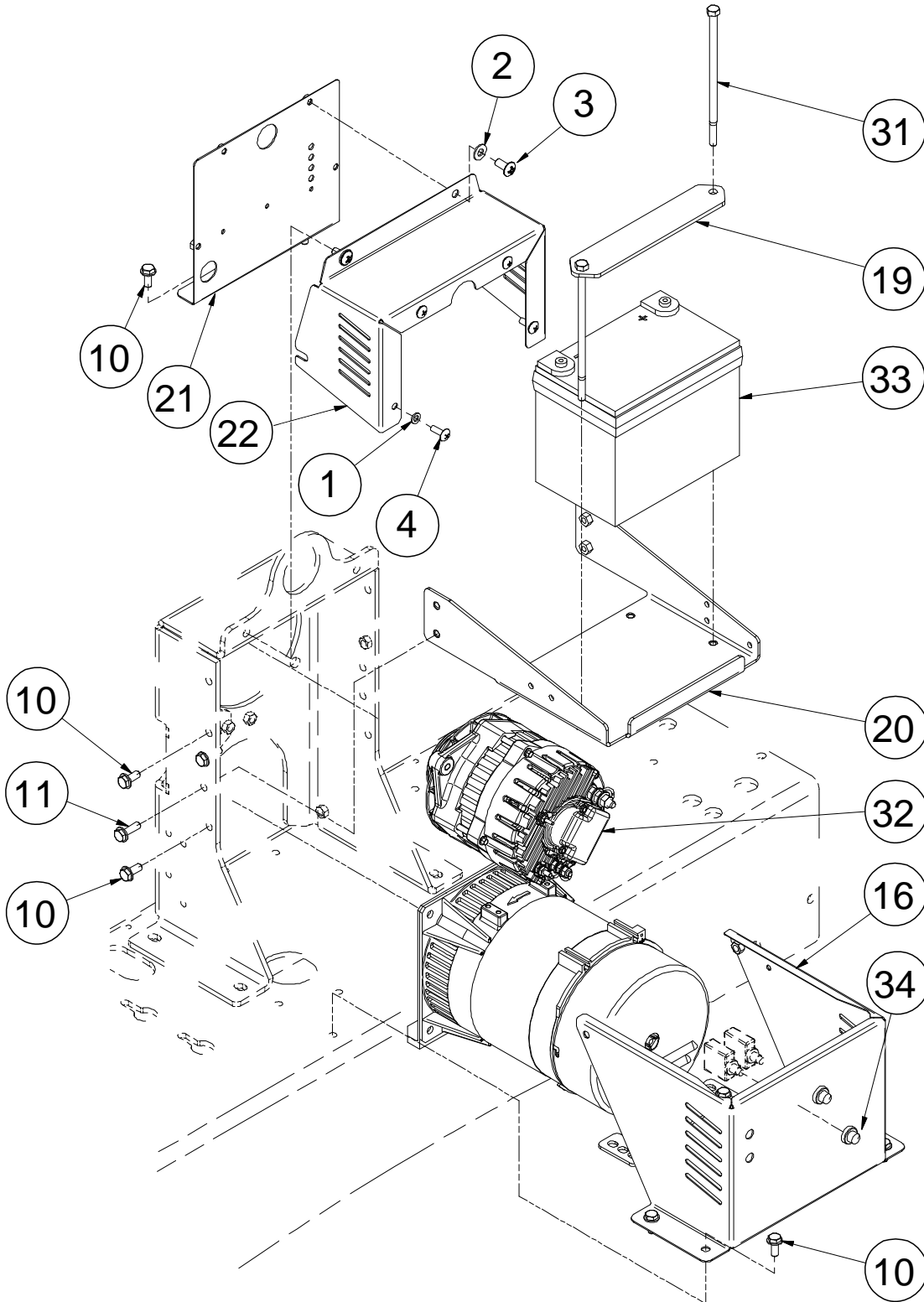

PA6120077-02ID\_r0 (1of2)

## 7.8B ELECTRICAL SYSTEM (ALL REMOTE PANEL MODELS)

### 1 OF 2

ITEM	DESCRIPTION	PART NUMBER	QTY	ITEM	DESCRIPTION	PART NUMBER	QTY
1	WASHER, NYLON FLAT 1/4	262704	4	18	MOUNT, REAR GENERATOR	A15865P	1
2	WASHER, NYLON 5/16-18	262943	2	19	MOUNT, BATTERY INDUSTRIAL, PRO	A16270P	1
3	SCREW, TRUSS HD 5/16-18 x 3/4 SS	262945	2	20	BATTERY TRAY	A16915P	1
4	SCREW, TRUSS HD 1/4-20UNC x 3/4LG S.S.	262953	4	21	MOUNT, MODULE	A17026P	1
5	GENERATOR, 4.2 KW SENTRY	266595	1	22	SHIELD, WELDER	A175060	1
6	KEY, SQUARE 3/16 x 3/16 x 1.5	821103-150	1	23	DECAL, ANA 150 AC GEN SERIAL PLATE	DL270613	1
7	NUT, HEX 3/8-16	826206-337	1	24	BUSHING, JA, QD, 7/8 DIA., 3 BO	DR23056Z	1
8	CAPSCREW, S.H. #10-24UNC x 1	828302-100	3	25	HARNESS, ANA 150 A9HP, REMOTE	EP270920	1
9	CAPSCREW, HEX GR5 3/8-16 x 3	829106-300	1	26	WELD CABLE, REMOTE ASSEMBLY	EP55031	1
10	SCREW, SER WASH 5/16-18 x 0.75	829705-075	10	27	TACH SENSOR WIRE	EP61281	1
11	SCREW, SER WASH 5/16-18 x 1	829705-100	9	28	BATTERY CABLE, NEGATIVE	EP77939	1
12	WASHER, FLAT 5/16	838205-071	4	29	A/C REMOTE HARNESS	EP82587	1
13	WASHER, FLAT 3/8	838206-071	2	30	BATTERY CABLE, POSITIVE	EP93227	1
14	WASHER, LOCK #10	838502-047	3	31	CAPSCREW, HEX GR5 5/16-18 x 7	FA31508	2
15	WASHER, LOCK 3/8	838506-094	1	32	WELDER, GENERATOR 150 AMP	GE273695	1
16	SHIELD, GENERATOR CON & PRO	A11416P	1	33	BATTERY, 12 VOLT 35 AMP DEEP	MA31821	1
17	SHEAVE, SERPENTINE, 6 GROOVE	A12924Z	1	34	BOOT, BREAKER, PANEL MOUNT	PR81817	2

**PLEASE NOTE: WHEN ORDERING PARTS, INDICATE MACHINE SERIAL NUMBER.**

# 7.8B ELECTRICAL SYSTEM (ALL REMOTE PANEL MODELS)

## 2 OF 2

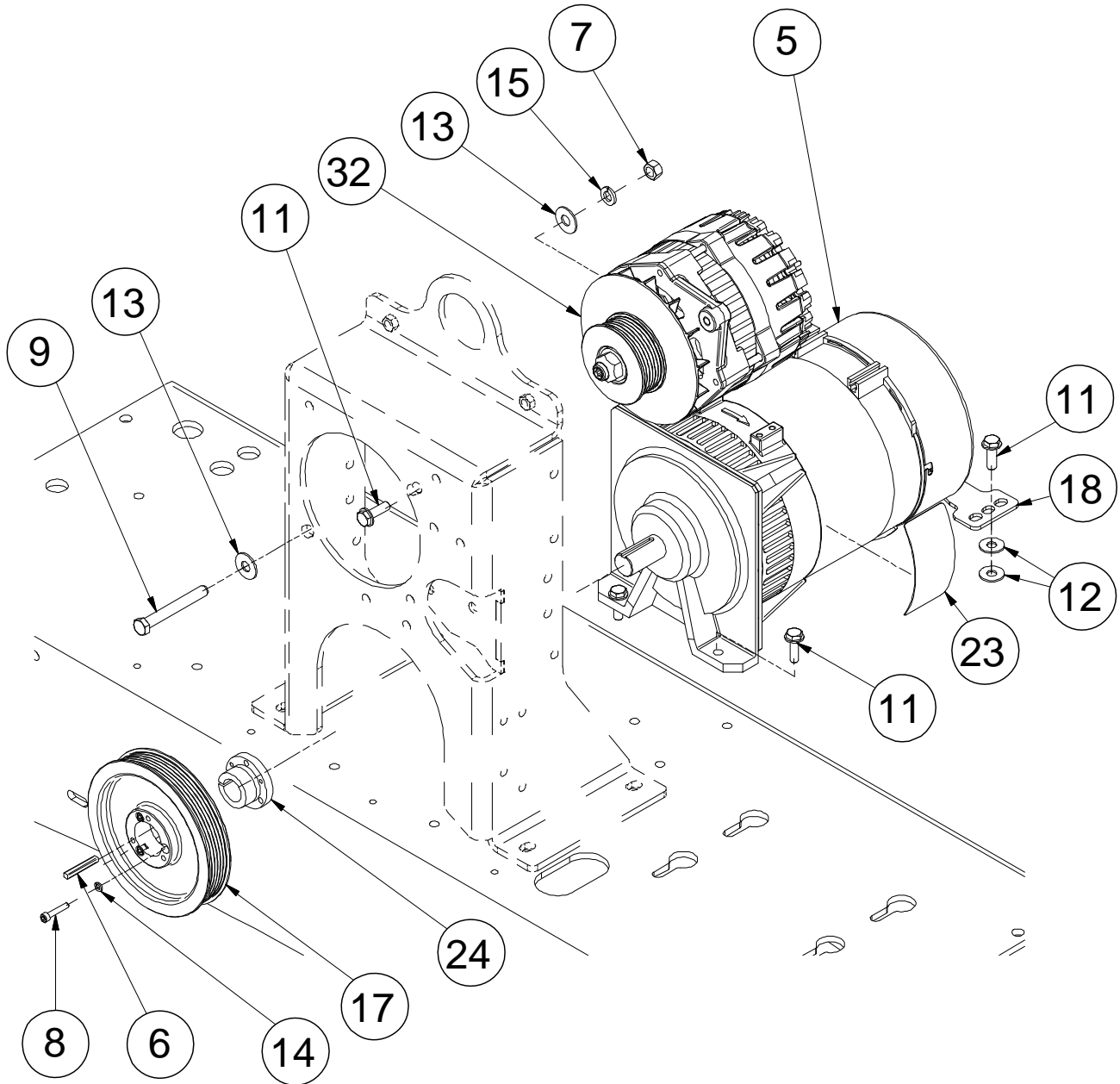

PA6120077-02ID\_r0 (2of2)



## 7.8B ELECTRICAL SYSTEM (ALL REMOTE PANEL MODELS)

### 2 OF 2

ITEM	DESCRIPTION	PART NUMBER	QTY	ITEM	DESCRIPTION	PART NUMBER	QTY
1	WASHER, NYLON FLAT 1/4	262704	4	18	MOUNT, REAR GENERATOR	A15865P	1
2	WASHER, NYLON 5/16-18	262943	2	19	MOUNT, BATTERY INDUSTRIAL, PRO	A16270P	1
3	SCREW, TRUSS HD 5/16-18 x 3/4 SS	262945	2	20	BATTERY TRAY	A16915P	1
4	SCREW, TRUSS HD 1/4-20UNC x 3/4LG S.S.	262953	4	21	MOUNT, MODULE	A17026P	1
5	GENERATOR, 4.2 KW SENTRY	266595	1	22	SHIELD, WELDER	A175060	1
6	KEY, SQUARE 3/16 x 3/16 x 1.5	821103-150	1	23	DECAL, ANA 150 AC GEN SERIAL PLATE	DL270613	1
7	NUT, HEX 3/8-16	826206-337	1	24	BUSHING, JA, QD, 7/8 DIA., 3 BO	DR23056Z	1
8	CAPSCREW, S.H. #10-24UNC x 1	828302-100	3	25	HARNESS, ANA 150 A9HP, REMOTE	EP270920	1
9	CAPSCREW, HEX GR5 3/8-16 x 3	829106-300	1	26	WELD CABLE, REMOTE ASSEMBLY	EP55031	1
10	SCREW, SER WASH 5/16-18 x 0.75	829705-075	10	27	TACH SENSOR WIRE	EP61281	1
11	SCREW, SER WASH 5/16-18 x 1	829705-100	9	28	BATTERY CABLE, NEGATIVE	EP77939	1
12	WASHER, FLAT 5/16	838205-071	4	29	A/C REMOTE HARNESS	EP82587	1
13	WASHER, FLAT 3/8	838206-071	2	30	BATTERY CABLE, POSITIVE	EP93227	1
14	WASHER, LOCK #10	838502-047	3	31	CAPSCREW, HEX GR5 5/16-18 x 7	FA31508	2
15	WASHER, LOCK 3/8	838506-094	1	32	WELDER, GENERATOR 150 AMP	GE273695	1
16	SHIELD, GENERATOR CON & PRO	A11416P	1	33	BATTERY, 12 VOLT 35 AMP DEEP	MA31821	1
17	SHEAVE, SERPENTINE, 6 GROOVE	A12924Z	1	34	BOOT, BREAKER, PANEL MOUNT	PR81817	2

**PLEASE NOTE: WHEN ORDERING PARTS, INDICATE MACHINE SERIAL NUMBER.**

# 7.9A AIR STORAGE ASSEMBLY (ALL 8 GALLON, STAND ALONE AND REMOTE PANEL MODELS)

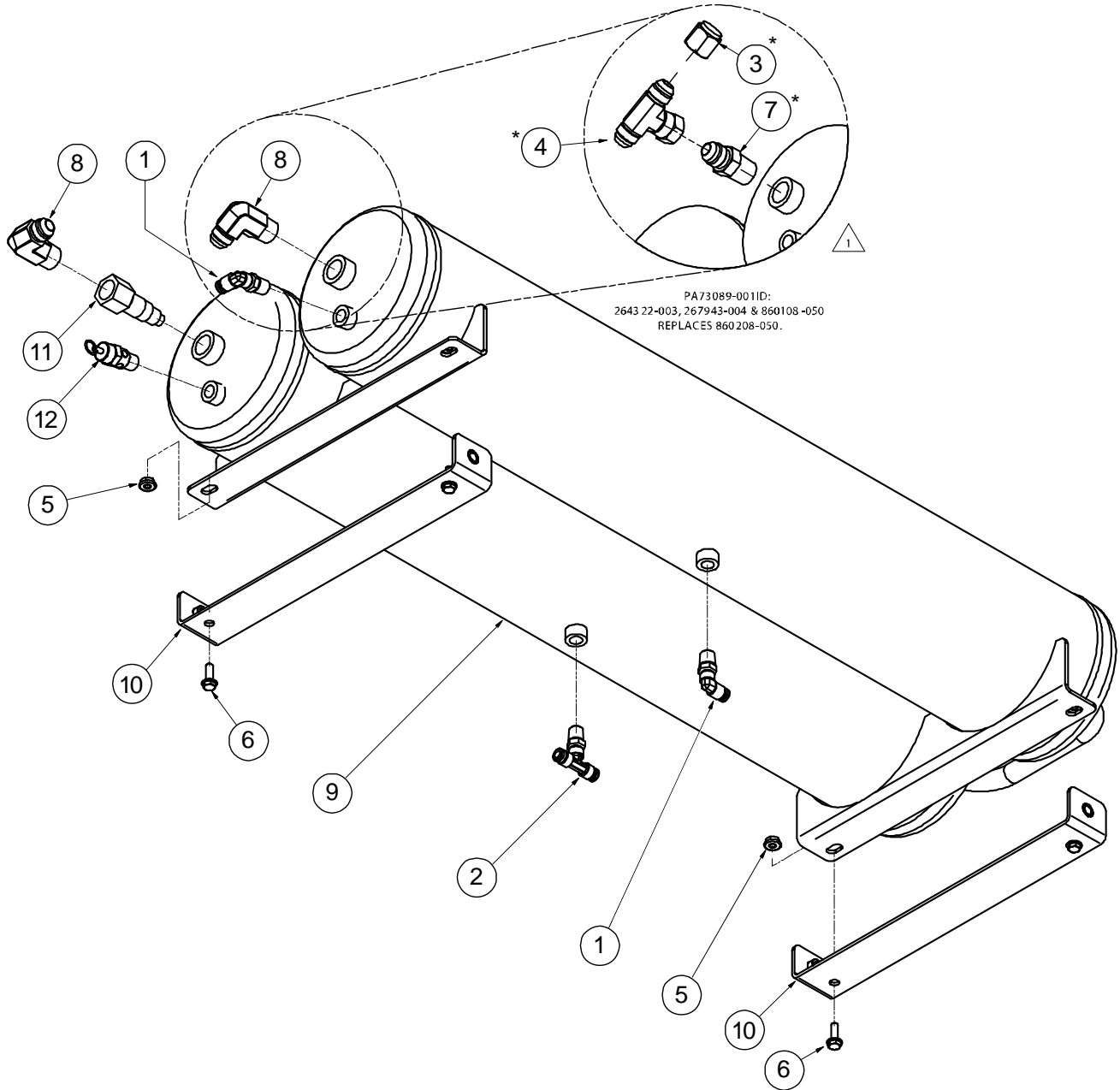

PA73089ID\_r1

## 7.9A AIR STORAGE ASSEMBLY (ALL 8 GALLON, STAND ALONE AND REMOTE PANEL MODELS)

ITEM	DESCRIPTION	PART NUMBER	QTY
1	ELBOW, 90 DEG. PUSH ON 1/4T x 1/4P	261310	2
2	TEE, 1/4P x 1/4 T	261313	1
3	CAP, FEMALE JIC 3/4-16 #8	264322-003*	1
4	TEE, SWIVEL JIC FxMxM #8	267943-004*	1
5	NUT, HEX FLANGE 1/4-20	825304-236	4
6	SCREW, SER WASH 1/4-20 x 0.75	829704-075	4
7	CONNECTOR, 37FL/MPT #08 x 1/2	860108-050*	1
8	ELBOW, 37FL/90M #08 x 1/2	860208-050	2
9	TANK, DUAL 8-GAL TOTAL	A12578P	1
10	MOUNT, AIR TANKS	A18801P	2
11	VALVE, CHECK 1/2 NPT M-F	CO35980	1
12	VALVE, RELIEF 150 PSI 1/4 NPT MALE	CO93614	1

**PLEASE NOTE: WHEN ORDERING PARTS, INDICATE MACHINE SERIAL NUMBER.**

### 7.9B AIR STORAGE ASSEMBLY (ALL 30 GALLON, STAND ALONE MODELS)

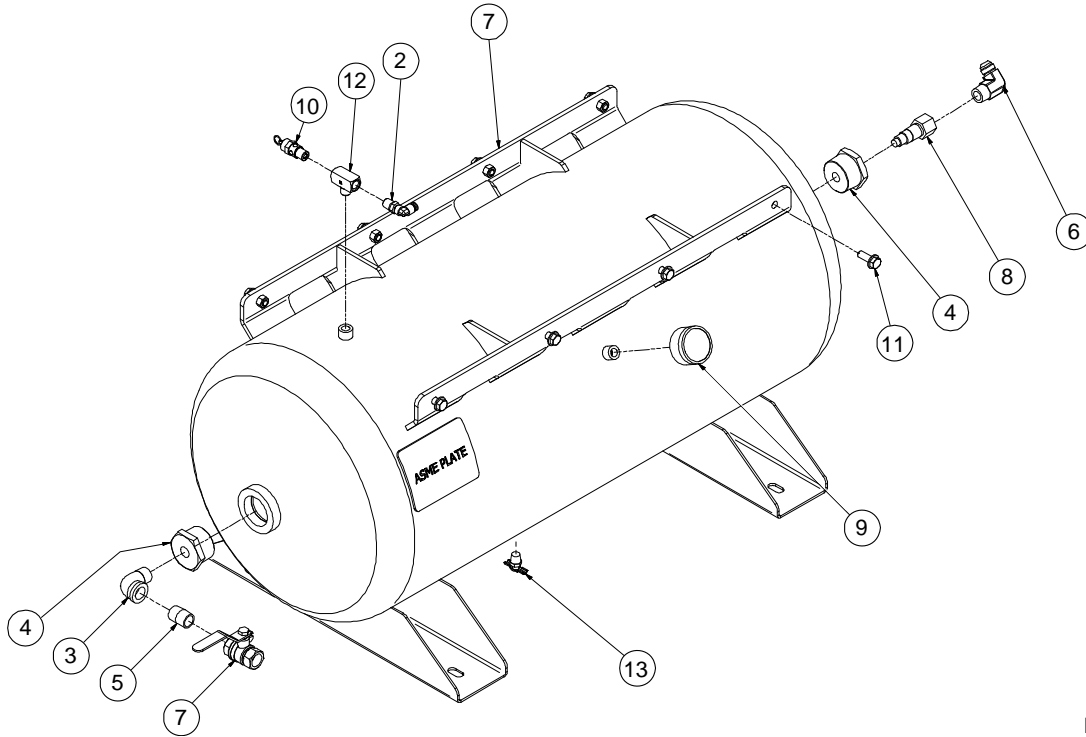

PA89907ID\_r2

### 7.9C AIR STORAGE ASSEMBLY (ALL 30 GALLON REMOTE PANEL MODELS)

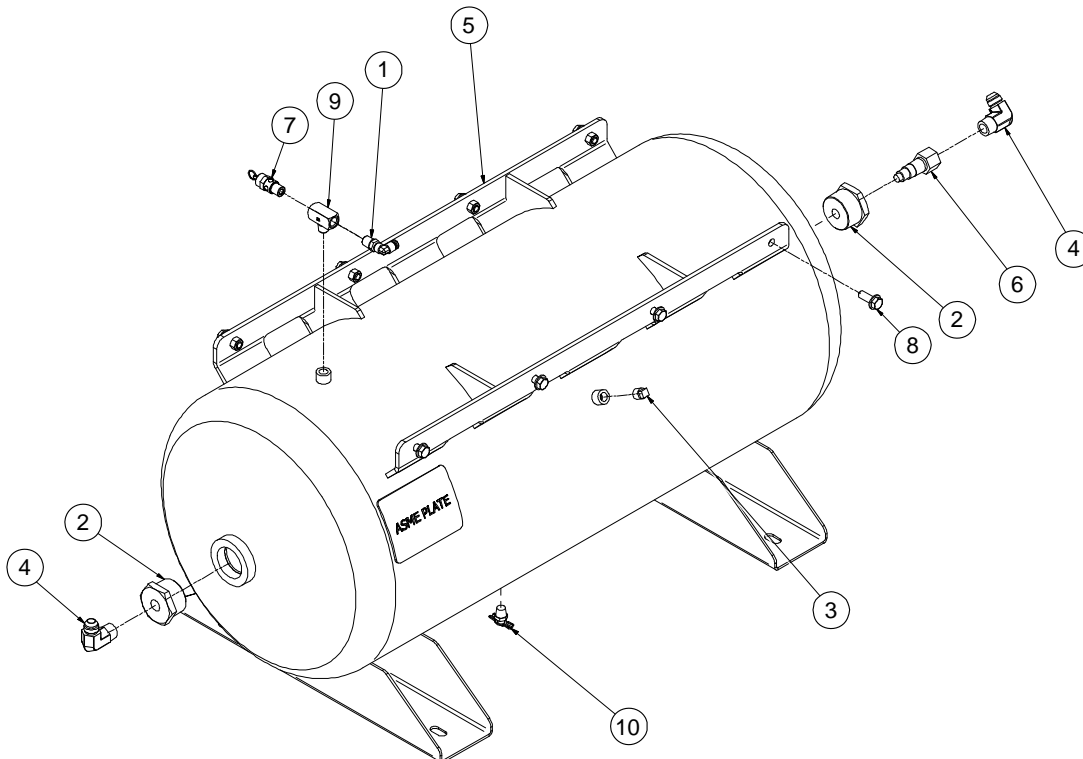

PA23932ID\_r1

## 7.9B AIR STORAGE ASSEMBLY (ALL 30 GALLON, STAND ALONE MODELS)

ITEM	DESCRIPTION	PART NUMBER	QTY
1	VALVE, SERVICE 1/2	260448	1
2	ELBOW, 90 DEG. PUSH-ON 1/4T x 1/4P	261310	1
3	ELBOW, PIPE STREET 1/2	801115-020	1
4	BUSHING, PIPE GALV 1-1/2 x 1/2	804106-020	2
5	NIPPLE, PIPE XS CLOSE 1/2	822208-000	1
6	ELBOW, 37FL/90M #08 x 1/2	860208-050	1
7	TANK, 30 GAL, W/RAILS	A18443P	1
8	VALVE, CHECK 1/2 NPT M-F	CO35980	1
9	GAUGE, AIR DRY 0-200 PSI	CO47028	1
10	VALVE, RELIEF 150 PSI 1/4 NPT MALE	CO93614	1
11	SCREW, SER WASH 3/8-16 x 1	FA86645	8
12	TEE, BRASS BRANCH TEE 1/4" NPT	FI41491	1
13	VALVE, PETCOCK VALVE, 1/4 NPT	FI74953	1

**PLEASE NOTE: WHEN ORDERING PARTS, INDICATE MACHINE SERIAL NUMBER.**

## 7.9C AIR STORAGE ASSEMBLY (ALL 30 GALLON REMOTE PANEL MODELS)

ITEM	DESCRIPTION	PART NUMBER	QTY
1	ELBOW, 90 DEG. PUSH ON 1/4T x 1/4P	261310	1
2	BUSHING, PIPE GALV 1-1/2 x 1/2	804106-020	2
3	PLUG, PIPE 1/4	807800-010	1
4	ELBOW, 37FL/90M #08 x 1/2	860208-050	2
5	TANK, 30 GAL, W/RAILS	A18443P	1
6	VALVE, CHECK 1/2 NPT M-F	CO35980	1
7	VALVE, RELIEF 150 PSI 1/4 NPT MALE	CO93614	1
8	SCREW, SER WASH 3/8-16 x 1	FA86645	8
9	TEE, BRASS BRANCH TEE	FI41491	1
10	VALVE, PETCOCK VALVE, 1/4 NPT	FI74953	1

**PLEASE NOTE: WHEN ORDERING PARTS, INDICATE MACHINE SERIAL NUMBER.**



## 7.10A FUEL TANK ASSEMBLY (ALL 8 GALLON MODELS)

ITEM	DESCRIPTION	PART NUMBER	QTY
1	SWITCH, LIQUID LEVEL SIDE MOUNT	269203	1
2	TUBE, FUEL PICK-UP	269359	1
3	VALVE, ROLLOVER FUEL VENT 1/2 NPT	270956	1
4	NUT, HEX FLANGE 5/16-18	825305-283	4
5	O-RING, VITON 11/16 x 1/8	826501-209	1
6	SCREW, SER WASH 1/4-20 x 0.5	829704-050	1
7	SCREW, SER WASH 5/16-18 x 0.75	829705-075	4
8	HOSE, FUEL 5/16 SAE 30R7 x 10" LG	842315-031	1
9	TANK, FUEL 4.5 GAL, TETHERED	A1271616	1
10	DECAL, NO E85 GAS CAP LOGO	DL270183	1
11	CLAMP, HOSE, T-BOLT STYLE, 13mm SS	FA38355	4
12	CLAMP, HOSE, T-BOLT STYLE	FA66533	2
13	HOSEBARB, 1/4NPT x 5/16 BRASS	FI271131	1
14	ELBOW, PIPE BRASS 1/2 NPT	FI77644	1
15	PLUG, PIPE 1/4	FI87905	1
16	PUSH-ON, MALE ADAPTER, 1/4 MALE x 3/16 PUSH	FI92363	1
17	CAP, GAS VENTED TETHERED	HA271571	1
18	HOSE, FUEL 1/4 SAE 30R9 x 18" LG	TU269439	1
19	HOSE, FUEL 3/16 SAE 30R7 x 8" LG	TU28641	1

**PLEASE NOTE: WHEN ORDERING PARTS, INDICATE MACHINE SERIAL NUMBER.**





## 7.10B FUEL TANK ASSEMBLY (ALL 30 GALLON MODELS)

ITEM	DESCRIPTION	PART NUMBER	QTY
1	SWITCH, LIQUID LEVEL SIDE MOUNT	269203	1
2	VALVE, ROLLOVER FUEL VENT 1/2 NPT	270956	1
3	O-RING, VITON 11/16 x 1/8	826502-209	1
4	SCREW, SER WASH 1/4-20 x 0.5	829704-050	1
5	HOSE, FUEL 5/16 SAE 30R7 x 10" LG	842315-031	1
6	TUBE, FUEL PICK UP	A1270944	1
7	TANK, FUEL EXTENDED RUN TETHERED	A1271617	1
8	DECAL, NO E85 GAS CAP LOGO	DL270183	1
9	CLAMP, HOSE, T-BOLT STYLE 13mm SS	FA38355	4
10	CLAMP, HOSE, T-BOLT STYLE	FA66533	2
11	HOSEBARB, 1/4FNPT x 5/16 BRASS	FI271131	1
12	ELBOW, PIPE BRASS 1/2 INCH NPT	FI77644	1
13	PLUG, PIPE 1/4	FI87905	1
14	PUSH-ON, MALE ADAPTER, 1/4 MALE x 3/16 PUSH	FI92363	1
15	CAP, GAS VENTED TETHERED	HA271571	1
16	HOSE, FUEL 5/16 SAE 30R9 x 18" LG	TU270137	1
17	HOSE, FUEL 3/16 SAE 30R7 x 8" LG	TU27641	1

**PLEASE NOTE: WHEN ORDERING PARTS, INDICATE MACHINE SERIAL NUMBER.**

## 7.10C FUEL TANK ASSEMBLY (ALL FUEL PUMP/REMOTE MODELS)

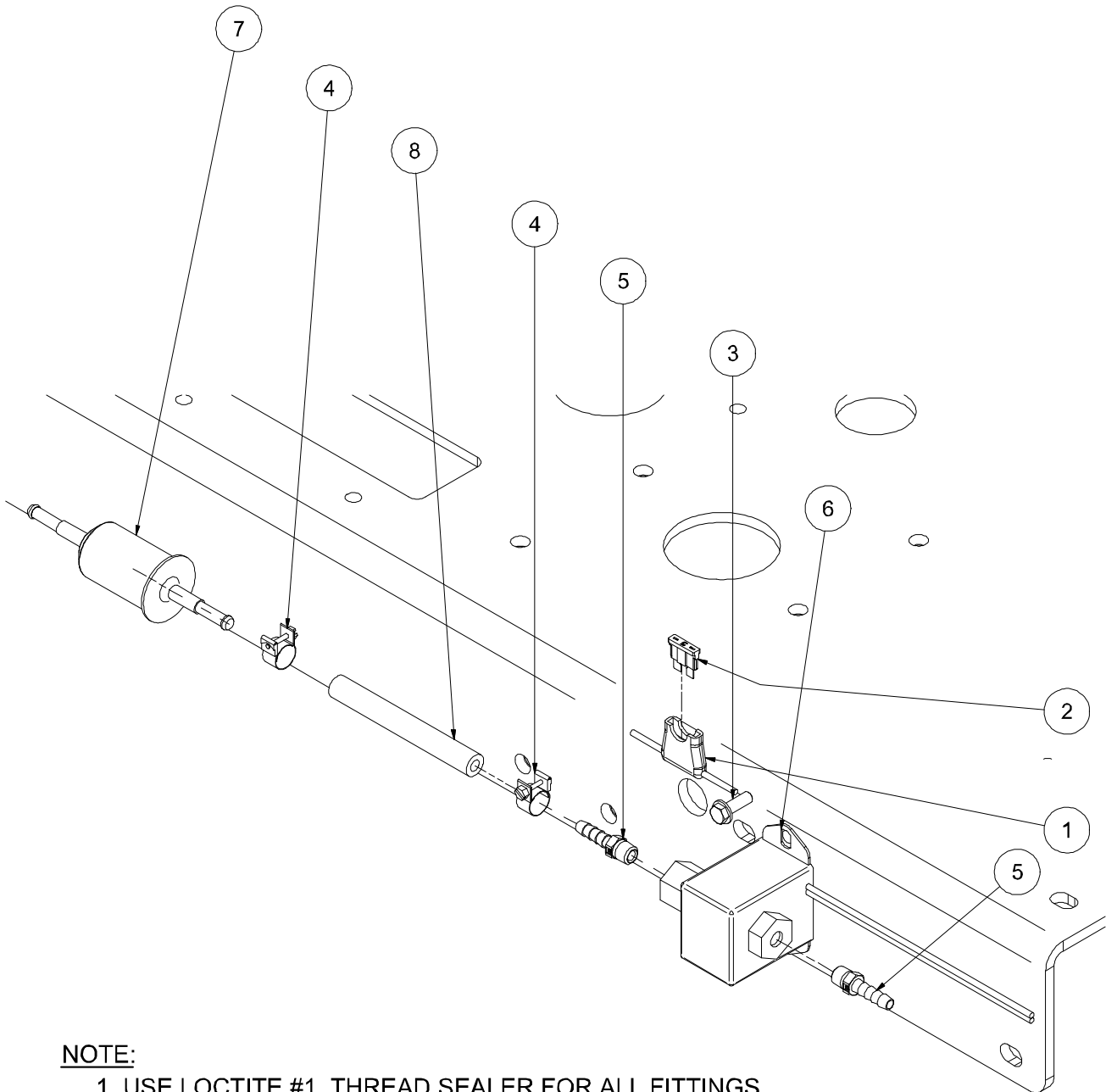

PA6140009ID\_r0

## 7.10C FUEL TANK ASSEMBLY (ALL FUEL PUMP/REMOTE MODELS)

ITEM	DESCRIPTION	PART NUMBER	QTY
1	HOLDER, FUSE ATC STYLE	263172	1
2	FUSE, ATC 5 AMP TAN	263532	1
3	SCREW, SER WASH 1/4-20 x 0.75	829704-075	2
4	CLAMP, HOSE, T-BOLT STYLE, 13mm SS	FA38355	2
5	HOSEBARB, 1/8" MNPT X 1/4 BRASS	FI57609	2
6	FUEL PUMP, 12V SOLID STATE, 1.5-2.5 PSI	MA53288	1
7	FILTER, INLINE FUEL 1/4-5/16"	RC81465	1
8	HOSE, FUEL 1/4" X 4" LG. SAE 30R9	TU269439	1

**PLEASE NOTE: WHEN ORDERING PARTS, INDICATE MACHINE SERIAL NUMBER.**

# 7.11 DECAL LOCATIONS

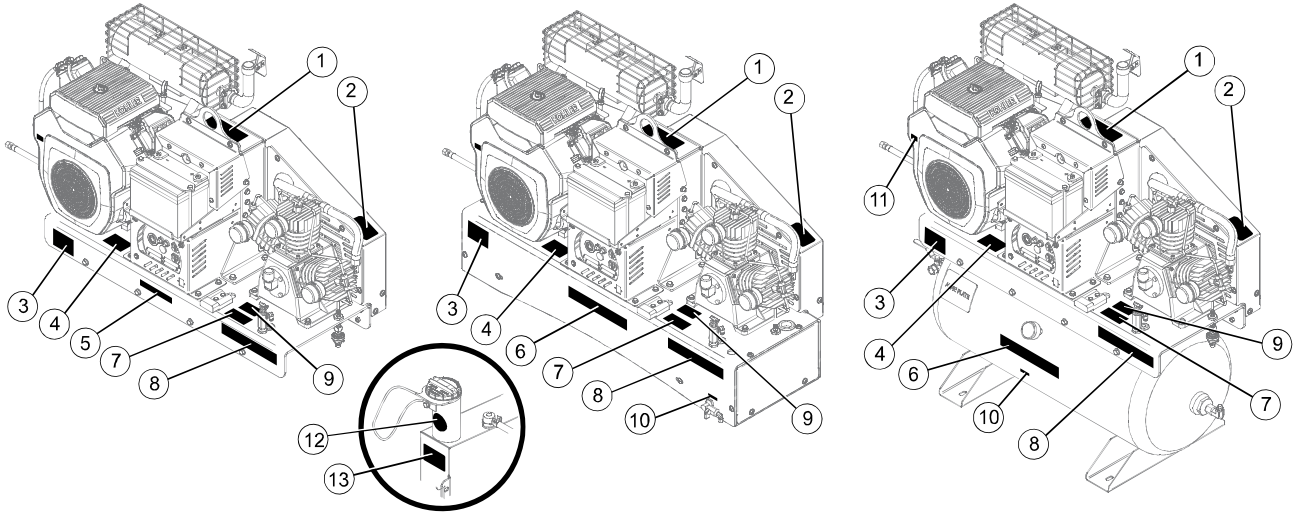

**VAN AIR**  
AIR POWER TO GO™  
1-800-526-8817  
www.vanair.com

Only Replace With  
PowerTwist Plus V-Belts As Below:

**A**      **100**  
SECTION      NUMBER OF LINKS

Contact Vanair Mfg. at 800-526-8817  
to purchase replacement belts.

**CAUTION**

- \* REVIEW OWNER'S MANUAL BEFORE OPERATING MACHINE.
- \* DO NOT OPERATE MACHINE OR WELD NEAR FLAMMABLE MATERIALS.
- \* USE ADEQUATE VENTILATION WHILE OPERATING MACHINE.
- \* WEAR PROPER PROTECTIVE CLOTHING, GLOVES, HELMET, EYE PROTECTION AND EAR PROTECTION.
- \* KEEP AWAY FROM MOVING PARTS. DO NOT OPERATE WITH SAFETY SHIELDS REMOVED.
- \* WELDING FUMES MAY BE TOXIC.
- \* MACHINE PRODUCES ARC FLASH. WEAR A WELDING HELMET WITH SHADE OF 10 OR HIGHER.

**NOTICE**

GENERATOR SWITCH SERVES ONLY AS A THROTTLE CONTROL - CIRCUITS ARE ALWAYS HOT.

Air N Arc™  
ALL-IN-ONE Power Systems™

www.vanair.com  
800-526-8817

Air N Arc®      www.vanair.com  
(800) 526-8817

**VAN AIR**      ALL-IN-ONE Power Systems®      MADE IN THE USA

**VAN AIR**  
POWER TO GO™

800-526-8817  
www.vanair.com

VAN AIR

MODEL NUMBER \_\_\_\_\_

SERIAL NUMBER \_\_\_\_\_

MAXIMUM PRESSURE \_\_\_\_\_

COMPRESSOR INPUT RPM \_\_\_\_\_

260940

**DANGER**

DO NOT WELD WITH THE ELECTRODE HOLDER CONNECTED TO THE NEGATIVE (-) PORT AND THE WORK PIECE CONNECTED TO THE VEHICLE. BODILY HARM AND EQUIPMENT DAMAGE MAY OCCUR.

**150A      5KW      20CFM**

**AIR N ARC 150**

**AIR TANK DRAIN**  
Drain Daily

EMISSION CONTROL INFORMATION

**VAN AIR**  
POWER TO GO™

DATE OF MANUFACTURE: MONTH/YEAR

THIS EQUIPMENT MEETS U.S. EPA EVAP STANDARDS

EQUIPMENT FAMILY - DVANPNHEGAS

271790-013

**DANGER**

DO NOT WELD WITH THE ELECTRODE HOLDER CONNECTED TO THE NEGATIVE (-) PORT AND THE WORK PIECE CONNECTED TO THE VEHICLE. BODILY HARM AND EQUIPMENT DAMAGE MAY OCCUR.

**WARNING**

FILL ON LEVEL SURFACE  
DO NOT OVERFILL  
OR TOP OFF FUEL.  
DAMAGE MAY OCCUR



## 7.11 DECAL LOCATIONS

ITEM	DESCRIPTION	PART NUMBER	QTY
1	DECAL, VANAIR LOGO CONTACT INFO	DL269675	1
2	DECAL, POWERTWIST BELT INFO	DL269690	1
3	DECAL, CAUTION WARNING	DL270120	1
4	DECAL, NOTICE SWITCHES	DL270119	1
5	DECAL, INFO VANAIR	DL271081	1
6	DECAL, MAIN LOGO WHITE	272146	1
7	PLATE, SERIAL NO VANAIR	260940	1
8	DECAL, ANA PERF BADGE	DL269673	1
9	DECAL, DANGER DO NOT WELD	DL273673	<i>II</i>
10	DECAL, AIR TANK DRAIN WHITE	DL269676	1
11	DECAL, NO E85 GAS CAP	DL270183	1
12	LABEL, EPA EMISSIONS	271790-13	1
13	DECAL, WARNING DO NOT TOP OFF	272649	1

<sup>I</sup> Decal locations for skid-mount model are the same as decals #1, 2, 3, 4 and 7 above. Decals #5, 6 and 8 will vary in accordance with customer air tank installation, but are suggested to use similar approach to that shown in the figure.

<sup>II</sup> Some models come equipped with two of these decals: the larger of the two is located as shown; the smaller one, if applicable, may typically be placed on, or in close proximity to, the remote panel.

**PLEASE NOTE: WHEN ORDERING PARTS, INDICATE MACHINE SERIAL NUMBER.**

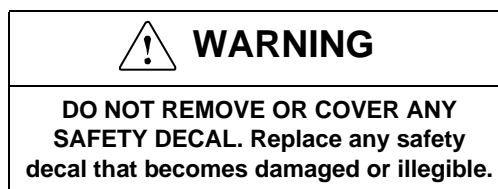



# 7.13 WIRING DIAGRAM - AIR N ARC 150 - REMOTE PANEL

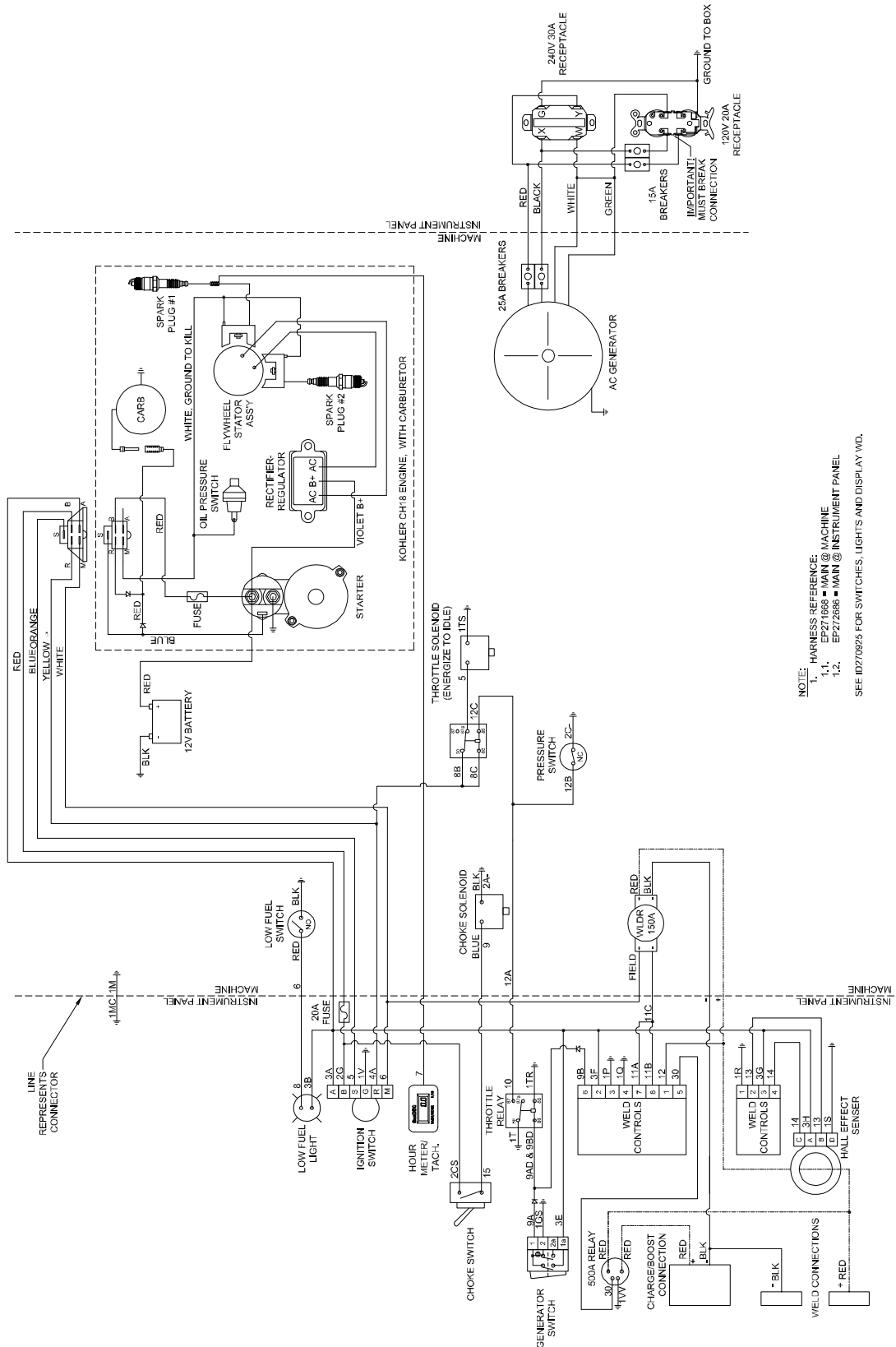

NOTE:  
1. HARNESS REFERENCE:  
1.1. EP271668 = MAIN @ MACHINE  
1.2. EP272686 = MAIN @ INSTRUMENT PANEL  
SEE ID270825 FOR SWITCHES, LIGHTS AND DISPLAY W/D.

# 7.14 FLOW SCHEMATIC DIAGRAM (1 OF 4)

PARTS LIST			
ITEM	PART NUMBER	DESCRIPTION	QTY
1	260448	VALVE, SERVICE 1/2	1
2	260818	SWITCH, PRESSURE N.C. 10 PSI HOBBS	1
3	CO25331	VALVE, PILOT, 95-125 PSI, 1/4	1
4	CO47028	GAUGE, AIR DRY 0-200 PSI	1
5	PA6010076-0011D	COMPRESSOR, ANA 150	1

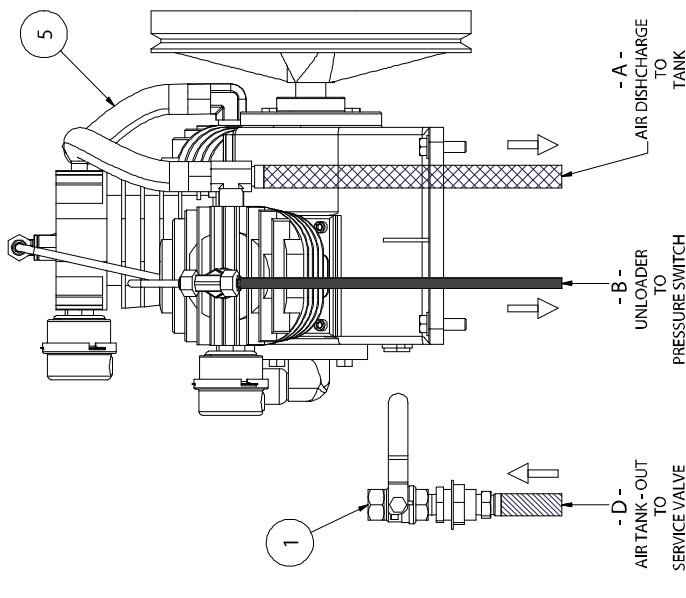
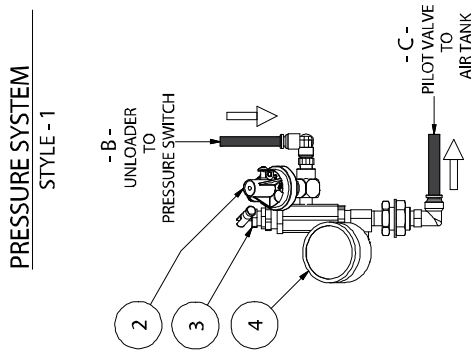
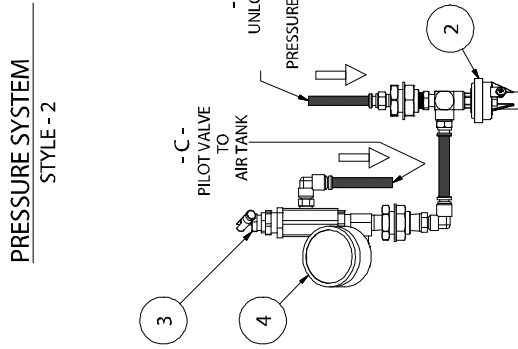

**NOTES:**  
1. PART NUMBERS IN BOM ARE SHOWN FOR REFERENCE.

- AIR TANK - IN
- PRESSURE SYS.
- AIR CONDENSATE
- AIR TANK - OUT

ID274888\_r0(1of4)



### 7.14 FLOW SCHEMATIC DIAGRAM (2 OF 4)

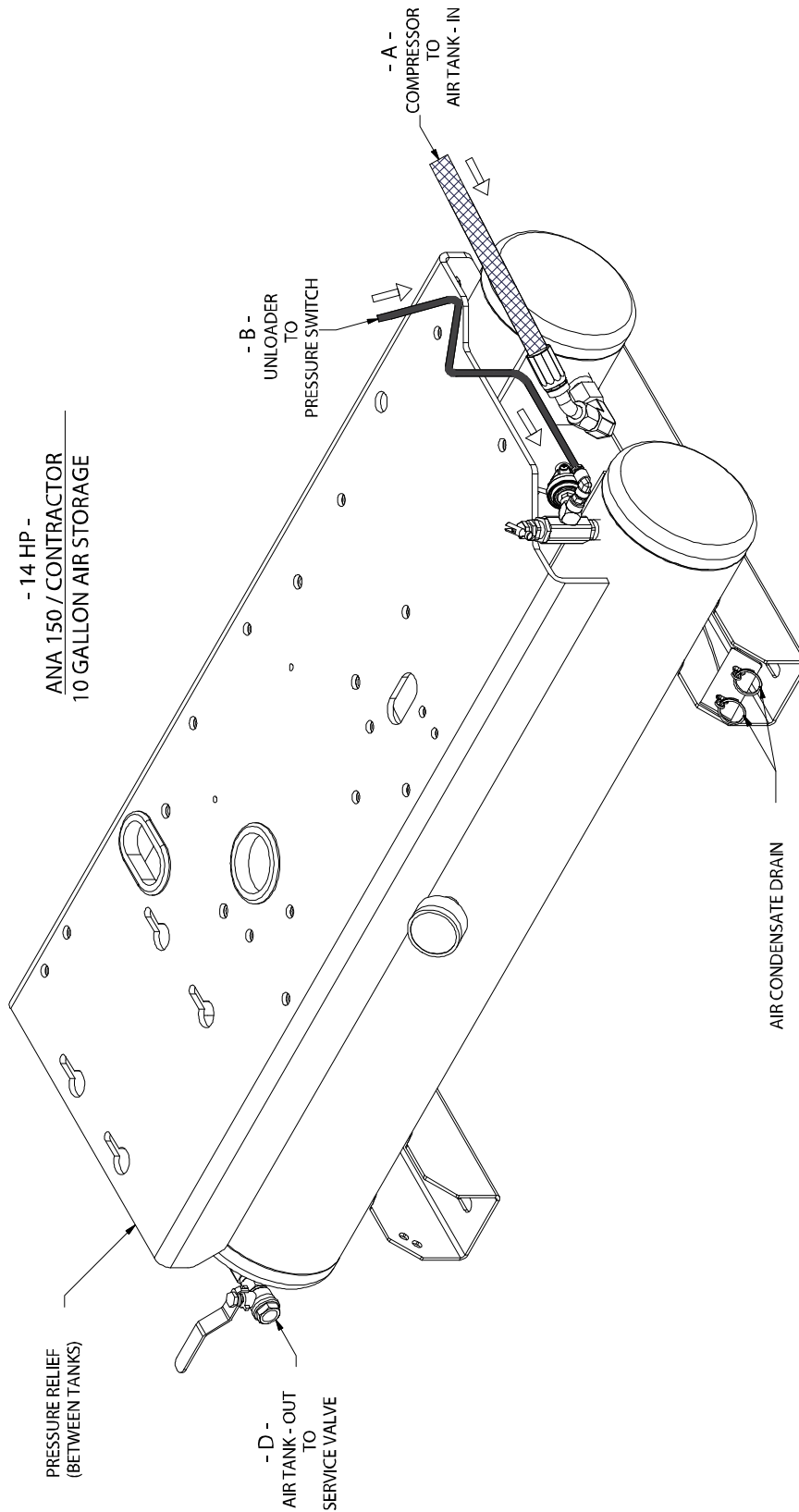

ID274888\_r0(2of4)

### 7.14 FLOW SCHEMATIC DIAGRAM (3 OF 4)

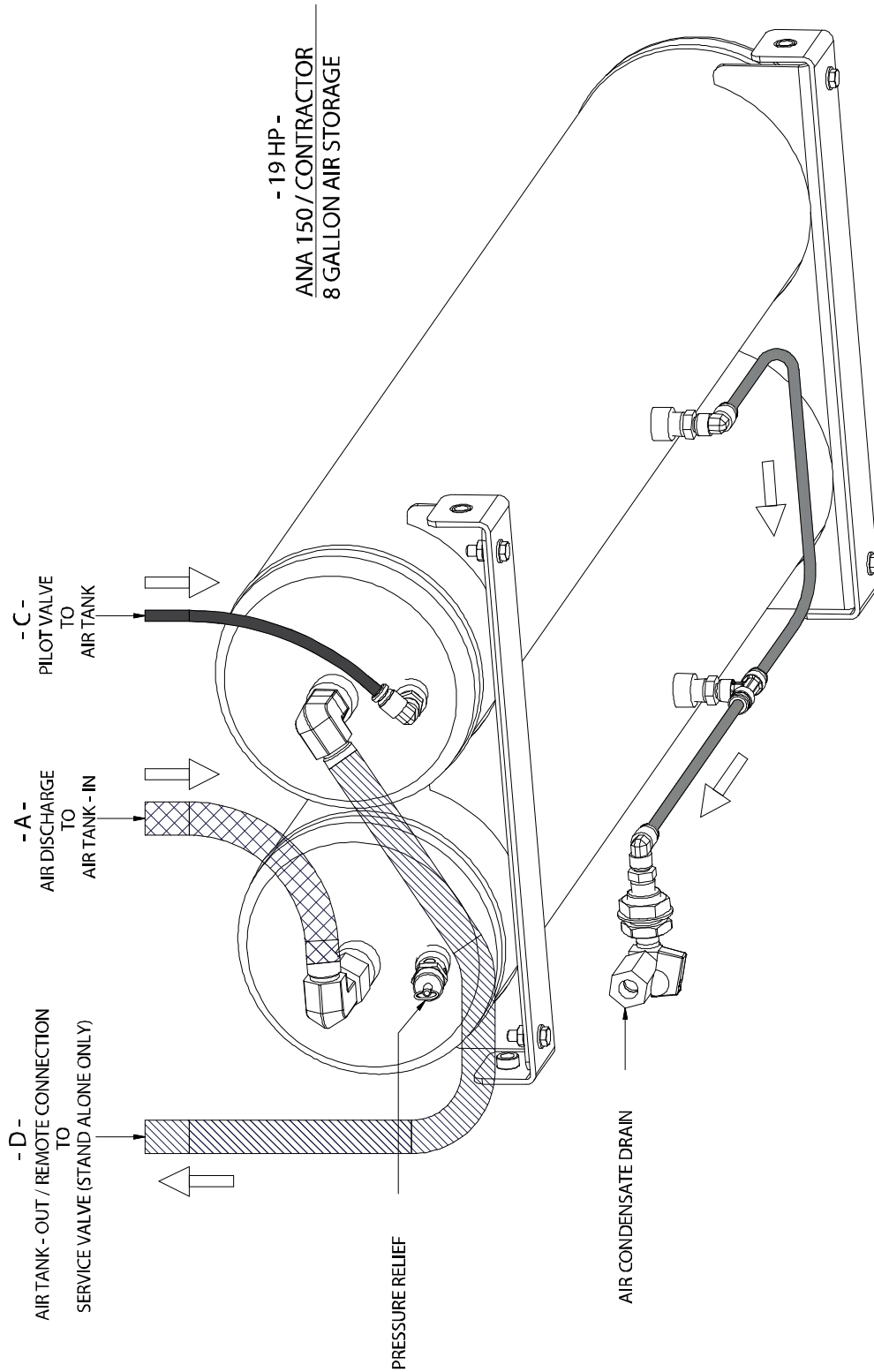

ID274888\_r0(3of4)

### 7.14 FLOW SCHEMATIC DIAGRAM (4 OF 4)

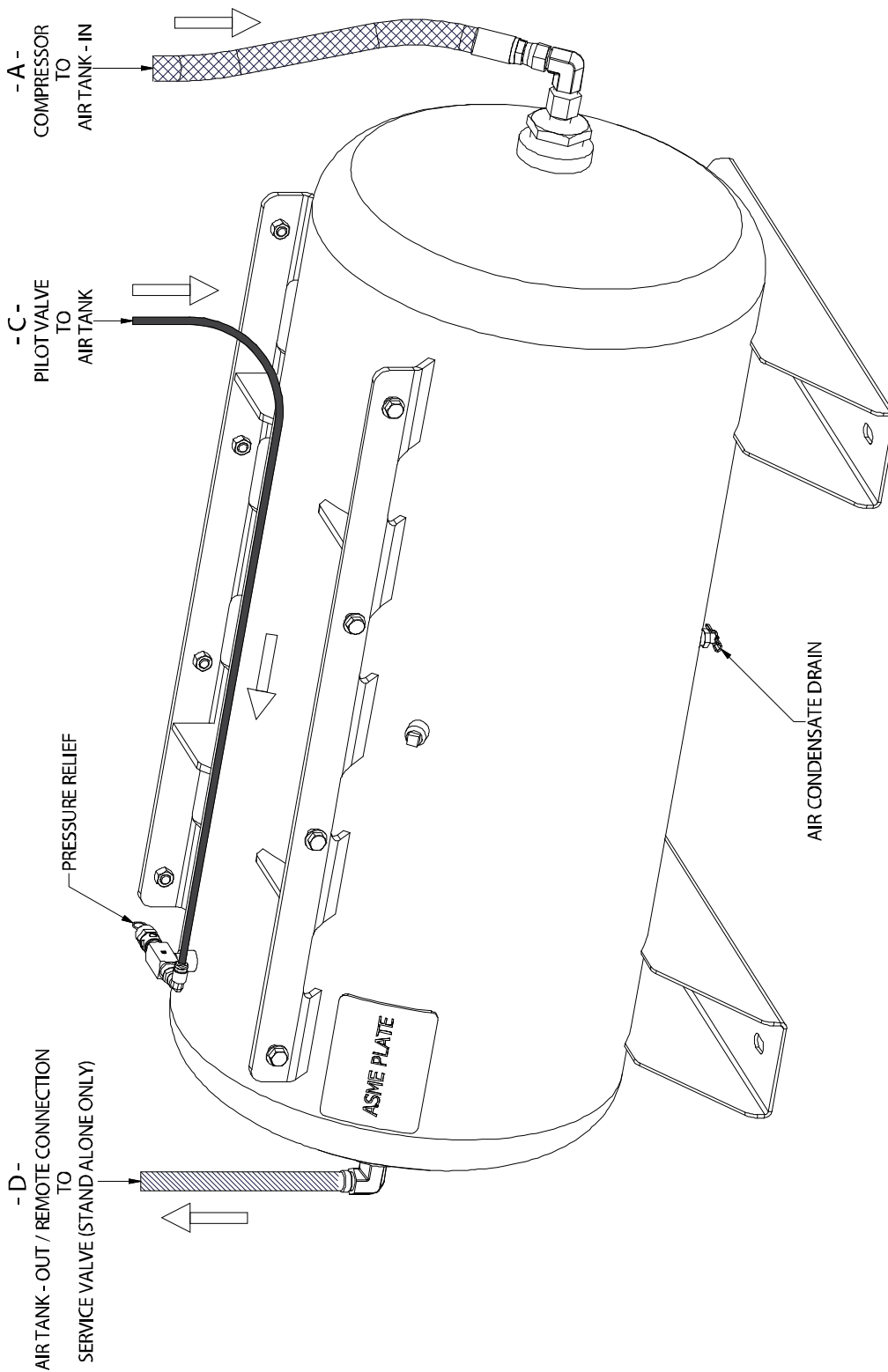

-19 & 14 HP -  
ANA 150 / CONTRACTOR  
30 GALLON AIR STORAGE

ID274888\_r0(4of4)

# 7.15A INSTALLATION AND DIMENSIONS - 8 GALLON TANK

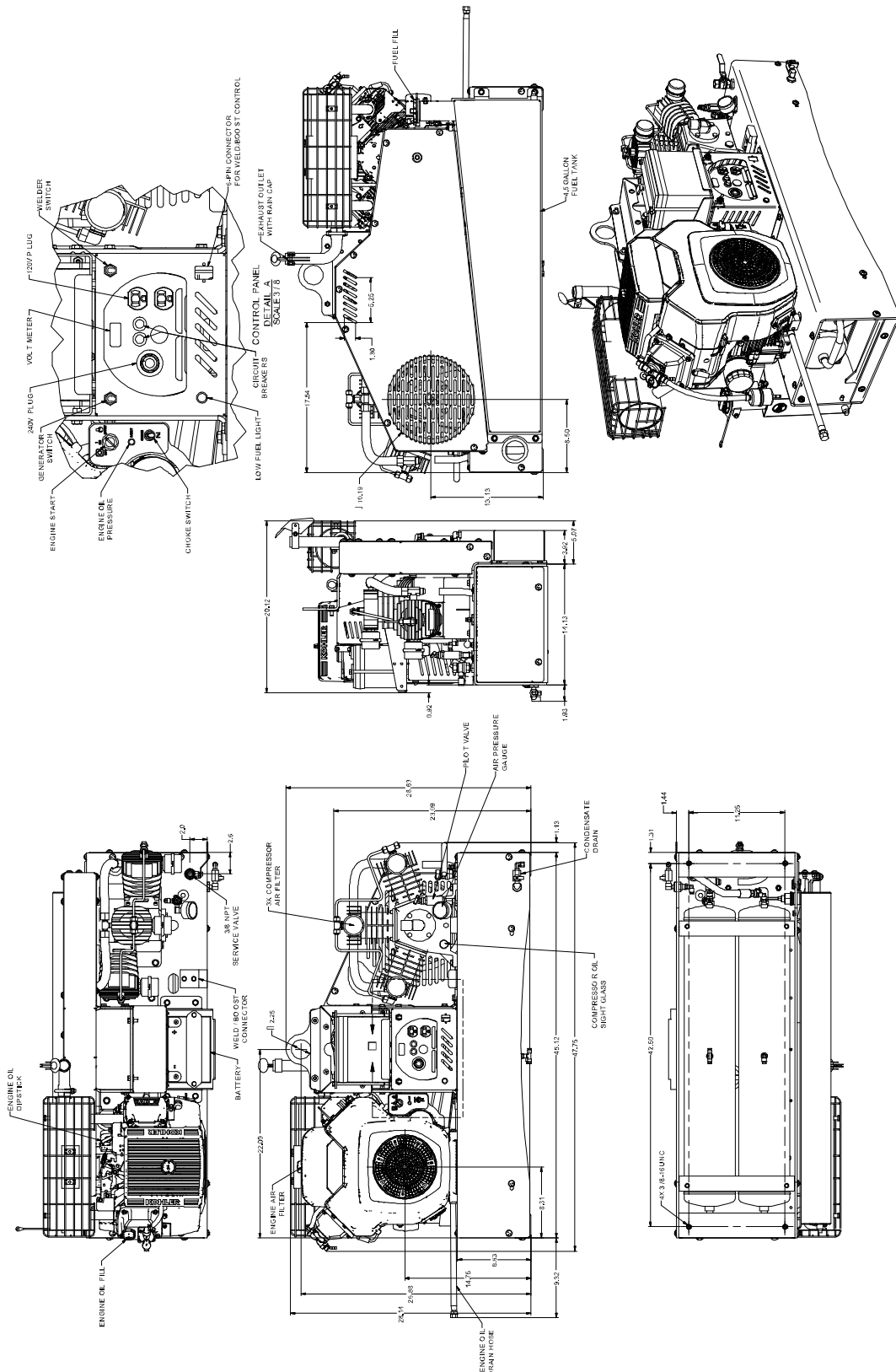

050666ID\_r1





## 7.16 HOSE INSTALLATION GUIDE

<p><b>wrong</b> <b>right</b></p> <p>1. Hose is weakened when installed in twisted position. Pressure in twisted hose tends to loosen fitting connections. Design so that machine motion produces bending rather than twisting.</p>	<p><b>wrong</b> <b>right</b></p> <p>2. Ample bend radius should be provided to avoid collapsing of line and</p>
<p><b>wrong</b> <b>right</b></p> <p>3. Exceeding minimum bend radius will greatly reduce hose assembly life.</p>	<p><b>wrong</b> <b>right</b></p> <p>4. Use elbows or other adapters as necessary to eliminate excess hose length and to insure neater installation for easier</p>
<p><b>wrong</b> <b>right</b></p> <p>5. When hose assembly is installed in a flexing application, remember that metal hose fittings are not part of the flexible portion. Allow ample free length for flexing.</p>	<p><b>wrong</b> <b>right</b></p> <p>6. When properly routing, use clamps to secure the hose in its proper position.</p>

**BLANK PAGE**





**VANAIR**®  
P O W E R T O G O™

**Vanair Manufacturing, Inc.**

**10896 West 300 North**

**Michigan City, IN 46360**

**Phone: (219) 879-5100**

**(800) 526-8817**

**Service: (844) VANSERV**

**[844-826-7378]**

**Service Fax: (219) 879-5335**

**Parts Fax: (219) 879-5340**

**Sales Fax: (219) 879-5800**

**[www.vanair.com](http://www.vanair.com)**

Printed in the U.S.A.

Specifications Subject to Change Without Prior  
Notice

050664-001	050670-001	050676-001
050665-001	050671-001	050677-001
050666-001	050672-001	050678-001
050667-001	050673-001	050679-001
050668-001	050674-001	050680-001
050669-001	050675-001	050681-001