

AIR N ARC[®]

BY VANAIR[®]

ALL-IN-ONE Power Systems[®]

AIR N ARC[®] 300 HYDRAULIC

ALL-IN-ONE POWER SYSTEMS[®] WELDER • GENERATOR • AIR COMPRESSOR • BATTERY BOOSTER OPERATION MANUAL & PARTS LIST

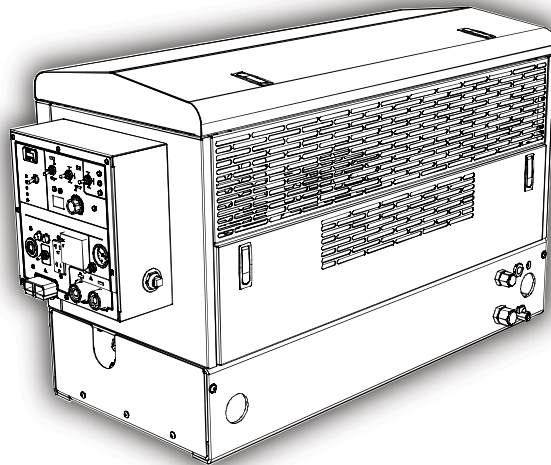

NOTE



Read this manual before installing, operating or servicing this equipment. Failure to comply with the operation and maintenance instructions in this manual WILL VOID THE EQUIPMENT WARRANTY.

NOTE

Making unauthorized modifications to the system components WILL VOID THE WARRANTY!

Always inform Vanair Manufacturing, Inc., before beginning any changes to the Air N Arc system.

Vanair Manufacturing, Inc.

10896 West 300 North
Michigan City, IN 46360

Phone: (219) 879-5100
(800) 526-8817

Service Fax: (219) 879-5335

Parts Fax: (219) 879-5340

Sales Fax: (219) 879-5800

www.vanair.com

NOTE

Use only Vanair Vanguard[™] Premium Synthetic Oil and Genuine Vanair Parts. Inspect and replace damaged components before operation. Substituting non-Vanguard[™] Oil or non-genuine Vanair filter components WILL VOID THE COMPRESSOR WARRANTY!



VANAIR[®]
AIR POWER TO GO[™]

090034-OP_r0

Effective Date:

03-2012

©2012 Vanair Manufacturing, Inc.

All rights reserved

**AIR N ARC®
ALL-IN-ONE POWER-SYSTEMS®**

RELIANT™ SERIES

POWERFLEX™ SERIES

PRO SERIES

CONTRACTOR SERIES

VIPER™ SERIES

FST™ SERIES

(844) VAN - SERV

SERVICE@VANAIR.COM

PARTS@VANAIR.COM

**10896 W. 300 N.
MICHIGAN CITY, IN 46360**

(800) 526-8817

VANAIR.COM

EFFECTIVE: JAN 8, 2016

090088_r1

VANAIR VANTAGE WARRANTY

This limited warranty supersedes all previous Vanair warranties and is exclusive with no other guarantees or warranties expressed or implied.

LIMITED WARRANTY—Subject to the expressed terms and conditions set forth below, Vanair Mfg., Inc. ("Vanair"), of Michigan City, Indiana (USA), warrants to the original retail purchaser of new Vanair equipment that such equipment is free from defects in materials and workmanship when shipped by Vanair.

For warranty claims received by Vanair within the applicable warranty periods described below, Vanair will repair or replace any warranted equipment, parts or components that fail due to defects in material or workmanship or refund the purchase price for the equipment, at Vanair's discretion. Vanair is not responsible for time or labor to gain access to the machine to perform work. **WARRANTY WILL BE VOID IF GENUINE VANAIR PARTS AND FLUIDS ARE NOT USED.**

Vanair must be notified in writing within thirty (30) days of any such defect or failure. No warranty work or returns without prior authorization is allowed. Vanair will provide instructions on the warranty claim procedures to be followed.

Warranty will commence upon receipt of the Warranty Registration Card. If the Warranty Registration Card is not received within six (6) months of shipment from Vanair, the warranty commencement date shall be thirty (30) days from the date of shipment from Vanair. Records of warranty adherence are the responsibility of the end user.

1. Lifetime Warranty Parts – 3 Years Labor
 - Rotary Screw Air Compressor Air End
2. 6 Years Parts – 3 Years Labor
 - Vanair Super Capacitor (VSC)
3. 3 Years Parts – 1 Year Labor
 - Reciprocating Compressor Air End
 - Generators
 - Welders
4. 2 Years Parts – 1 Year Labor
 - Hydraulic Motors
 - Hydraulic Pumps
5. 1 Year Parts – 1 Year Labor
 - All electronics including, but not limited to:
 - (i) I/O Boards
 - (ii) Modules
 - (iii) Panel Boxes
 - (iv) Instrumentation
 - (v) Clutches
 - (vi) Solenoids
 - (vii) Running Gear/Trailers
 - (viii) Compressor/Hydraulic Coolers, including Fan and Radiator Core

This Limited Warranty shall not apply to:

1. Consumable components, such as shaft seals, valves, belts, filters, capacitors, contactors, relays, brushes or parts that fail due to normal wear and use.
2. Items furnished by Vanair, but manufactured by others, such as engines and trade accessories (these items are covered by the manufacturer's warranty, if any).
3. Equipment that has been modified by any party other than Vanair or equipment which has not been used and maintained in accordance with Vanair's specifications.
4. Equipment which has been improperly installed and/or improperly operated, based upon Vanair's specifications for the equipment or industry standards.
5. Equipment installed by non-authorized or third party personnel.

Vanair products are intended for purchase and use by commercial/industrial users and persons trained and experienced in the use and maintenance of industrial equipment.

In the event of a warranty claim covered by this Limited Warranty, the exclusive remedies shall be, at Vanair's sole discretion: (i) repair; or (ii) replacement; (iii) where authorized in writing by Vanair in appropriate cases, the reasonable cost of repair or replacement at an authorized Vanair service facility; or (iv) payment of (or credit for) the purchase price (less reasonable depreciation based upon actual use) upon return of the equipment at the warranty claimant's risk and expense. Vanair will pay standard ground freight for any warranty item shipped to and from Vanair or (Vanair designated facility) within the first year of the applicable warranty period. Any additional expedited freight cost is the responsibility of the purchaser.

TO THE GREAT EXTENT PERMITTED BY APPLICABLE LAW, THE REMEDIES PROVIDED HEREIN ARE THE SOLE AND EXCLUSIVE REMEDIES APPLICABLE TO THE VANAIR EQUIPMENT. IN NO EVENT SHALL VANAIR BECOME LIABLE FOR DIRECT, INDIRECT, SPECIAL, PUNITIVE, INCIDENTAL OR CONSEQUENTIAL DAMAGES (INCLUDING LOSS OF PROFIT OR LOST BUSINESS OPPORTUNITY), WHETHER BASED ON CONTRACT, TORT OR ANY OTHER LEGAL THEORY. IN NO EVENT SHALL VANAIR BECOME OBLIGATED TO PAY MORE ON ANY WARRANTY CLAIM THAN THE PURCHASE PRICE ACTUALLY PAID BY THE ORIGINAL RETAIL PURCHASER.

THIS LIMITED WARRANTY IS MADE IN LIEU OF ALL OTHER WARRANTIES, EXPRESS OR IMPLIED, INCLUDING THE WARRANTIES OF MERCHANTABILITY AND/OR FITNESS FOR A PARTICULAR PURPOSE, OR ANY OTHER WARRANTY OR GUARANTY ARISING BY OPERATION OF LAW. ANY WARRANTY NOT EXPRESSLY PROVIDED HEREIN, IMPLIED WARRANTY, GUARANTY AND ANY REPRESENTATION REGARDING THE PERFORMANCE OF THE EQUIPMENT, AND ANY REMEDY FOR BREACH OF CONTRACT, IN TORT, OR ANY OTHER LEGAL THEORY WHICH, BUT FOR THIS PROVISION, MIGHT ARISE BY IMPLICATION, OPERATION OF LAW, CUSTOM OF TRADE, OR COURSE OF DEALING ARE EXCLUDED AND DISCLAIMED BY VANAIR.

Some states in the United States of America do not allow limitations of how long an implied warranty lasts, or the exclusion of incidental, indirect, special or consequential damages, and as such, the above limitations and exclusions may not apply to you. This warranty provides specific legal rights. Other rights may be available to you, but may vary from state to state.

In Canada, legislation in some provinces provides for certain additional warranties or remedies other than as stated herein, and to the extent that they may not be saved, the limitations and exclusions set out forth above may not apply. This Limited Warranty provides specific legal rights, and other rights may be available, but may vary from province to province.



VANAIR®
MOBILE POWER SOLUTIONS™

TABLE OF CONTENTS

WARRANTY BEHIND COVER

TABLE OF CONTENTS.....I

GLOSSARY.....IX

- G.1 GENERAL TERMS AND DEFINITIONS IX
- G.2 WELDING TERMS AND DEFINITIONS..... IX
- G.3 AIR COMPRESSOR TERMS AND DEFINITIONS X

WARRANTY CLAIMS PROCEDUREXIII

- CLAIMS PROCESS FOR WARRANTED PARTS XIII
- PROCEDURE XIII
- RETURN MATERIAL AUTHORIZATION FORM..... XVI

INTRODUCTION..... 1

- EXPERIENCE THE VANAIR ADVANTAGE 1
- A NOTE ON MANUAL LAYOUT NAVIGATION..... 1

SECTION 1: SAFETY3

- 1.1 GENERAL INFORMATION 3
- 1.2 DANGERS, WARNINGS, CAUTIONS, AND NOTES 3
- 1.3 INTERNATIONAL SAFETY SYMBOL 4
- 1.4 ARC WELDING HAZARDS..... 4
 - 1.4.1 ELECTRICAL SHOCK CAN KILL..... 4
 - 1.4.2 FUMES AND GASSES CAN BE HAZARDSOUS 6
 - 1.4.3 BUILD UP OF GAS CAN INJURE OR KILL 6
 - 1.4.4 ENCLOSED SPACES CAN CAUSE A BUILD-UP OF NOXIOUS FUMES AND OVERHEATING..... 7
 - 1.4.5 ARC RAYS CAN BURN EYES AND SKIN 7
 - 1.4.6 WELDING CAN CAUSE FIRE AND EXPLOSION 7
 - 1.4.7 FLYING METAL CAN INJURE EYES 8
 - 1.4.8 HOT PARTS CAN CAUSE SEVERE BURNS 9
 - 1.4.9 NOISE CAN DAMAGE HEARING..... 9
 - 1.4.10 MAGNETIC FIELDS CAN AFFECT PACEMAKERS..... 9

Continued on next page...

SECTION 1: SAFETY (CONTINUED)

- 1.4.11 CYLINDERS CAN EXPLODE IF DAMAGED..... 9
- 1.5 HYDRAULIC SAFETY 10
 - 1.5.1 AVOID HIGH PRESSURE FLUIDS..... 10
 - 1.5.2 MOVING PARTS CAN CAUSE INJURY..... 10
 - 1.5.3 HOT PARTS CAN CAUSE SEVERE BURNS..... 11
 - 1.5.4 ENCLOSED SPACES CAN CAUSE A BUILD-UP OF NOXIOUS FUMES AND OVERHEATING..... 11
- 1.6 COMPRESSED AIR HAZARDS 11
 - 1.6.1 BREATHING COMPRESSED AIR CAN CAUSE SERIOUS INJURY OR DEATH..... 11
 - 1.6.2 ENCLOSED SPACES CAN CAUSE A BUILD-UP OF NOXIOUS FUMES AND OVERHEATING..... 12
 - 1.6.3 COMPRESSED AIR CAN CAUSE INJURY..... 12
 - 1.6.4 TRAPPED AIR PRESSURE AND WHIPPING HOSES CAN CAUSE INJURY..... 12
 - 1.6.5 HOT METAL FROM AIR ARC CUTTING AND GOUGING CAN CAUSE FIRE OR EXPLOSION..... 12
 - 1.6.6 HOT PARTS CAN CAUSE SEVERE BURNS..... 12
 - 1.6.7 READ INSTRUCTIONS..... 13
- 1.7 ADDITIONAL SYMBOLS FOR INSTALLATION, OPERATION AND MAINTENANCE..... 13
 - 1.7.1 FALLING UNIT CAN CAUSE INJURY..... 13
 - 1.7.2 OVERHEATING CAN DAMAGE MOTORS..... 13
 - 1.7.3 FLYING SPARKS CAN CAUSE INJURY..... 13
 - 1.7.4 OVERUSE CAN CAUSE OVERHEATING..... 14
 - 1.7.5 ENCLOSED SPACES CAN CAUSE A BUILD-UP OF NOXIOUS FUMES AND OVERHEATING..... 14
 - 1.7.6 TILTING OF TRAILER CAN CAUSE INJURY..... 14
 - 1.7.7 READ INSTRUCTIONS..... 14
 - 1.7.8 H.F. RADIATION CAN CAUSE INTERFERENCE..... 14
 - 1.7.9 ARC WELDING CAN CAUSE INTERFERENCE..... 15
- 1.8. CALIFORNIA PROPOSITION 65 WARNINGS..... 15
- 1.9 PRINCIPAL SAFETY STANDARDS 16
- 1.10 EMF INFORMATION 17
- 1.11 MACHINE CANOPY ACCESS SAFETY SWITCHES 18
- 1.12 DISPOSING OF MACHINE FLUIDS..... 18

SECTION 2: DESCRIPTION 20

- FIGURE 2-1: MAJOR MACHINE COMPONENTS LOCATIONS 20
- 2.1 GENERAL DESCRIPTION 21

Continued on next page...

SECTION 2: DESCRIPTION (CONTINUED)

2.2	COMPRESSED AIR SYSTEM	21
2.2.1	COMPRESSOR UNIT	21
2.2.2	ELECTRONIC INLET VALVE	22
2.2.3	AIR INLET FILTER	23
2.2.4	SECONDARY SPIN-ON AIR/OIL COALESCER.....	23
2.2.5	MINIMUM PRESSURE/CHECK VALVE	23
2.2.6	PRESSURE RELIEF VALVE	23
2.2.7	ADJUSTABLE PRESSURE SWITCH.....	24
2.2.8	OIL RESERVOIR AND PRIMARY AIR/OIL SEPARATOR.....	24
2.3	OIL COOLING SYSTEM	24
2.3.1	COMPRESSOR TEMPERATURE AND PRESSURE SWITCHES	26
2.3.2	COMPRESSOR SPIN-ON OIL FILTER.....	26
2.4	MOTOR	26
2.5	AC GENERATOR	26
2.6	INSTRUMENTATION	27
2.6.1	VOLTS/AMPS METER	28
2.6.2	WELDER FUNCTION SWITCHES.....	28
2.6.3	DC CHARGER MODE TOGGLE SWITCH.....	28
2.6.4	VOLTS/AMPS MANUAL ADJUSTMENT DIAL.....	28
2.6.5	COMPRESSOR AIR PRESSURE GAUGE.....	29
2.6.6	COMPRESSOR ON/OFF TOGGLE SWITCH.....	29
2.6.7	WELDER LEAD JUNCTION.....	29
2.6.8	HZ/VOLTAGE METER.....	29
2.6.9	BATTERY CABLE RECEPTACLE	29
2.6.10	GENERATOR CONTROL ON/OFF TOGGLE SWITCH.....	31
2.6.11	AC VOLTAGE OUTLETS.....	31
2.6.12	CIRCUIT BREAKER OVERLOAD TRIP/RESET BUTTONS.....	31
2.6.13	FRONT ACCESS PANEL OPEN INDICATOR LAMP.....	31
2.6.14	COMPRESSOR OVER PRESSURE INDICATOR LAMP.....	31
2.6.15	COMPRESSOR OVERTEMP INDICATOR LAMP	31
2.6.16	HYDRAULIC OVERTEMP INDICATOR LAMP.....	32
2.6.17	MACHINE CONTROL (RESET) SWITCH.....	32

Continued on next page...

SECTION 2: DESCRIPTION (CONTINUED)

2.6.18 HOUR METER32

SECTION 3: SPECIFICATIONS..... 33

TABLE 3A: SPECIFICATIONS - WELDER AND GENERATOR..... 33

TABLE 3B: SPECIFICATIONS - MOTOR..... 33

TABLE 3C: SPECIFICATIONS — AIR COMPRESSOR 33

TABLE 3D: SPECIFICATIONS — UNIT WEIGHT AND DIMENSIONS 34

TABLE 3E: BOLT AND TORQUE SPECIFICATIONS 34

TABLE 3F: VARIOUS FUNCTION FACTORY SETTING RANGES 35

TABLE 3G: GENUINE VANGUARD™ OIL CHARACTERISTICS 35

TABLE 3H: MACHINE PACKAGE DIMENSIONS 35

SECTION 4: INSTALLATION 37

4.1 MACHINE PACKAGE RECEIPT/INSPECTION 37

4.2 ANA 300 SERIES ALL-IN-ONE MACHINE PACKAGE PREPARATION..... 38

4.3 GENERAL OVERVIEW OF INSTALLATION 38

4.4 PREPARING THE VEHICLE SERVICE BODY 38

 4.4.1 MACHINE CLEARANCE ALLOWANCE..... 40

 4.4.2 DETERMINING PROPER VENTILATION REQUIREMENTS..... 40

 4.4.3 ROOF REQUIREMENTS (IF APPLICABLE)..... 40

4.5 MOUNTING THE MACHINE..... 42

 4.5.1 SEPARATING THE MACHINE FROM THE CRATE MOUNTING..... 43

 4.5.2 MARKING THE MACHINE MOUNTING LOCATION 43

 4.5.3 STABILIZING PRECAUTIONS FOR MACHINE MOUNTING 44

4.6 GROUNDING THE MACHINE..... 45

4.7 INSTALLING THE CONTROL TRUNK LINE..... 45

4.8 INSTALLING THE (OPTIONAL) REMOTE CONTROL PANEL..... 45

4.9 INSTALLING THE REMOTE AIR TANK 45

4.10 POST-SET UP INITIAL TEST FUNCTION 46

4.11 COMPRESSOR FLOW SCHEMATIC DIAGRAM..... 48

4.12 INSTALLATION AND DIMENSIONS DIAGRAM (PART 1 OF 2) 49

4.12 INSTALLATION AND DIMENSIONS DIAGRAM (PART 2 OF 2) 50

SECTION 5: OPERATION 53

5.1 GENERAL INFORMATION 53

5.2 MACHINE START-UP AND SHUTDOWN PROCEDURE..... 54

Continued on next page...

SECTION 5: OPERATION (CONTINUED)

5.2.1	MACHINE START-UP	54
5.2.2	MACHINE SHUTDOWN.....	55
5.3	MOTOR THROTTLE CONTROL FUNCTIONS.....	56
5.4	OPERATING THE WELDER.....	56
5.4.1	WELDER OPERATING PROCEDURE.....	57
5.4.1.1	CC (CONSTANT CURRENT) MODE.....	57
5.4.1.2	CV (CONSTANT VOLTAGE) MODE - USING A VOLTAGE SENSING SUITCASE FEEDER	59
5.4.1.3	CV (CONSTANT VOLTAGE) MODE - USING A SPOOL GUN.....	59
5.5	OPERATING THE GENERATOR	60
5.6	OPERATING THE AIR COMPRESSOR.....	61
5.7	OPERATING THE BATTERY BOOSTER/CHARGER.....	62
5.7.1	CONNECTION - DISCONNECTION SEQUENCE AND OPERATION.....	62
5.8	EXTREME CONDITION OPERATION.....	63
5.8.1	COLD WEATHER OPERATION.....	64
5.8.1.1	GENERAL OPERATION	64
5.8.1.2	MACHINE OPERATION.....	64
5.8.2	HIGH TEMPERATURE OPERATION.....	64
5.8.2.1	MACHINE OPERATION.....	64
5.8.3	HIGH DUST CONTENT OPERATION.....	65
5.8.3.1	MACHINE OPERATION.....	65
5.8.4	HIGH ALTITUDE OPERATION.....	65

SECTION 6: MAINTENANCE 67

6.1	GENERAL INFORMATION	67
6.2	ROUTINE MAINTENANCE SCHEDULE	67
6.3	MAINTENANCE SCHEDULE TABLE	69
6.4	REPLACEMENT PARTS.....	72
6.5	MAINTENANCE ACCESS	72
6.6	PARTS REPLACEMENT AND ADJUSTMENT PROCEDURES	73
6.6.1	COMPRESSOR AIR FILTER.....	74
6.6.1.1	COMPRESSOR AIR FILTER CHECK	74

Continued on next page...

SECTION 6: MAINTENANCE (CONTINUED)

- 6.6.1.2 COMPRESSOR AIR FILTER INSPECTION 75
- 6.6.1.3 COMPRESSOR AIR FILTER REPLACEMENT 75
- 6.6.2 REPAIRING THE AIR INLET VALVE.....76
- 6.6.3 CHECKING THE COMPRESSOR OIL 78
- 6.6.4 REPLACING THE COMPRESSOR OIL FILTER ELEMENT 79
- 6.6.5 CHANGING THE COMPRESSOR OIL 80
- 6.6.6 REPLACING THE SPIN-ON AIR/OIL COALESCER 81
- 6.6.7 REPAIRING THE COMPRESSOR SHAFT SEAL 82
 - 6.6.7.1 PART I - REMOVING THE COMPRESSOR SERPENTINE BELT 82
 - 6.6.7.2 PART II - ACCESSING THE COMPRESSOR UNIT SHAFT SEAL 84
 - 6.6.7.3 PART III - REPLACING THE COMPRESSOR SERPENTINE BELT 85
- 6.6.8 REPLACING THE AIR INLET SOLENOID VALVE 85
 - 6.6.8.1 SOLENOID VALVE - PREPARATION BEFORE MOUNTING 87
 - 6.6.8.2 CONNECTING THE NEW SOLENOID VALVE 87
- 6.6.9 DRAINING THE AIR TANK.....88
- 6.6.10 REBUILDING THE MINIMUM PRESSURE/CHECK VALVE 90
 - 6.6.10.1 SETTING THE MINIMUM PRESSURE VALVE 90
- 6.6.11 INSPECTING THE SYSTEM COOLERS 91
- 6.6.12 ADJUSTING THE MOTOR SPEED 92
- 6.6.13 ADJUSTING THE PRESSURE SETTING 92
- 6.6.14 REPLACING AND RE-TENSIONING THE SERPENTINE DRIVE BELTS..... 94
 - 6.6.14.1 RE-TENSIONING THE AIR COMPRESSOR SERPENTINE DRIVE BELT 94
 - 6.6.14.2 REPLACING THE AIR COMPRESSOR SERPENTINE DRIVE BELT 95
 - 6.6.14.3 RE-TENSIONING THE GENERATOR SERPENTINE BELT 96
 - 6.6.14.4 REPLACING THE GENERATOR SERPENTINE DRIVE BELT 97
- 6.7 SERVICING THE SYSTEM FUSES AND CIRCUIT BREAKERS 99
- 6.8 STORAGE AND INTERMITTENT USE 99
 - 6.8.1 INTERMITTENT USE..... 99
 - 6.8.2 LONG TERM STORAGE 99

SECTION 7: TROUBLESHOOTING 101

- 7.1. GENERAL INFORMATION 101
- 7.2 TROUBLESHOOTING GUIDE 102

Continued on next page...

SECTION 8: DIAGRAMS 109

8.1	GENERAL INFORMATION	109
8.2	WIRING DIAGRAM - AIR N ARC 300 SERIES (HYDRAULIC)	110
8.3	COMPRESSOR FLOW SCHEMATIC DIAGRAM	111

SECTION 9: ILLUSTRATED PARTS LIST 113

9.1	PARTS ORDERING PROCEDURE	113
	TABLE 9A: RECOMMENDED SPARE PARTS LIST	114
9.2	AIR N ARC 300 SYSTEMS ASSEMBLIES	116
9.3	COMPRESSOR AND PARTS ASSEMBLY (1 OF 2)	118
9.3	COMPRESSOR AND PARTS ASSEMBLY (2 OF 2)	120
9.4	COOLING SYSTEM	122
9.5	COOLING SYSTEM - COMPRESSOR	124
9.6	FRAME AND CANOPY	126
9.7	INSTRUMENT PANEL (1 OF 2)	128
9.7	INSTRUMENT PANEL (2 OF 2)	130
9.8	GENERATORS AND PARTS	132
9.9	MOTOR ASSEMBLY	134
9.10	AIR STORAGE TANK	136
9.11	ASSEMBLY FLOW CONTROL (1 OF 2)	138
9.11	ASSEMBLY FLOW CONTROL (2 OF 2)	140
9.12	DECAL LOCATIONS (1 OF 3)	142
9.12	DECAL LOCATIONS (2 OF 3)	144
9.12	DECAL LOCATIONS (3 OF 3)	146

APPENDIX A: ADDITIONAL INFORMATION 149

A.1	ELECTRIC MOTOR CHART - STARTING WATTS	149
A.2	EXTENSION CORD CHART	150
A.3	WATTAGE REQUIREMENTS FOR COMMON RECEPTACLE UNITS	151
A.4	AIR TOOL AIR CONSUMPTION CHART	152
A.5	AIR N ARC 300 SERIES ALL-IN-ONE POWER SYSTEM AVAILABLE OPTIONS LIST	153
A.6	HOSE INSTALLATION GUIDE	155

APPENDIX B: MAINTENANCE AND SERVICE LOG 157

B.1	GENERAL DESCRIPTION	157
B.2	MAINTENANCE AND SERVICE LOG	158

BLANK PAGE

GLOSSARY: TERMS AND DEFINITIONS

G.1 GENERAL TERMS AND DEFINITIONS

Air/Oil Separator - Coalescer element.

CFM - Cubic Feet per Minute.

ft-lb - Foot Pound (torque measurement).

N.C. - Normally closed.

N.O. - Normally open.

RMA - Return Material Authorization (number). This number is assigned by a service or warranty technician, and is needed for warranty claims.

RPM - Revolutions Per Minute.

Speed Control - Governor.

G.2 WELDING TERMS AND DEFINITIONS

Air Carbon Arc Cutting (CAC-A) - A cutting process by which metals are melted by the heat of an arc using a carbon electrode. Molten metal is forced away from the cut by a blast of forced air.

Alternating Current (AC) - An electrical current that reverses its direction at regular intervals, such as 60 cycles alternating current (AC), or 60 hertz.

Amperage - The measurement of the amount of electricity flowing past a given point in a conductor per second. Current is another name for amperage.

Arc - The physical gap between the end of the electrode and the base metal. The physical gap causes heat due to resistance of current flow and arc rays.

Constant Current (CC) Welding Machine - These welding machines have limited maximum short circuit current, with consistent amperage regardless of the voltage output.

Constant Voltage (CV) Welding Machine - This type of welding machine output maintains a relatively stable, consistent voltage regardless of the amperage output. It results in a relatively flat volt-amp curve.

Current - Another name for amperage. The amount of electricity flowing past a point in a conductor every second.

Direct Current (DC) - Flows in one direction and does not reverse its direction of flow as alternating current does.

Direct Current Electrode Negative (DCEN) - The direction of current flow through a welding circuit when the electrode lead is connected to the negative terminal and the work lead is connected to the positive terminal of a DC welding machine. Also called direct current, straight polarity (DCSP).

Direct Current Electrode Positive (DCEP) - The direction of current flow through a welding circuit when the electrode lead is connected to a positive terminal and the work lead is connected to a negative terminal to a DC welding machine. Also called direct current, reverse polarity (DCRP).

Duty Cycle - The number of minutes out of a 10-minute time period an arc welding machine can be operated at maximum rated output. An example would be 60% duty cycle at 250 amps. This would mean that at 250 amps the welding machine can be used for 6

minutes and then must be allowed to cool with the fan motor running for 4 minutes.

Flux Cored Arc Welding (FCAW) - An arc welding process which melts and joins metals by heating them with an arc between a continuous, consumable electrode wire and the work. Shielding is obtained from a flux contained within the electrode core. Added shielding may or may not be provided from externally supplied gas or gas mixture.

Hertz - Hertz is often referred to as "cycles per second". In the United States, the frequency or directional change of alternating current is usually 60 hertz.

KVA (Kilovolt-amperes) - Kilovolt-amperes. The total volts times amps divided by 1,000, demanded by a welding power source from the primary power furnished by the utility company.

KW (Kilowatts) - Primary KW is the actual power used by the power source when it is producing its rated output. Secondary KW is the actual power output of the welding power source. Kilowatts are found by multiplying volts and amps and dividing by 1,000 and taking into account any power factor.

Microprocessor - One or more integrated circuits that can be programmed with stored instructions to perform a variety of functions.

MIG Welding (GMAW or Gas Metal Arc Welding) - Also referred to as solid wire welding. An arc welding process which joins metals by heating them with an arc. The arc is between a continuously fed filler metal (consumable) electrode and the work piece. Externally supplied gas or gas mixtures provide shielding.

Open-Circuit Voltage (OCV) - As the name implies, no current is flowing in the circuit because the circuit is open. The voltage is impressed upon the circuit, however, so that when the circuit is completed, the current will flow immediately.

Plasma Arc Cutting - An arc cutting process which severs metal by using a constricted arc to melt a small area of the

work. This process can cut all metals that conduct electricity.

Pounds Per Square Inch (psi) - A measurement equal to a mass or weight applied to one square inch of surface area.

Rated Load - The amperage and voltage the power source is designed to produce for a given specific duty cycle period. For example, 275 amps, 25 load volts, at 60% duty cycle.

Stick Welding (SMAW or Shielded Metal Arc) - An arc welding process which melts and joins metals by heating them with an arc, between a covered metal electrode and the work. Shielding gas is obtained from the electrode outer coating, often called flux. Filler metal is primarily obtained from the electrode core.

TIG Welding (GTAW or Gas Tungsten Arc) - Often called TIG welding (Tungsten Inert Gas), this welding process joins metals by heating them with a tungsten electrode which should not become part of the completed weld. Filler metal is sometimes used and argon inert gas or inert gas mixtures are used for shielding.

Voltage - The pressure or force that pushes the electrons through a conductor. Voltage does not flow, but causes amperage or current to flow. Voltage is sometimes termed electromotive force (EMF) or difference in potential.

Voltage-Sensing Wire Feeder - Feeder operates from arc voltage generated by welding power source.

Wire Feed Speed - Expressed in in/min or mm/s, and refers to the speed and amount of filler metal fed into a weld. Generally speaking the higher the wire feed speed, the higher the amperage.

G.3 AIR COMPRESSOR TERMS AND DEFINITIONS

Aftercoolers - devices for removing the heat of compression of the air or gas after

compression is completed. They are one of the most effective means of removing moisture from compressed air.

Air Receivers - tanks into which the compressed air is discharged from the air compressor. Receivers help to eliminate pulsations in the discharge line and also act as storage capacity during intervals when the demand increases.

Check Valve - Ensures the air flows in one direction.

Discharge Pressure - This is the absolute pressure of the air at outlet (delivery) of a compressor.

Free Air Delivery (FAD) - Free air delivery is the volume of air delivered under the conditions of temperature and pressure existing at the compressor intake. This is generally taken as 1.0332 kg/cm square abs & 15 degree Centigrade.

Inlet Pressure - This is the absolute pressure of the air at inlet (suction) to a compressor.

Line Pressure Gauge - Reads amount of pressure in the air hose, which supplies the tool with air.

PSIG - pounds per square inch gauge

Rotary Air Compressors - those which utilize two inter-meshing helical rotors to trap a volume of air, then compress it to a higher pressure.

Single Stage Air Compressors - those in which compression from initial to final pressure is complete in a single step or stage.

Tank - Holds the compressed air until used by an air tool or for some other purpose.

Tank Pressure Gauge - Indicates amount of pressure in tank.

BLANK PAGE

WARRANTY CLAIMS PROCEDURE

CLAIMS PROCESS FOR WARRANTED VANAIR PARTS

This process must be used by owners of Vanair® equipment in situations where a warranted item needs repair or replacement under the terms of the purchase warranty. Do not return items to Vanair without prior authorization from the Vanair Warranty Administrator.

PROCEDURE:

When a customer needs assistance in troubleshooting a system and/or returning parts, follow the steps below.

1. Locate the machine's serial number:

The machine package serial number plate is located inside the machine compartment on the floor near to the generator mounting location (see *Figure W-1*).

The compressor also has an individual serial number (see *Figure W-2*). For particular compressor unit issues, the compressor serial number may be needed. In any case, motor and/or compressor issues can be confirmed using the machine serial number as found in *Figure W-1*.

2. Fill out the Return Material Authorization (RMA) Form's required information:

Locate the form on **page XVI** of this Section. Follow the instructions given on the form to fill in the information needed. This form is used for the purpose of soliciting a warranty case. All of the field information **except** for the bottom section block fields, which include *Disposition of Goods*, *Notifications* and *Additional Notes*, will be required.

3. Have a list of the symptoms/condition/malfunctions along with any applicable temperature and pressure readings, and also the number of operational hours available:

The above information is needed in addition to the information from **Step #2**.

NOTE

The RMA number must be placed on the outside of the package being returned.

NOTE

All labor claims or invoices must be approved by the Vanair Warranty Administrator prior to starting repair work along with the cost of the repair. All paper work associated with the returned item and warranty repair cost must reference the RMA number issued against the part, and be forwarded to Vanair within 30 days of the completion of work.

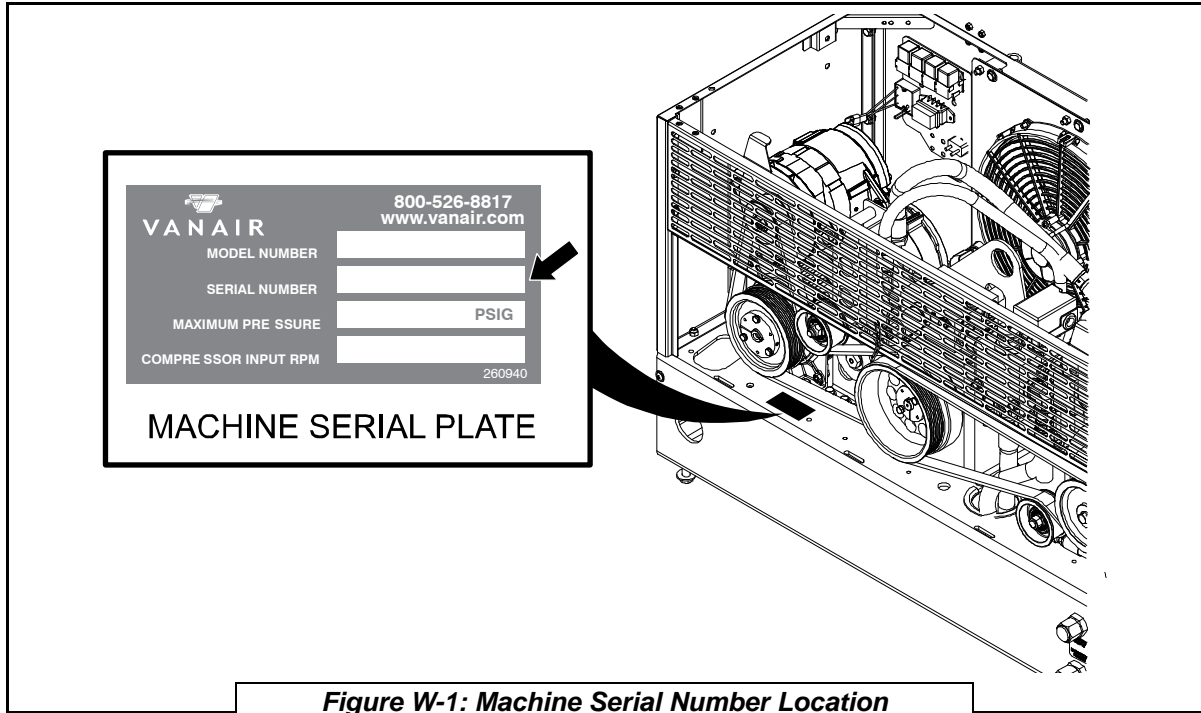
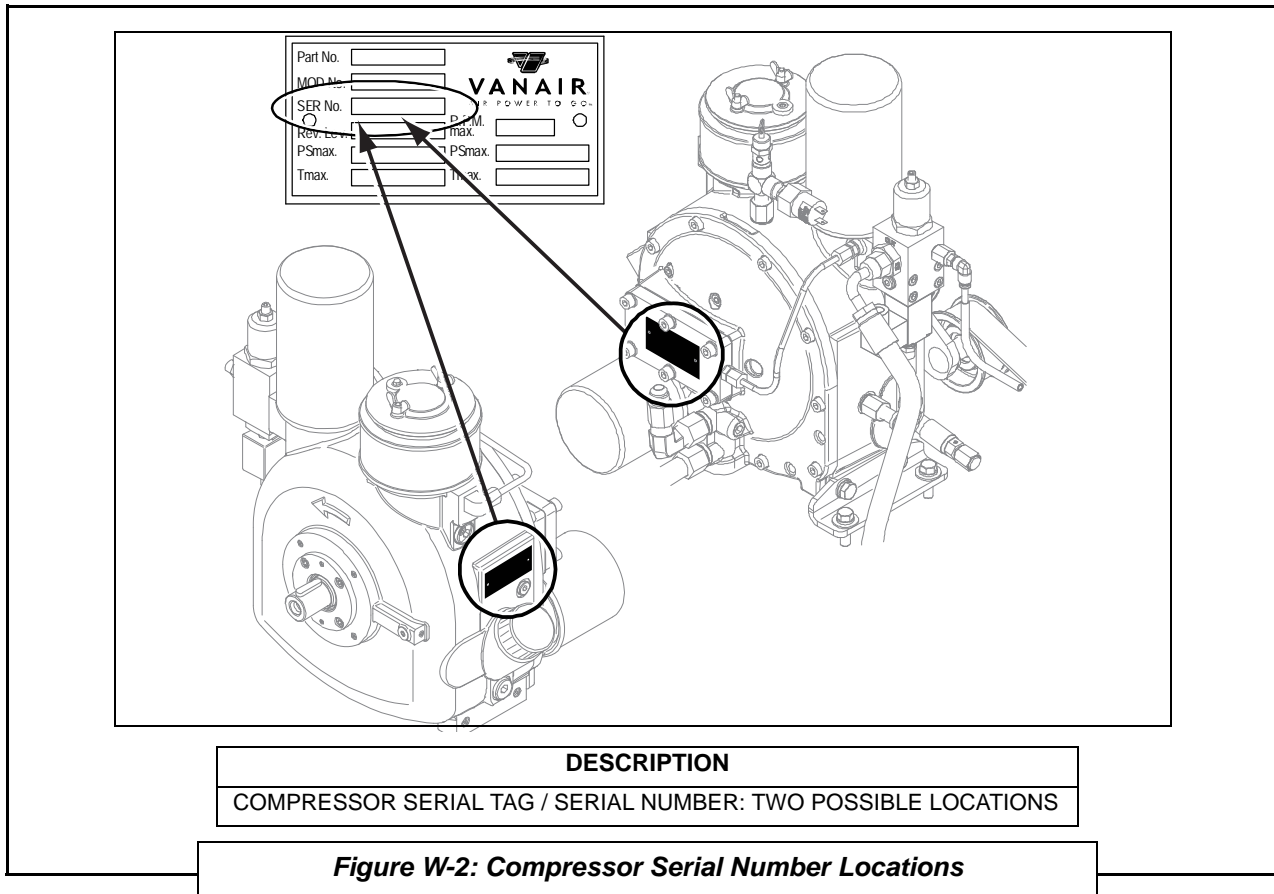

Figure W-1: Machine Serial Number Location



4. **Contact the Vanair® Service Department by phone (1-219-879-5100, ext. 400) to speak with a Service Technician.**
5. **Vanair Service will troubleshoot the problem based on the information provided by the customer, and attempt to return the unit to service as quickly as possible.**
6. **If the unit cannot be returned to service, and Vanair determines this matter is a warranty issue, the Service Technician will assign an RMA (Return Material Authorization) number that will provide for the return of the item to Vanair for analysis and a final determination as to the item's warranty status.**

Customers have 30 days after the RMA number is issued to return the item. If the part is not returned within this period, the RMA is void and any claims will be denied.

Before sending a warranty part to a customer, Vanair® will need a P.O. or credit card number to cover the cost of the part and shipping. After the part is analyzed and deemed to be covered under warranty, Vanair will issue credit to the customer. All parts eligible for warranty must have the RMA number on the invoice at the time of purchase.

No items can be returned "freight collect". Freight costs will be addressed at the time the claim is closed. The customer pays any additional costs for warranty parts delivered through expedited services (i.e., Next Day, Second Day).

VANAIR WILL NEVER ACCEPT ANY INVOICES FOR PARTS RETURNED: ANY PARTS RETURNED VIA INVOICE WILL BE RETURNED FREIGHT COLLECT: NO PARTS ARE TO BE RETURNED FREIGHT COLLECT!

Vanair Mfg., Inc. strives to continuously improve its customer service. Please forward any questions, comments, or suggestions to Vanair Service (219-879-5100) or e-mail us (service@vanair.com).

RETURN MATERIAL AUTHORIZATION FORM



Ph. 219-879-5100
 Fax. 219-879-5335
 service@vanair.com

Return Material Authorization

10896 W. 300 N.
 Michigan City, IN 46360

S / N: 30 _____	Customer: _____	Date: _____
AnA S/N: _____	RMA#: _____	Contact: _____
Email: _____	Phone: _____	
Fax: _____	Address: _____	
Tech: _____	Dealer: _____	PO#: _____

GENERAL INFORMATION

All returns are sent back for warranty consideration and are subject to factory inspection and analysis. Vanair® is not responsible for shipping damage due to insufficient or improper packaging methods. Failure to identify returned goods with the assigned RMA number on the outside of the shipping package will delay processing or result in the shipment being returned, freight collect. To receive warranty parts, a credit card or Purchase Order must be given to the service technician. Once the disposition of the part is determined, (I.E. manufacturing defect or other) Vanair will credit your account if covered by warranty. You can also contact the Service Department by email at service@vanair.com if you have any questions.

Return parts to the address listed above.

INSTRUCTIONS TO CUSTOMERS

- 1 Product must be returned within 30 days from the day the RMA is issued. The RMA is void thereafter and any parts received after this time frame will be returned freight collect or not accepted.
- 2 The RMA number must be placed on the outside of the shipping package. Do not write the RMA number on the component with permanent marker, this damages the component. Please use a tag.
- 3 Components (including generators) must be returned completely assembled with no loose parts or they will not be accepted.
- 4 A copy of the form must be included with all paperwork.
- 5 No product will be accepted freight collect.
- 6 We will not accept any parts returned on an invoice. They will be returned freight collect.
- 7 Any invoice issued for labor claims must include the RMA number assigned on this form, the 30-XXXXX number for the unit, and be invoiced for any labor claims within 30 days of the work completion. The allowable Vanair labor rate is \$65.00 per hour for all authorized work done in the United States.
- 8 All warranty claims must be pre-approved by Vanair or they will not be accepted.

Qty.	Part #	Description	Reason for return

Final Disposition of Goods		Notifications	Additional Notes
No Credit	Return to Customer	Quality Control	
Return to Stock	Issue Credit for Parts	Operations	
Scrap Goods	Issue Credit for Freight	Purchasing	
Ret to Vendor		Accounting	
Part Invoice #:		Shipping	

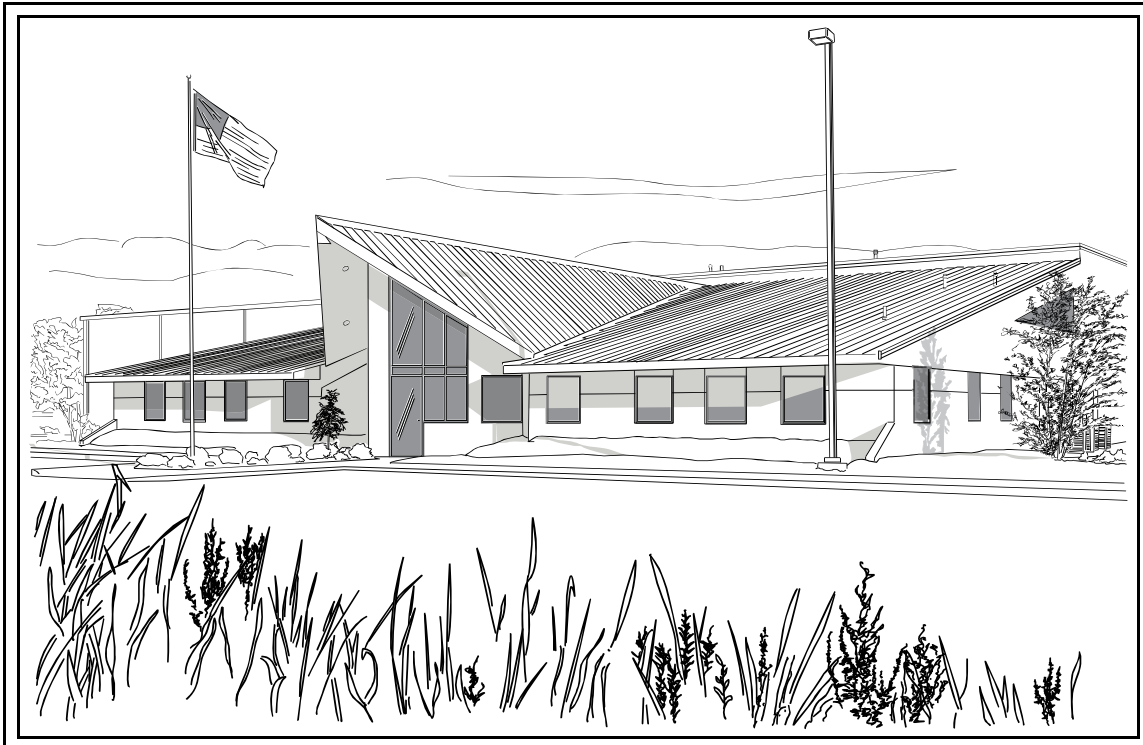

EXPERIENCE THE VANAIR® AIR N ARC ALL-IN-ONE POWER SYSTEM ADVANTAGE!

The Air N Arc All-In-One Power System is designed to provide compressed air, DC welding output, AC power, and battery boosting/charging in one easy to use interface.

This unit is designed to operate in an industrial environment, and with proper maintenance it should provide years of reliable service. This unit is weather-proof and able to operate in temperature extremes ranging from 0°F to 110°F (-18°C to 43°C); with available cold weather kit, operation further extends from below 0° to -40°F (-18°C to -40°C). Refer to **Section 5.8, Extreme Condition Operation**.

The AC generator features a brushless, maintenance-free design, and is completely separate from the DC welding generator.

The All-In-One Power System can support a multi-user operation. However, simultaneously using any two functions to their maximum output will cause a drop in RPM of the motor. This RPM drop will reduce the voltage output of the AC generator, which can cause damage to power tools being used. The operator must monitor the AC voltage at all times to insure proper voltage output.

This publication contains the latest information available at the time of preparation. Every effort has been made to ensure accuracy. However, Vanair® Manufacturing, Inc. takes no responsibility for errors or consequential damages caused by reliance on the information contained herein.

Vanair Manufacturing, Inc. reserves the right to make design change modifications or improvements without prior notification.

A NOTE ON MANUAL LAYOUT NAVIGATION

Refer to **Figure M-1**. This manual is presented in a two-column per page sequence. As shown in the figure, the inner columns represent the machine application data in a continuous page-by-page flow. The outer columns are reserved for auxiliary information relating to the specific data put forth in the inner column. This auxiliary data can, for example, be a relative warning or note detail. It will support the concept which is listed nearby in the inner column.

Sometimes, if an illustration is too large to fit in the outer column, or if a large table matrix is present, it may occupy the two-column space of a page. In such cases the inner column will always be continued on the next available page after the illustration.

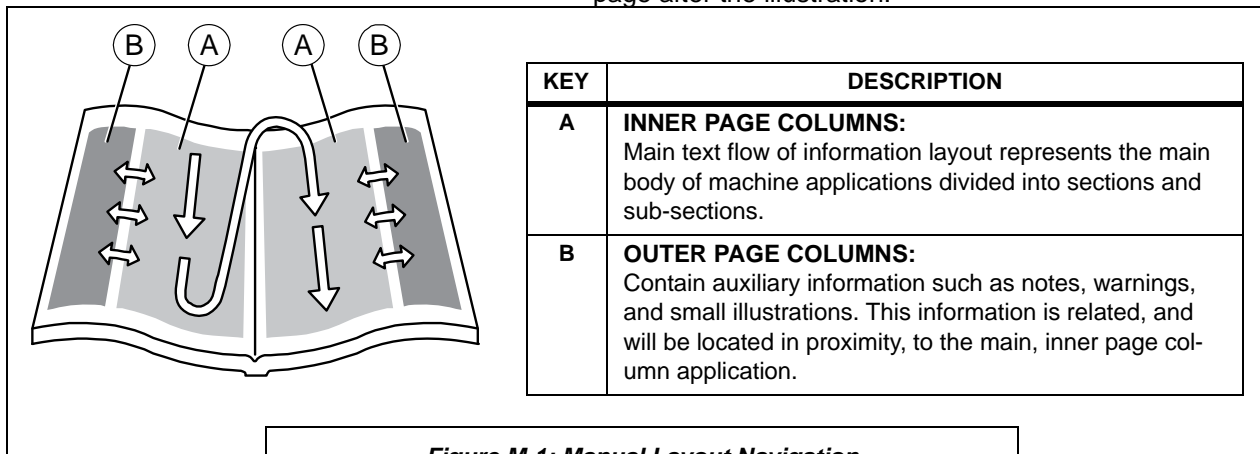

Figure M-1: Manual Layout Navigation

SECTION 1: SAFETY

1.1 GENERAL INFORMATION

The products provided by Vanair® Manufacturing, Inc., are designed and manufactured for safe operation and maintenance. But it is ultimately the responsibility of the users and maintainers for safe use of this equipment. Part of this responsibility is to read and be familiar with the contents of this manual before operation or performing maintenance actions.

1.2 DANGERS, WARNINGS, CAUTIONS, AND NOTES



IMPORTANT



It is mandatory that all operators read this manual before operating or servicing the Air N Arc 300 Series All-In-One Power System. Failure to do so could result in death, bodily injury or damage to equipment.



DANGER

Identifies actions or conditions which will cause death, severe injury, equipment damage or destructive malfunctions.



WARNING

Identifies actions or conditions which may cause death, severe injury, equipment damage or destructive malfunctions.



CAUTION

Identifies actions or conditions which will or can cause injuries, equipment damage or malfunctions.

NOTE

Additional information (or existing information) which should be brought to the attention of operators/maintainers affecting safety, operation, maintenance, or warranty requirements.

1.3 INTERNATIONAL SAFETY SYMBOL

The symbols shown and defined in **Section 1: Safety** are used throughout this manual to call attention to and identify possible hazards.



The international warning symbol shown above is used on all decals, labels and signs that concern information pertaining to bodily harm. When you see the international warning symbol, **pay extremely careful attention**, and follow the given instructions or indications to avoid any possible hazard.

1.4 ARC WELDING HAZARDS

1.4.1 ⚠️ ELECTRICAL SHOCK CAN KILL



Touching live electrical parts can cause fatal shocks or severe burns. The electrode and work circuit is electrically live whenever the output is on. The input power circuit and machine internal circuits are also live when power is on. In semiautomatic or automatic wire welding, the wire, wire reel, drive roll housing, and all metal parts touching the welding wire are electrically live. Incorrectly installed or improperly grounded equipment is a hazard.

Do not touch live electrical parts.

Wear dry, hole-free insulating gloves and body protection.

Insulate yourself from work and ground using dry insulating mats or covers big enough to prevent any physical contact with the work or ground.

Do not use AC output in damp areas, if movement is confined, or if there is a danger of falling.

Additional safety precautions are required when working in electrically hazardous conditions such as in damp locations or while wearing wet clothing; on metal structures such as floors, gratings, or scaffolds; when in cramped positions such as sitting, kneeling, or lying; or when there is a high risk of unavoidable or accidental contact with the work piece or ground.

Do not work alone!

Disconnect input power or stop motor before installing or servicing this equipment. Lockout/tag out input power according to OSHA29 CFR1910.147 (see **Section 1.9, Principal Safety Standards**).

Properly install and ground this equipment according to its Owner's Manual and national, state, and local codes.

Always verify the supply ground: check and be sure that input power cord ground wire is properly connected to ground terminal in disconnect box or that cord plug is connected to a properly grounded receptacle outlet.

When making input connections, attach proper grounding conductor first and double-check connections.

Frequently inspect input power cord for damage or bare wiring; replace cord immediately if damaged—bare wiring can kill.

Turn off all equipment when not in use.

Do not use worn, damaged, undersized, or poorly spliced cables.

Do not drape cables over your body.

If earth grounding of the work piece is required, ground it directly with a separate cable.

Do not touch electrode if you are in contact with the work, ground, or another electrode from a different machine.

Use only well-maintained equipment. Repair or replace damaged parts at once. Maintain unit according to manual.

Do not touch electrode holders connected to two welding machines at the same time since double open-circuit voltage will be present.

Wear a safety harness if working above floor level.

Keep all panels and covers securely in place.

Clamp work cable with good metal-to-metal contact to work piece or work table as near the weld as practical.

Insulate work clamp when not connected to workpiece to prevent contact with any metal object.

Do not connect more than one electrode or work cable to any single weld output terminal.

1.4.2 *FUMES AND GASES CAN BE HAZARDOUS*

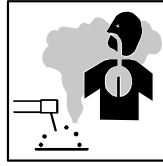

Welding produces fumes and gases. Breathing these fumes and gases can be hazardous to your health.

Keep your head out of the fumes. Do not breathe the fumes.

If inside, ventilate the area and/or use local forced ventilation at the arc to remove welding fumes and gases.

If ventilation is poor, wear an approved air-supplied respirator.

Read and understand the Material Safety Data Sheets (MSDS's) and the manufacturer's instructions for metals, consumables, coatings, cleaners, and degreasers.

Work in a confined space only if it is well ventilated, or while wearing an air-supplied respirator. Always have a trained watch person nearby.

Welding fumes and gases can displace air and lower the oxygen level causing injury or death. Be sure the breathing air is safe.

Do not weld in locations near degreasing, cleaning, or spraying operations.

The heat and rays of the arc can react with vapors to form highly toxic and irritating gases.

Do not weld on coated metals, such as galvanized, lead, or cadmium-plated steel, unless the coating is removed from the weld area, the area is well-ventilated, and while wearing an air-supplied respirator. The coatings and any metals containing these elements can give off toxic fumes if welded.

1.4.3 *BUILD UP OF GAS CAN INJURE OR KILL*

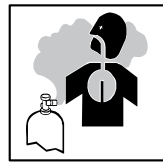

Shut off shielding gas supply when not in use.

Always ventilate confined spaces or use approved air-supplied respirator.

1.4.4 **⚠** *ENCLOSED SPACES CAN CAUSE A BUILD-UP OF NOXIOUS FUMES AND OVERHEATING*

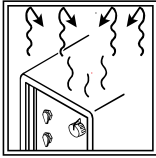

Do not use in enclosed spaces where deadly exhaust gases can build up and machine can overheat, causing fire.

1.4.5 **⚠** *ARC RAYS CAN BURN EYES AND SKIN*

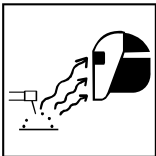

Arc rays from the welding process produce intense visible and invisible (ultraviolet and infrared) rays that can burn eyes and skin. Sparks fly off from the weld.

Wear an approved welding helmet fitted with a proper shade of filter lenses to protect your face and eyes from arc rays and sparks when welding or watching.

(See ANSI Z49.1 and Z87.1 listed in Safety Standards). Wear approved safety glasses with side shields under your helmet.

Use protective screens or barriers to protect others from flash, glare, and sparks; warn others not to watch the arc.

Wear protective clothing made from durable, flame-resistant material (leather, heavy cotton, or wool) and foot protection.

1.4.6 **⚠** *WELDING CAN CAUSE FIRE AND EXPLOSION*



Welding on closed containers, such as tanks, drums, or pipes, can cause them to blow up. Sparks can fly off from the welding arc. The flying sparks, hot workpiece, and hot equipment can cause fires and burns. Accidental contact of electrode to metal objects can cause sparks, explosion, overheating, or fire. Check and be sure the area is safe before doing any welding.

Remove all flammables within 35 ft (10.7 m) of the welding arc. If this is not possible, tightly cover them with approved covers.

Do not weld where flying sparks can strike flammable material.

Protect yourself and others from flying sparks and hot metal.

Be alert that welding sparks and hot materials from welding can easily go through small cracks and openings to adjacent areas.

Watch for fire, and keep a fire extinguisher nearby.

Be aware that welding on a ceiling, floor, bulkhead, or partition can cause fire on the hidden side.

Do not weld on closed containers such as tanks, drums, or pipes, unless they are properly prepared according to AWSF4.1 (See **Section 1.9, Principal Safety Standards**).

Connect ground cable as close to the welding area as practical to prevent welding current from traveling long, possibly unknown paths and causing electric shock, sparks, and fire hazards.

Do not use welder to thaw frozen pipes.

Remove stick electrode from holder or cut off welding wire at contact tip when not in use.

Wear oil-free protective garments such as leather gloves, heavy shirt, cuffless trousers, boots, and a cap.

Remove any combustibles, such as a butane lighter or matches, from your person before doing any welding.

Follow requirements in OSHA1910.252 (a) (2) (iv) and NFPA 51B for hot work and have a fire watcher and extinguisher nearby.

1.4.7 **FLYING METAL CAN INJURE EYES**

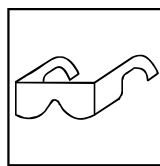

Sparks and flying metal can be caused by welding, chipping, wire brushing, and grinding. As welds cool, they can throw off slag.

Wear approved safety glasses with side shields even under your welding helmet.

1.4.8 ⚠️ HOT PARTS CAN CAUSE SEVERE BURNS

Do not touch hot parts bare handed.

Allow cooling period before working on equipment.

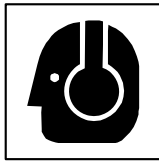
1.4.9 ⚠️ NOISE CAN DAMAGE HEARING

To handle hot parts, use proper tools and/or wear heavy, insulated welding gloves and clothing to prevent burns.

Noise from some processes or equipment can damage hearing.

Wear approved ear protection if noise level is high.

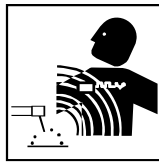
1.4.10 ⚠️ MAGNETIC FIELDS CAN AFFECT PACEMAKERS

Pacemaker wearers keep away.

Wearers should consult their doctor before going near arc welding, gouging, or spot welding operations.

Shielding gas cylinders contain gas under high pressure. If damaged, a cylinder can explode. Since gas cylinders are normally part of the welding process, be sure to treat them carefully.

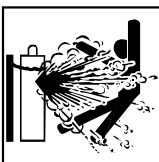
1.4.11 ⚠️ CYLINDERS CAN EXPLODE IF DAMAGED

Protect compressed gas cylinders from excessive heat, mechanical shocks, physical damage, slag, open flames, sparks, and arcs.

Install cylinders in an upright position by securing to a stationary support or cylinder rack to prevent falling or tipping.

Keep cylinders away from any welding or other electrical circuits.

Never drape a welding torch over a gas cylinder.

Never allow a welding electrode to touch any cylinder.

Never weld on a pressurized cylinder—explosion will result.

Use only correct shielding gas cylinders, regulators, hoses, and fittings designed for the specific application; maintain them and associated parts in good condition.

Turn face away from valve outlet when opening cylinder valve.

Keep protective cap in place over valve except when cylinder is in use or connected for use.

Use the right equipment, correct procedures, and sufficient number of persons to lift and move cylinders.

Read and follow instructions on compressed gas cylinders, associated equipment, and Compressed Gas Association (CGA) publication P-1 listed in Safety Standards.

1.5 HYDRAULIC SAFETY

1.5.1 AVOID HIGH PRESSURE FLUIDS

 IMPORTANT

Operator must be familiar with all safety precautions listed in the Motor Operator's Manual, in addition to the safety issues listed in this section.



Hydraulic hoses can fail due to physical damage, kinks, age, and exposure. Check hoses regularly and replace damaged hoses.

Escaping fluid under pressure can penetrate the skin, causing serious injury. Avoid the hazard by relieving pressure before disconnecting hydraulic or other lines. Tighten all connections before applying pressure.

Search for leaks with a piece of cardboard. Protect hands and body from high pressure fluids.

If an accident occurs, see a doctor immediately. Any fluid injected into the skin must be surgically removed within a few hours or gangrene may result. Doctors unfamiliar with this type of injury should reference a knowledgeable medical source. Such information is available from Deere & Company Medical Department in Moline, Illinois, U.S.A.

 WARNING
High pressure hydraulic system. Do not search for pinhole leaks with the hand or any other part of the body, as subcutaneous injection or amputation may result. Use a large piece of cardboard instead.

1.5.2 MOVING PARTS CAN CAUSE INJURY



Keep away from fans, belts, and rotors. Keep all doors, panels, covers, and guards closed and securely in place.

Stop motor before installing or connecting unit.

Have only qualified people remove doors, panels, covers, or guards for maintenance and troubleshooting as necessary.

Disconnect negative (-) battery cable from battery to prevent accidental starting during servicing.

Keep hands, hair, loose clothing, and tools away from moving parts.

Reinstall doors, panels, covers, or guards when servicing is finished and before starting motor.

Before working on generator, remove spark plugs or injectors to keep motor from kicking back or starting.

Block flywheel so that it will not turn while working on generator components.

1.5.3 **HOT PARTS CAN CAUSE SEVERE BURNS**



Do not touch hot parts bare handed.

Allow cooling period before working on equipment.

1.5.4 **ENCLOSED SPACES CAN CAUSE A BUILD-UP OF NOXIOUS FUMES AND OVERHEATING**

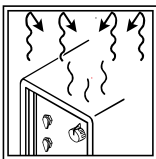

Do not use in enclosed spaces where deadly exhaust gases can build up and machine can overheat, causing fire.

1.6 COMPRESSED AIR HAZARDS

1.6.1 **BREATHING COMPRESSED AIR CAN CAUSE SERIOUS INJURY OR DEATH**

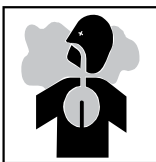

Do not use compressed air for breathing.

Use only for cutting, gouging, and tools.

1.6.2 ⚠ ENCLOSED SPACES CAN CAUSE A BUILD-UP OF NOXIOUS FUMES AND OVERHEATING

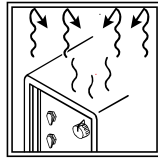

Do not use in enclosed spaces where deadly exhaust gases can build up and machine can overheat, causing fire.

1.6.3 ⚠ COMPRESSED AIR CAN CAUSE INJURY

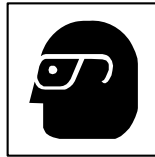

Wear approved safety goggles.

Do not direct air stream toward self or others.

1.6.4 ⚠ TRAPPED AIR PRESSURE AND WHIPPING HOSES CAN CAUSE INJURY

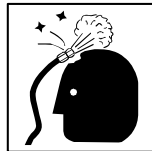

Release air pressure from tools and system before servicing, adding or changing attachments, or opening compressor oil drain or oil fill cap.

1.6.5 ⚠ HOT METAL FROM AIR ARC CUTTING AND GOUGING CAN CAUSE FIRE OR EXPLOSION



Do not cut or gouge near flammables.

Watch for fire; keep extinguisher nearby.

1.6.6 ⚠ HOT PARTS CAN CAUSE SEVERE BURNS



Do not touch hot parts bare handed.

Allow cooling period before working on equipment.

1.6.7  **READ INSTRUCTIONS**

Read Owner's Manual before using or servicing unit.
 Stop motor and release air pressure before servicing.
 Use only genuine Air-N-Arc replacement parts.

1.7 ADDITIONAL SYMBOLS FOR INSTALLATION, OPERATION AND MAINTENANCE**1.7.1**  **FALLING UNIT CAN CAUSE INJURY**

Use lifting bail to lift unit and properly installed accessories only.

Lift and support unit only with proper equipment and correct procedures.

If using lift forks to move unit, be sure forks are long enough to extend beyond opposite side of unit.

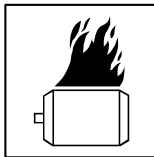
1.7.2  **OVERHEATING CAN DAMAGE MOTORS**

Turn off or unplug equipment before starting or stopping motor.

Do not let low voltage and frequency caused by low motor speed damage electric motors.

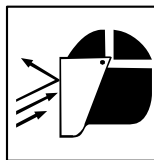
1.7.3  **FLYING SPARKS CAN CAUSE INJURY**

Wear a face shield to protect eyes and face.

Shape tungsten electrode only on grinder with proper guards in a safe location wearing proper face, hand, and body protection.

Sparks can cause fires—keep flammables away.

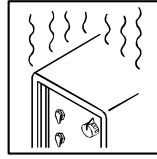
1.7.4 ⚠ OVERUSE CAN CAUSE OVERHEATING

Allow cooling period; follow rated duty cycle.

Reduce current or reduce duty cycle before starting to weld again.

Do not block or filter airflow to unit.

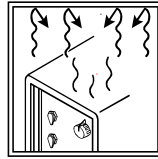
1.7.5 ⚠ ENCLOSED SPACES CAN CAUSE A BUILD-UP OF NOXIOUS FUMES AND OVERHEATING

Do not use in enclosed spaces where deadly exhaust gases can build up and machine can overheat, causing fire.

1.7.6 ⚠ TILTING OF TRAILER CAN CAUSE INJURY

Use tongue jack or blocks to support weight.

Properly install unit onto trailer according to instructions supplied with trailer.

1.7.7 ⚠ READ INSTRUCTIONS

Use only genuine Air N Arc replacement parts.

Perform motor and air compressor (if applicable) maintenance and service according to this manual and the motor/air compressor (if applicable) manuals.

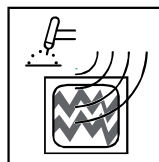
1.7.8 ⚠ H. F. RADIATION CAN CAUSE INTERFERENCE

High-frequency (H.F.) can interfere with radio navigation, safety services, computers, and communications equipment.

Have only qualified persons familiar with electronic equipment perform this installation.

The user is responsible for having a qualified electrician promptly correct any interference problem resulting from the installation.

If notified by the FCC about interference, stop using the equipment at once.

Have the installation regularly checked and maintained.

Keep high-frequency source doors and panels tightly shut, keep spark gaps at correct setting, and use grounding and shielding to minimize the possibility of interference.

1.7.9 **▲** *ARC WELDING CAN CAUSE INTERFERENCE*

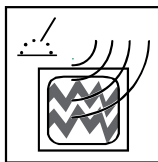

Electromagnetic energy can interfere with sensitive electronic equipment such as microprocessors, computers, and computer-driven equipment such as robots.

Be sure all equipment in the welding area is electromagnetically compatible.

To reduce possible interference, keep weld cables as short as possible, close together, and down low, such as on the floor.

Locate welding operation 100 meters from any sensitive electronic equipment.

Be sure this welding machine is installed and grounded according to this manual.

If interference still occurs, the user must take extra measures such as moving the welding machine, using shielded cables, using line filters, or shielding the work area.

1.8 **▲** CALIFORNIA PROPOSITION 65 WARNINGS

Welding or cutting equipment produces fumes or gases which contain chemicals known to the State of California to cause birth defects and, in some cases, cancer. (California Health & Safety Code Section 25249.5 et seq.)

Battery posts, terminals and related accessories contain lead and lead compounds, chemicals known to the State

of California to cause cancer and birth defects or other reproductive harm. Wash hands after handling.

For Gasoline Engines: Engine exhaust contains chemicals known to the State of California to cause cancer, birth defects, or other reproductive harm.

For Diesel Engines: Diesel engine exhaust and some of its constituents are known to the State of California to cause cancer, birth defects, and other reproductive harm.

1.9 ▲ PRINCIPAL SAFETY STANDARDS

Safety in Welding, Cutting, and Allied Processes, ANSI Standard Z49.1, from Global Engineering Documents (phone: 1-877-413-5184, website:www.global.ihs.com).

Recommended Safe Practices for the Preparation for Welding and Cutting of Containers and Piping, American Welding Society Standard AWSF4.1, from Global Engineering Documents (phone: 1-877-413-5184, web site: www.global.ihs.com).

National Electrical Code, NFPA Standard 70, from National Fire Protection Association, P.O. Box 9101, 1 Battery March Park, Quincy, MA 02269-9101 (phone: 617-770-3000, web site: www.nfpa.org and www.sparky.org).

Safe Handling of Compressed Gases in Cylinders, CGA Pamphlet P-1, from Compressed Gas Association, 1735 Jefferson Davis Highway, Suite 1004, Arlington, VA 22202-4102 (phone: 703-412-0900, web site: www.cganet.com).

Code for Safety in Welding and Cutting, CSA Standard W117.2, from Canadian Standards Association, Standards Sales, 178 Rexdale Boulevard, Rexdale, Ontario, Canada M9W 1R3 (phone: 800-463-6727 or in Toronto 416-747-4044, web site: www.csainternational.org).

Practice For Occupational And Educational Eye And Face Protection, ANSI Standard Z87.1, from American National Standards Institute, 11West 42nd Street, New York, NY10036-8002 (phone: 212-642-4900, web site: www.ansi.org).

Standard for Fire Prevention During Welding, Cutting, and Other Hot Work, NFPA Standard 51B, from National Fire Protection

Association, P.O. Box 9101, 1 Battery March Park, Quincy, MA 02269-9101 (phone: 617-770-3000, web site: www.nfpa.org).

OSHA, Occupational Safety and Health Standards for General Industry, Title 29, Code of Federal Regulations (CFR), Part 1910, Subpart Q, and Part 1926, Subpart J, from U.S. Government Printing Office, Superintendent of Documents, P.O. Box 371954, Pittsburgh, PA 15250 (there are 10 Regional Offices; phone for Region 5, Chicago, is 312-353-2220, web site: www.osha.gov).

1.10 EMF INFORMATION

Considerations About Welding And The Effects Of Low Frequency Electric And Magnetic Fields Welding current, as it flows through welding cables, will cause electromagnetic fields.

There has been and still is some concern about such fields. However, after examining more than 500 studies spanning seventeen years of research, a special blue ribbon committee of the National Research Council concluded that: "The body of evidence, in the committee's judgment, has not demonstrated that exposure to power-frequency electric and magnetic fields is a human-health hazard." However, studies are still going forth and evidence continues to be examined. Until the final conclusions of the research are reached, you may wish to minimize your exposure to electromagnetic fields when welding or cutting.

To reduce magnetic fields in the workplace, use the following procedures:

1. Keep cables close together by twisting or taping them.
2. Arrange cables to one side and away from the operator.
3. Do not coil or drape cables around your body.
4. Keep welding power source and cables as far away from operator as possible.
5. Connect work clamp to workpiece as close to the weld as possible.

About Pacemakers:

Pacemaker wearers consult your doctor before welding or going near welding operations. If cleared by your doctor, then following the above procedures is recommended.

1.11 MACHINE CANOPY ACCESS SAFETY SWITCHES

Consult **Figure 1-1**. The Air N Arc 300 Series machine package is equipped with a safety switch, which will shut down the machine if access door is bridged.

The **rear door safety switch** will not allow the machine to run if an attempt to remove or open the access panel occurs. Under condition of the machine running, if the switch is triggered, the machine will shut down.

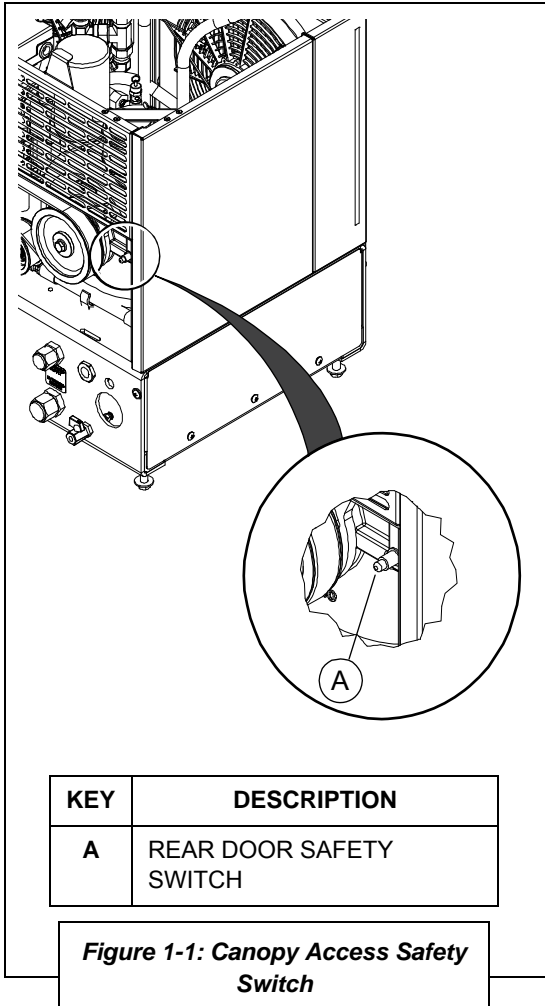

	CAUTION
<p>The machine is not designed to run with the hood open as standard operating procedure.</p> <p>This unit will run with the hood open. Extreme care needs to be taken when checking this unit's components, as it can automatically start.</p>	

1.12 DISPOSING OF MACHINE FLUIDS

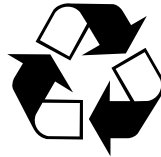

Always dispose of machine fluids under the guidance of all applicable local, regional and/or federal law.

Vanair® encourages recycling when allowed. For additional information, consult the container.

Figure 2-1: MAJOR MACHINE COMPONENTS LOCATIONS¹

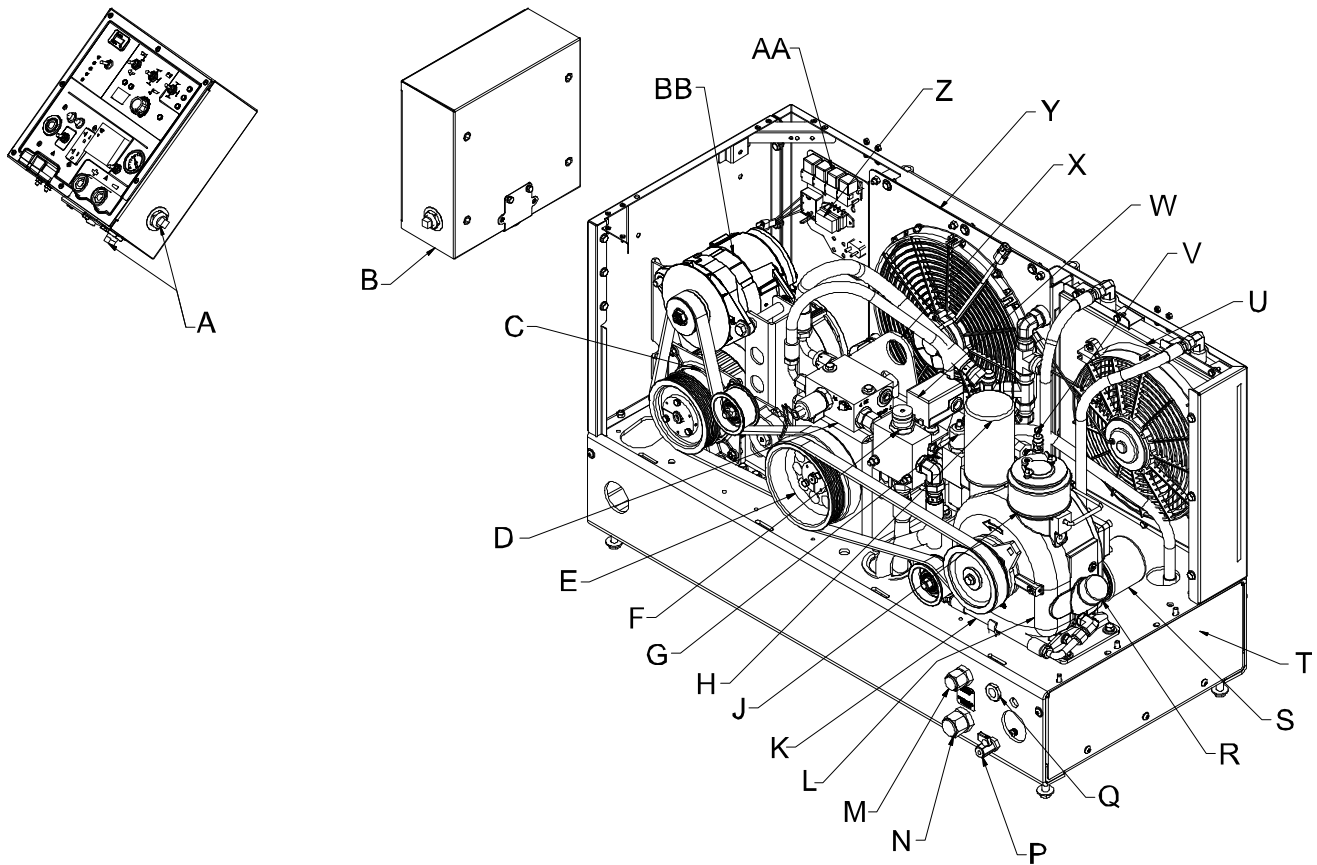

KEY	DESCRIPTION	KEY	DESCRIPTION
A	AIR OUT	Q	AIR OUT
B	PANEL	R	COMPRESSOR FLUID FILL PORT
C	A/C GENERATOR	S	COMPRESSOR OIL FILTER
D	HYDRAULIC MANIFOLD	T	AIR TANK RESERVOIR (4 GAL.)
E	HYDRAULIC MOTOR	U	COMPRESSOR OIL COOLER
F	FLOW CONTROLLER	V	PRESSURE RELIEF VALVE (200 PSI)
G	MINIMUM PRESSURE VALVE	W	PRESSURE SWITCH
H	AIR/OIL COALESCER	X	LIFTING BAIL
J	AIR FILTER COMPRESSOR	Y	HYDRAULIC COOLER
K	COMPRESSOR OIL DRAIN TUBE	Z	FUSES
L	COMPRESSOR UNIT	AA	RELAYS
M	HYDRAULIC SUPPLY	BB	DC GENERATOR
N	HYDRAULIC RETURN		
P	AIR MOISTURE DRAIN		

¹Refer to **Section 9** for part description details and part numbers.

NOTE: The above figure is an “at-a-glance” view of the 300 package. Component detail is covered in-depth in **Section 2**.

NOTE: For information on motor components, refer to **Section 2.4**, or the Motor Operator’s Manual.

SECTION 2: DESCRIPTION

2.1 GENERAL DESCRIPTION

Vanair® Manufacturing, Inc.'s Air N Arc 300 Series All-In-One Power System offers superior performance and reliability, as well as limited maintenance requirements.

The Power System package is designed to provide compressed air, DC welding output, AC power, and battery boosting/charging in one easy to use interface.

This section of the manual provides brief descriptions of the components and systems on the Air N Arc 300 Series All-In-One Power System package. See **Figure 2-1** for a quick visual guide to the Power System's main component locations.

2.2 COMPRESSED AIR SYSTEM

System Component or Component Group	Manual Section	Location
COMPRESSED AIR SYSTEM	2.2	page 21
Compressor Unit	2.2.1	page 21
Electronic Air Inlet Valve	2.2.2	page 22
Air Inlet Filter	2.2.3	page 23
Secondary Spin-on Air/Oil Coalescer	2.2.4	page 23
Minimum Pressure/Check Valve	2.2.5	page 23
Pressure Relief Valve	2.2.6	page 23
Adjustable Pressure Switch	2.2.7	page 24
Oil Reservoir and Primary Air/Oil Separator	2.2.8	page 24

2.2.1 COMPRESSOR UNIT

See **Figure 2-2**. The compressor is a single-stage, positive-displacement, oil-flooded, rotary screw type compressor. Rotary screw compressors function by injecting oil into the compressor unit and mixing it directly with the air as both air and oil are forced through the rotating screws in the compression chamber. Because of this concept, compressed air is generated on demand

NOTE



Read this manual before operating or servicing this equipment. Failure to comply with the operation and maintenance instructions in this manual WILL VOID THE EQUIPMENT WARRANTY.

This manual should be read in conjunction with other appropriate supplied manuals, such as the Motor Operator's manual, or Generator Operator's manual.

NOTE

Refer to the Maintenance Section of this manual for adjustment and replacement procedures.

NOTE

Refer to the provided Motor Operator's Manual for service and maintenance recommendations that are not provided in this manual.

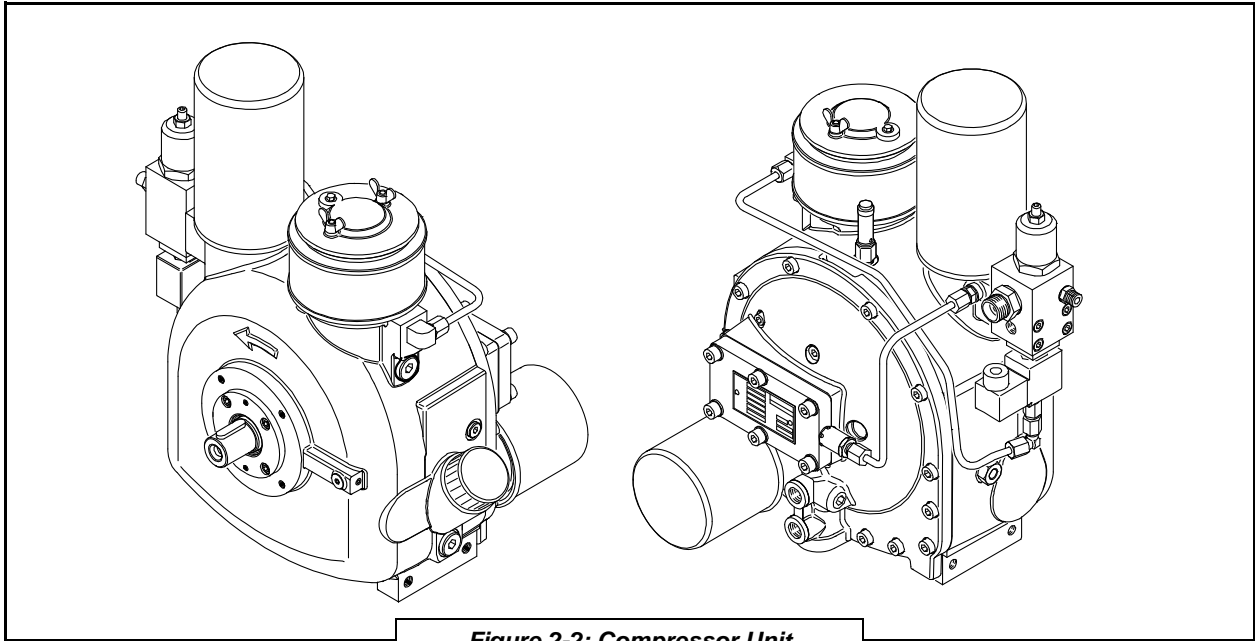

Figure 2-2: Compressor Unit

and eliminates the need for a separate air reservoir. Internal porting also lubricates the bearings and seals by using pressure differentials.

The oil has three primary functions: coolant, sealant, lubricant. The oil carries the heat associated with compressing air to an air-to-oil heat exchanger. It also seals the clearances between the rotors and the stator housing, as well as between the rotors themselves. Lastly, the oil lubricates the rotors and the bearings and seal, allowing one rotor to drive the other, which is an idler.

The rotors are mounted inside the main casting and consist of a male and female rotor supported with low-friction bearings sized for a long, useful life.

2.2.2 ELECTRONIC AIR INLET VALVE

See **Figure 2-3**. The electronically-actuated air inlet valve is a piston-type valve located directly on top of the compressor assembly, beneath the air inlet filter. On initial start-up, the solenoid is energized and the inlet valve opens due to pilot air being passed through the solenoid actuated valve. When operating pressure is reached, the pressure switch (**Figure 2-6**) de-activates the solenoid and the inlet valve closes. At the same time, the compressor pressure will unload to a lower pressure (typically about 40 psig). Only the compressed air within the compressor unit will reduce due to the operation of the minimum pressure/check valve. This reduction in

internal air pressure reduces the power requirement considerably during this unloaded state. The pressure switch will re-activate the solenoid valve allowing the inlet valve to open upon sensing an air demand (reduced pressure). This will allow the compressor to start producing air again.

2.2.3 AIR INLET FILTER

See **Figure 2-3**. The air inlet filter, which is integrated into the compressor assembly, is a dry type replaceable element that drops in directly on top of the inlet valve assembly. It is accessible by removing the cover from the top of the filter assembly. For routine maintenance of the air filter, consult **Sections 6.2** and **6.3** for maintenance schedules, and **Section 6.6.1** for specific air filter maintenance procedures.

2.2.4 SECONDARY SPIN-ON AIR/OIL COALESCER

See **Figure 2-4**. The compressor assembly is fitted with a secondary spin-on air/oil coalescer. The coalescer element recovers the finer particles of residual oil that remain in the air after primary separation occurs. The oil that is collected in this element is “scavenged” back to the compressor unit for re-use. This element will need to be replaced from time to time as part of normal maintenance. For routine maintenance of the spin-on air/oil coalescer consult **Sections 6.2** and **6.3** for schedule intervals, and **Section 6.6.6** for the specific coalescer maintenance procedure.

2.2.5 MINIMUM PRESSURE/CHECK VALVE

See **Figure 2-4**. This combination valve, located on the control manifold, serves two functions. First, the minimum pressure valve maintains a pressure of approximately 65 psig in the compressor to ensure oil injection during load conditions and also to maintain effective oil separation. Once this internal pressure is exceeded, it will allow air to pass downstream to the service outlet. The discharge check valve prevents air in the service line from venting down through the compressor during unload.

2.2.6 PRESSURE RELIEF VALVE

See **Figure 2-5**. The pressure relief valve is the last safety device that will be activated. It is a spring-backed normally closed valve that will vent excess pressures to the atmosphere when excessive pressures are reached. The Air N Arc 300 Series Power System is equipped with a 200 psig relief valve. As the pressure begins to

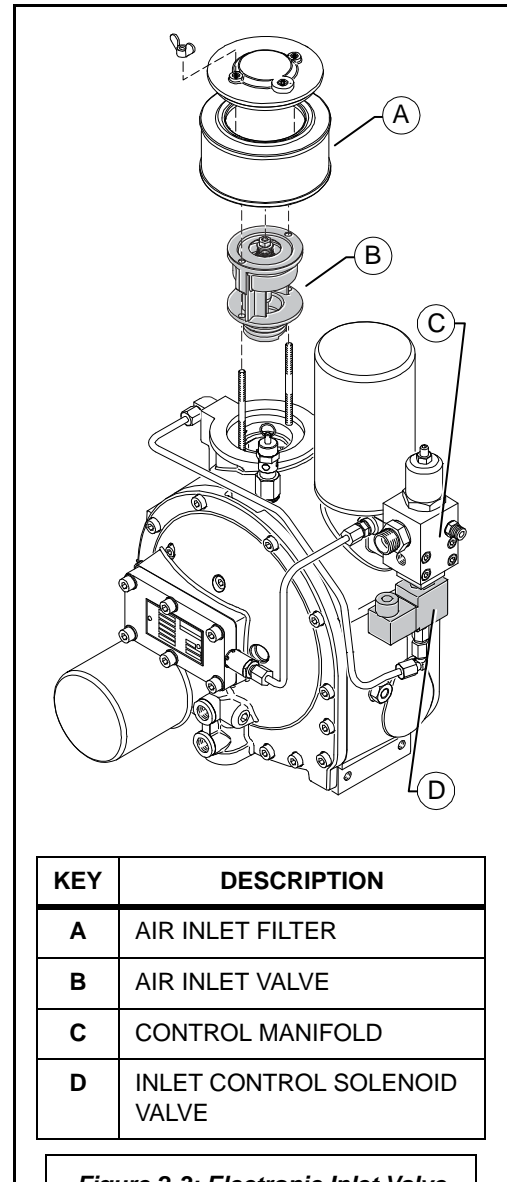

WARNING

Compressor oil can ignite if it comes in contact with very hot surfaces.

NOTE

Refer to the Maintenance Section of this manual for adjustment and replacement procedures.

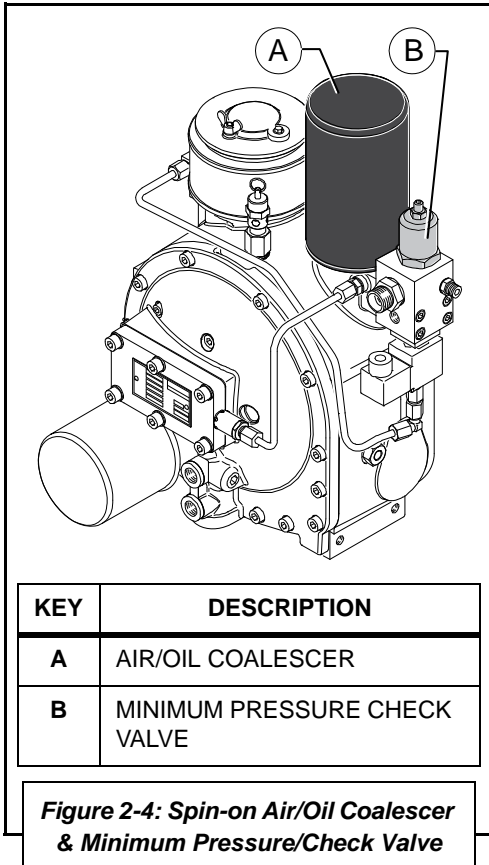

approach 200 psig, it will crack open to slowly relieve pressure. If pressure continues building through this venting, it will be fully open at 200 psig. Both air and oil will be expelled from this valve.

2.2.7 ADJUSTABLE PRESSURE SWITCH

See **Figure 2-6**. The adjustable pressure switch is near the lift bale bracket, and is plumbed into pressure on the upstream side of the minimum pressure valve. The purpose of the switch is to provide a control for the inlet valve control solenoid, much like a pneumatic regulator valve. When the pressure in the service line drops below the set limit, it reactivates the inlet valve control solenoid, allowing the inlet valve to suck in more air. The pressure switch has both a high and low pressure setting.

Although the pressure cut-in and cut-out pressures are pre-set at the factory, they may be manually adjusted. For procedure on pressure control switch adjustment, see **Section 6.6.14**.

2.2.8 OIL RESERVOIR AND PRIMARY AIR/OIL SEPARATOR

The main casting of the compressor unit, which contains the screw compressor, is also the oil reservoir and primary oil separation unit. The initial (primary) oil separation is caused by both changes in velocity and direction. The main casting also contains the oil fill tube and drain hose assembly. A separate oil reservoir is not required.

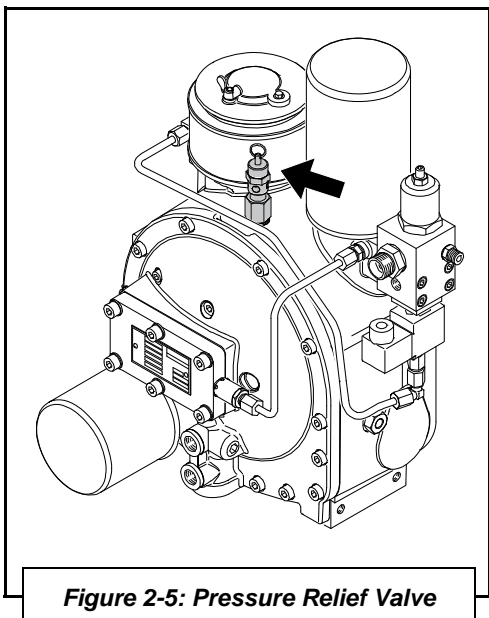

2.3 OIL COOLING SYSTEM

System Component or Component Group	Manual Section	Location
OIL COOLING SYSTEM	2.3	page 24
Compressor Temperature and Pressure Switches	2.3.1	page 26
Compressor Spin-on Oil Filter	2.3.2	page 26

See **Figure 2-7**. The machine package cooling system consists of two (2) main heat exchange units identified in **Figure 2-7**, and the following explanation.

The hydraulic system lubricant is air-cooled via the hydraulic cooler [A]. The compressor system lubricant is air-cooled via the compressor-cooler portion [B].

Both fans draw air through the machine, past the cooler, and out of the package. The hydraulic fan is turned on by

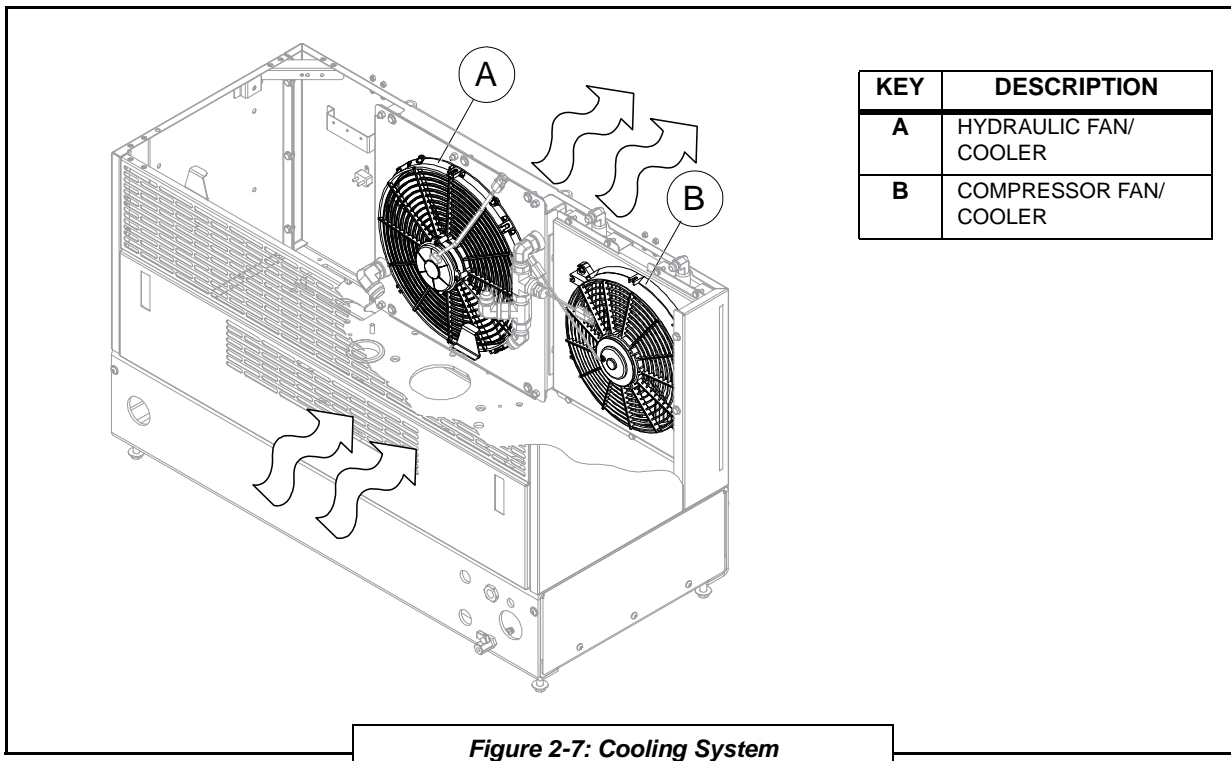
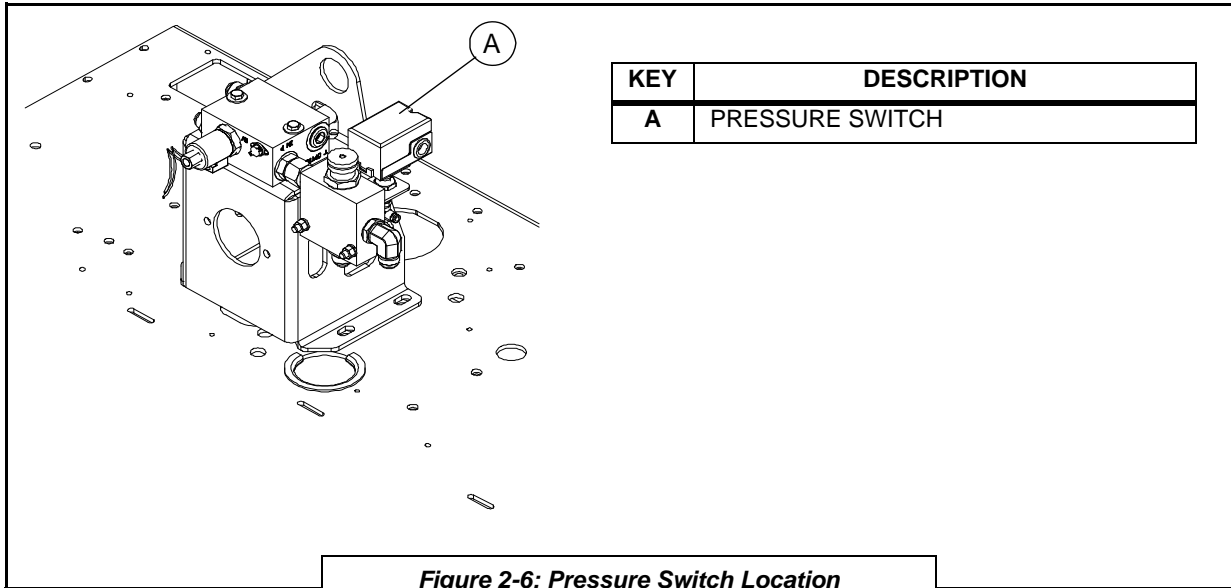

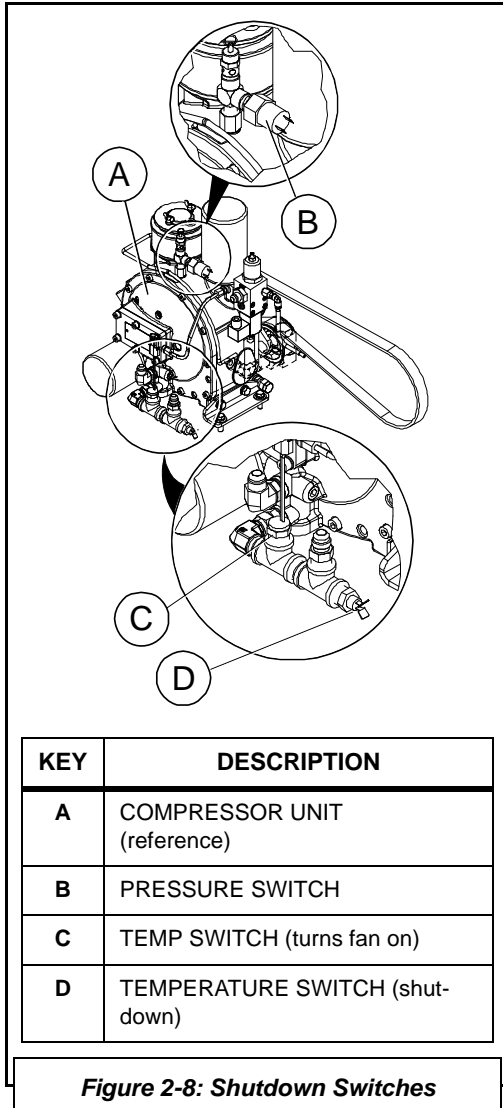

Figure 2-8: Shutdown Switches

NOTE

Do not tamper with the flow control setting to increase the maximum motor speed. Overspeed is hazardous and will void the motor warranty.

the hydraulic oil temperature switch. The compressor fan is turned on by the compressor oil temperature switch.

The compressor cooling system allows for the compressor lubricant temperature to be maintained to a minimum of approximately 160°F (71°C). The elevated temperature forces the moisture, which may be ingested into the compressor system due to atmospheric humidity, to stay in a state of vapor. This prevents the moisture from condensing out in the system and contaminating the lubricant.

The cooler core for the 300 Series Power System relies on the cooling fan to draw fresh air from outside the package across the core to cool the compressor lubricant. The maximum lubricant temperature is maintained by using an integral compressor thermal valve.

The oil cooling system is composed of the following main components:

2.3.1 COMPRESSOR TEMPERATURE AND PRESSURE SWITCHES

See **Figure 2-8**. The compressor is equipped with two switches that can shut down the unit should over-limit conditions occur. The temperature shuts down at 240°F (116°C). The pressure switch shuts down machine at 185 psi.

2.3.2 COMPRESSOR SPIN-ON OIL FILTER

See **Figure 2-9**. The compressor system is also supplied with a spin-on oil filter, positioned off the lower corner of the compressor. This element requires regular replacement to prolong the life of the compressor system. For routine maintenance of the spin-on filter, consult **Sections 6.2** and **6.3** for maintenance schedules, and **Section 6.6.4** for specific compressor oil filter maintenance procedures.

2.4 MOTOR

The drive systems from the motor to both the compressor and generator are accomplished with two micro V-belt systems. Both of these systems have provisions for belt tensioning, should the belts become stretched out over time (refer to **Section 6.6.15**).

2.5 AC GENERATOR

See **Figure 2-10**. The AC generator utilized on the 300 Series package is a 2-pole, single phase, 2-bearing,

brushless style. These units should not require maintenance since they do not have slip rings, nor slipping contacts. The end brackets are die-cast in a high resistance aluminum alloy, the shaft is C45 steel, and is fitted with a keyed fan. A 20 and 25 amp, in series circuit breaker protection is also included.

 WARNING
<p>DO NOT rely on breakers for overload protection.</p> <p>These breakers are temperature and time dependant, and cannot be relied upon for overload protection.</p>

2.6 INSTRUMENTATION

This section describes the basic functions of the controls located on the instrument panel. To insure that the controls are engaged correctly, Consult the various operating procedures as described in **Section 5, Operation.**

System Component or Component Group	Manual Section	Location
INSTRUMENTATION	2.6	page 27
Volts/Amps Meter	2.6.1	page 28
Welder Function Switches	2.6.2	page 28
DC Charger Mode Toggle Switch	2.6.3	page 28
Volts/Amps Manual Adjustment Dial	2.6.4	page 28
Compressor Air Pressure Gauge	2.6.5	page 28
Compressor ON/OFF Toggle Switch	2.6.6	page 29
Welder Lead Junction	2.6.7	page 29
Hz /Voltage Meter	2.6.8	page 29
Battery Cable Receptacle	2.6.9	page 29
Generator Control ON/OFF Switch	2.6.10	page 29
AC Voltage Outlets	2.6.11	page 29
Circuit Breaker Overload Trip/Reset Buttons	2.6.12	page 31
Front Access Panel Open Indicator Lamp	2.6.13	page 31
Compressor Over Pressure Indicator Lamp	2.6.14	page 31
Compressor Overtemp Indicator Lamp	2.6.15	page 31
Hydraulic Overtemp Indicator Lamp	2.6.16	page 31

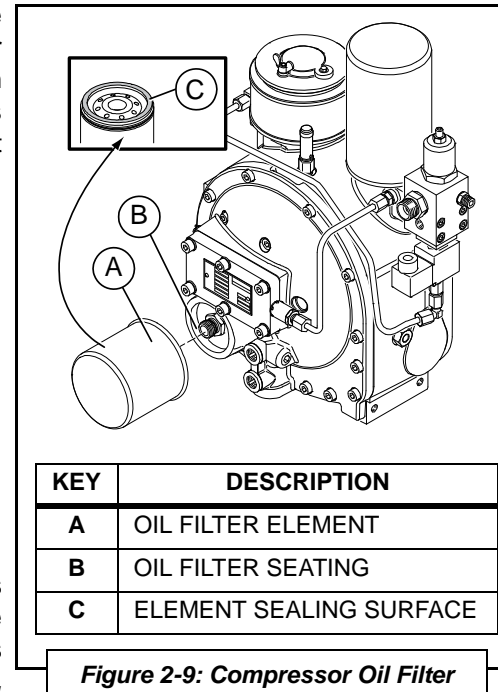

Figure 2-9: Compressor Oil Filter

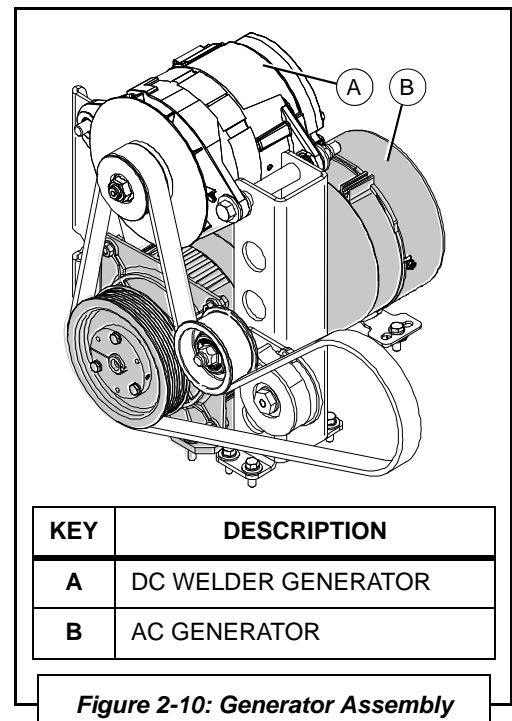

Figure 2-10: Generator Assembly

System Component or Component Group	Manual Section	Location
Motor ON/RESET Switch	2.6.17	page 31
Hour Meter	2.6.18	page 32

See **Figure 2-11**. The standard instrument panel for the Air N Arc 300 Series contains a volts/amps meter, welder function switches, DC charger mode toggle switch, volts/amps manual adjustment dial, compressor ON/OFF toggle switch, compressor air pressure gauge, welder lead junction and battery cable receptacle, generator control ON/OFF switch, AC voltage outlets, circuit breaker overload trip/reset buttons, machine control (ON/RESET) switch and hour meter.

In addition the panel contains function indicator lamps that light to show various machine operation conditions. These include: the door open indicator lamp, high compressor temperature indicator lamp, high hydraulic temperature indicator lamp.

2.6.1 VOLTS/AMPS METER

The **volts/amps meter** shows the amount of volts and/or amp level while welding or boosting.

2.6.2 WELDER FUNCTION SWITCHES

The **constant current (CC) or constant voltage (CV) toggle switch** lets the operator choose the type of power supply desired.

- CC Mode = Constant Current
- CV Mode = Constant Voltage

The three-position **DC charger/welder toggle switch** serves as the battery charge enabling switch, power-enabling switch for welding, or the disabling (OFF) switch for the welding function.

2.6.3 DC CHARGER MODE TOGGLE SWITCH

The three-position **DC charger mode toggle switch** lets the operator choose the type of charge needed from 12V center (default), 12V boost or 24V boost options. This is a momentary switch; the lights will indicate the mode selected.

2.6.4 VOLTS/AMPS MANUAL ADJUSTMENT DIAL

The **volts/amps manual adjustment dial** allows the operate to manually increase or decrease the amount of

amperage or voltage, in variable increments, for the desired weld heat.

2.6.5 COMPRESSOR AIR PRESSURE GAUGE

The **compressor air pressure switch/gauge** indicates the discharge air pressure.

IMPORTANT

DO NOT OPEN the instrument panel box. Opening the instrument panel box will void the warranty.

2.6.6 COMPRESSOR ON/OFF TOGGLE SWITCH

The **compressor ON/OFF toggle switch** engages the air compressor system.

NOTE

If requiring maximum power from AC or DC generator, turn this switch OFF.

2.6.7 WELDER LEAD JUNCTION

The **welder lead junction** contains the positive and negative interface connections for the standard welding lead cable.

2.6.8 HZ/VOLTAGE METER

The **Hz/Voltage meter** informs the user if the machine is at the proper speed. With the machine running, no load applied and the generator switch ON, this meter should read 61.5 Hz. This reading is actually between the green light and the red light, so as long as the green light or the green and red light (located to the right of it) are on, the machine is at proper speed.

If under use, the user only sees three (3) red lights, then the load is too heavy and should be reduced.

The voltage is also shown on this meter, but is only accurate during AC use. When the generator switch is ON but the generator is not being used, the voltage is inaccurate.

NOTE

This meter calibrates by turning on all lights upon power up, which can be misconstrued as over speed. If all lights flash on this component, this is NOT a sign of overspeed.

2.6.9 BATTERY CABLE RECEPTACLE

The **battery cable receptacle** junction contains the interface connections for the battery cables when charging the battery from the DC charger. The battery cable receptacle contains a weather-resistant cap.

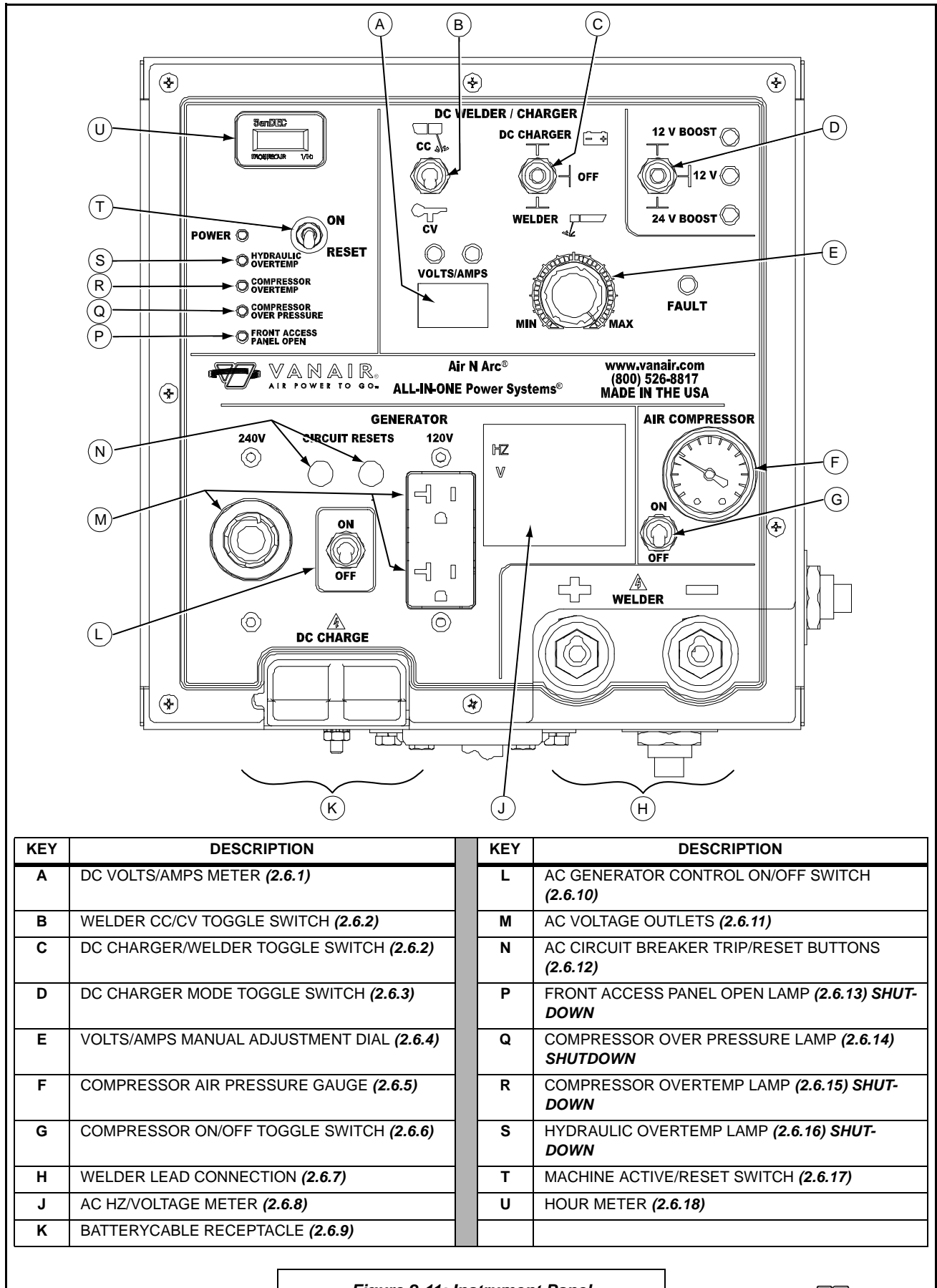

KEY	DESCRIPTION
A	DC VOLTS/AMPS METER (2.6.1)
B	WELDER CC/CV TOGGLE SWITCH (2.6.2)
C	DC CHARGER/WELDER TOGGLE SWITCH (2.6.2)
D	DC CHARGER MODE TOGGLE SWITCH (2.6.3)
E	VOLTS/AMPS MANUAL ADJUSTMENT DIAL (2.6.4)
F	COMPRESSOR AIR PRESSURE GAUGE (2.6.5)
G	COMPRESSOR ON/OFF TOGGLE SWITCH (2.6.6)
H	WELDER LEAD CONNECTION (2.6.7)
J	AC HZ/VOLTAGE METER (2.6.8)
K	BATTERYCABLE RECEPTACLE (2.6.9)

KEY	DESCRIPTION
L	AC GENERATOR CONTROL ON/OFF SWITCH (2.6.10)
M	AC VOLTAGE OUTLETS (2.6.11)
N	AC CIRCUIT BREAKER TRIP/RESET BUTTONS (2.6.12)
P	FRONT ACCESS PANEL OPEN LAMP (2.6.13) SHUT-DOWN
Q	COMPRESSOR OVER PRESSURE LAMP (2.6.14) SHUTDOWN
R	COMPRESSOR OVERTEMP LAMP (2.6.15) SHUT-DOWN
S	HYDRAULIC OVERTEMP LAMP (2.6.16) SHUT-DOWN
T	MACHINE ACTIVE/RESET SWITCH (2.6.17)
U	HOUR METER (2.6.18)

Figure 2-11: Instrument Panel

2.6.10 GENERATOR CONTROL ON/OFF TOGGLE SWITCH

The **generator control ON/OFF switch** engages the AC generator. When off, the outlets are de-energized.

2.6.11 AC VOLTAGE OUTLETS

The **AC voltage outlets** allow for AC generator power access via two 120V, and one 240V receptacles.

2.6.12 CIRCUIT BREAKER OVERLOAD TRIP/RESET BUTTONS

The **reset-capable circuit breakers** are used to protect the generator circuits from damage if an overload or short circuit situation occurs. The circuit breaker will trip and can be easily reset by pushing the button.

Whenever a circuit breaker trips, always check the complete system for any possible faulty conditions before resetting the system. If trouble persists, consult **Section 7, Troubleshooting**, or the Vanair® Service Department.

2.6.13 FRONT ACCESS PANEL OPEN INDICATOR LAMP

The **front access panel open indicator lamp signals** that the front panel is not in place, or not fastened properly; the machine will not start if the door panel is open.

2.6.14 COMPRESSOR OVER PRESSURE INDICATOR LAMP

If the compressor system sees 185+ psi, the machine will shut down and cause this lamp to flash. After the problem has been corrected, manually toggle the ON/RESET switch to restart the machine.

NOTE

If the problem has not been corrected, the machine will not start.

2.6.15 COMPRESSOR OVERTEMP INDICATOR LAMP

The **high temperature indicator lamp** signifies that the compressor has shut down due to excessive oil temperature (240°+F).

IMPORTANT

Do not force the reset buttons if they remain fixed in their inset positions—if the buttons are tripping frequently, or do not reset, this is an indication of a system problem.

NOTE

All shut downs are bypassed for ten (10) seconds to allow for cranking.

NOTE

Any time the motor control switch is on, the hour meter is running.

2.6.16 HYDRAULIC OVERTEMP INDICATOR LAMP

The **hydraulic overtemp indicator lamp** signifies that the machine has shut down due to excessive hydraulic oil temperature (180°F).

2.6.17 MACHINE CONTROL (RESET) SWITCH

The **machine activation switch** engages the phases of the motor, which is integral to all the functions of the 300 Series Power System. Consult the various operating procedures as found in **Section 4, Operation**, to determine the integration of the motor with each separate system function.

If shutdown occurs, this switch must be reset and turned back on for operation after the problem has been fixed.

2.6.18 HOUR METER

The **hour meter** records the total accumulated hours that the package is operated. The hour meter can be used to assist in scheduled maintenance planning.

The meter only records hours when the motor is running (not while bypassing).

SECTION 3: SPECIFICATIONS

TABLE 3A: SPECIFICATIONS - WELDER AND GENERATOR

SYSTEM INFORMATION	SPECIFICATION
Rated Welder Output	300A High Frequency DC/CC, DC/CV; 100% Duty Cycle @ 280 Amps
Welding Leads	25 or 50 Ft Optional (Refer to Section A.5 for Optional Parts Listing)
AC Generator	6800 Watts Continuous Duty (Capacitor style)
AC Generator 120V Power Rating	60 Hz 1 PH, 2-20 Amp Circuits
AC Generator 240V Power Rating	60 Hz 1 PH, 28 Amp
Battery Charger Capacity	12V Charge, 12V Boost, 24V Boost

TABLE 3B: SPECIFICATIONS - MOTOR

MOTOR INFORMATION	SPECIFICATION
Motor	17.7 GPH (3000 RPM) (2800 PSI Maximum Working Pressure)
Fluid	Mineral Oil Based Hydraulic Fluids to ISO/DIN
Viscosity	From 60 to 456 SSU [12 to 100mm ² / ₅ (cSt)] rec. up to 3410 SSU[750mm ² / ₅ (cSt)] permitted.
Filtration	Contamination class NAS1638:9; ISO 4406:20/18/15. Achieved with filter β ₁₀ (c) ≥ 75:10mm
Operating Temperature Limits	0°F to 110°F (-18°C to 43°C); Cold Weather Kit extends temperature range from 0°F to -40°F (-18°C to -40°C)

TABLE 3C: SPECIFICATIONS — AIR COMPRESSOR

COMPRESSOR INFORMATION	SPECIFICATION
Compressor Type	Single Stage, Oil Injected Rotary Screw
Air Compressor Capacity	40 CFM @ 175 PSI
Inlet Control	Zero (0) No Load / 100% Load
Air Filter	Pleated Paper, Dry Type
Oil Filter	Spin-on Type
Oil Capacity/Type	New: 3 Quarts / Service: 2 Quarts [Vanguard™ Premium Synthetic Oil]
Air Tank Capacity	Four (4) Gallons
Tank Pressure Rating	200 PSI
Safety Relief Valve Setting	200 PSI
Operating Range (ambient)	0° to 110°F (-18°C to 43°C); Cold Weather Kit needed for operating below 0°F(-18°C)
Electrical System	12 VDC
Cooling System	Air to Oil Heat Exchanger
Instrument Gauges	Pressure and Hour Meter
Adjustable Air Pressure Control Settings	Cut-in Pressure: 100 PSI / Cut-out Pressure: 125 PSI (Factory Preset); 150/175 PSI (Maximum Cut-in/Cut-out)
Air Service Outlets	Two (2) on Control Panel, One (1) on Machine





TABLE 3D: SPECIFICATIONS — UNIT WEIGHT AND DIMENSIONS^I

Dimensions	Length	Width	Height	Weight ^{II} (wet)	Weight ^{II} (dry)
Overall Package	47.5"	21"	33"	980 lbs.	870 lbs.

^ISee **Diagram 4.5** (parts 1 and 2) for full dimension drawing, and **Figure 4-1** for location space requirements.

^{II}Weight listed includes battery and fuel tank, but not instrument panel: Add 25 lbs. to weights above for instrument panel.

TABLE 3E: BOLT AND TORQUE SPECIFICATIONS

	 SAE 2	 SAE 5	 SAE 7	 SAE 8	
	2	5	7	8	SOCKET HEAD CAP SCREW
I.D. Marks	No markings	3 lines	5 lines	6 lines	Allen head
Material	Low carbon	Medium -carbon, tempered	Medium - carbon, quenched & tempered	Medium carbon, quenched & tempered	High-carbon, quenched & tempered
Tensile strength (minimum)	74,000 psi	120,000 psi	133,000 psi	150,000 psi	160,000 psi

US BOLT TORQUE SPECIFICATIONS (Torque in foot-pounds)

Bolt Diameter	Thread per inch	2		5		7		8		Socket head cap screw	
		Dry	Oiled	Dry	Oiled	Dry	Oiled	Dry	Oiled	Dry	Oiled
1/4	20	4	3	8	6	10	8	12	9	14	11
1/4	28	6	4	10	17	12	9	14	10	16	13
5/16	18	9	7	17	13	21	16	25	18	29	23
5/16	24	12	9	19	14	24	18	29	20	33	26
3/8	16	16	12	30	23	40	30	45	35	49	39
3/8	24	22	16	35	25	45	35	50	40	54	44
7/16	14	24	17	50	35	60	45	70	55	76	61
7/16	20	34	26	55	40	70	50	80	60	85	68
1/2	13	38	31	75	55	95	70	110	80	113	90
1/2	20	52	42	90	65	100	80	120	90	126	100
9/16	12	52	42	110	80	135	100	150	110	163	130
9/16	18	71	57	120	90	150	110	170	130	181	144
5/8	11	98	78	150	110	140	140	220	170	230	184
3/4	10	157	121	260	200	320	240	380	280	400	320
3/4	16	180	133	300	220	360	280	420	320	440	350
7/8	9	210	160	430	320	520	400	600	460	640	510
7/8	14	230	177	470	360	580	440	660	500	700	560
1	8	320	240	640	480	800	600	900	680	980	780
1	12	350	265	710	530	860	666	990	740	1060	845

TABLE 3F: VARIOUS FUNCTION FACTORY SETTING RANGES

FUNCTION	FACTORY SETTING
Motor No-Load Hi RPM	3100
Air Cut-in pressure	100
Air Cut-out pressure	125
AC generator Hz (no load)	61
AC generator 240 plug (no load)	243
AC generator 120 plug (no load)	122
AC generator 120 plug (no load)	122
Welder OCV Voltage	70
Welder Max Amperage	300
Welder Max CV Voltage	40
Welder Min CV Voltage	15
Welder 12V charge voltage	14
Welder 12V boost voltage	16
Welder 24V boost voltage	30

TABLE 3G: GENUINE VANGUARD™ OIL CHARACTERISTICS

Viscosity	178 SUS at 100°F (38°C)
Flashpoint	495°F (257°C)
Pour point	-49°F (-45°C)
Contains	Rust and Oxidation Inhibitors
Contains	Detergents

TABLE 3H: MACHINE PACKAGE DIMENSIONS

For complete machine package dimensions, consult *Section 4.5 Installation and Dimensions Diagram (Part 1 of 2)*, and *Section 4.6 Installation and Dimensions Diagram (Part 2 of 2)*.

BLANK PAGE

SECTION 4: INSTALLATION

4.1 MACHINE PACKAGE RECEIPT/ INSPECTION

Upon receipt of the machine package, inspect the exterior of the shipping crate for signs of shipping/transit damage. Any damage should be reported immediately to the shipping company. Open the lid and inspect the component parts and supports to ensure that there have been no internal movements of assemblies or components which may have caused damage. To install the Air N Arc® 300 Series All-In-One Power System®, refer to the following sections, presented in order of assembly:

System Component or Part Group Task	Manual Section	Location
Machine Package Receipt/Inspection	4.1	page 37
Air N Arc 300 Series All-In-One Machine Package Preparation	4.2	page 38
General Overview of Installation	4.3	page 38
Preparing the Vehicle Service Body	4.4	page 38
Mounting the Machine	4.5	page 42
Grounding the Machine	4.6	page 45
Installing the Control Trunk Line	4.7	page 45
Installing the (Optional) Remote Control Panel	4.8	page 45
Installing the Remote Air Tank	4.9	page 45
Post-Set Up Initial Test Function	4.10	page 46
Compressor Flow Schematic Diagram	4.11	page 48
Installation and Dimensions Diagram	4.12 (1 of 2)	page 49
Installation and Dimensions Diagram	4.12 (2 of 2)	page 50

⚠ DANGER

Grounding must consist of a minimum 2 gauge wire between the instrument panel, the machine, and the truck chassis.

⚠ DANGER

DO NOT install in enclosed spaces.

⚠ WARNING

ELECTRICAL HAZARD! Be sure the battery is disconnected before starting the installation.

NOTE

Contact Vanair® at
(219) 879-5100 / (800) 526-8817
Service Fax: (219) 879-5335
www.vanair.com
to report missing items, incorrect part numbers, or other discrepancies.

NOTE

Install electrical components (circuit breakers, pressure switches, toggle switches, etc.) in locations where exposure to water or moisture will be most minimized.

NOTE

In order to prevent accidental damage to vehicle components (fuel tanks, lines, brake lines, wiring harnesses), note their location before drilling any holes.

NOTE

<p>Read this manual before installing, operating or servicing this equipment. Failure to comply with the operation and maintenance instructions in this manual WILL VOID THE EQUIPMENT WARRANTY.</p>

4.2 AIR N ARC® 300 SERIES ALL-IN-ONE® MACHINE PACKAGE PREPARATION

Refer to **Section 4.10** for the proper installation and dimensions diagram (note that the section contains two parts/diagrams), and the following instructions.

1. Remove crate lid and packing.
2. Inspect the machine and control panel for shipping damage.

Should any damage be discovered during package inspection, contact the shipping company immediately.

4.3 GENERAL OVERVIEW OF INSTALLATION

NOTE
<p>Although much of the information given in this installation section is detailed, these guidelines should be considered as referential material only, due to the diverse possibilities of the end user's vehicle make, model and year, and the unit model specifications.</p>

When determining the factors involved with the installation of the Air N Arc 300 Series machine on a vehicle, use this manual in tandem with the vehicle's own manual to get a feel for how the machine and its systems need to integrate with the vehicle's layout and systems.

Depending upon the customer-specified machine order, an installation may include all or part of the following major task list breakdown:

- Machine mounting
- Air tank mounting (skid-mounted model)
- Instrument panel mounting
- Connecting service and auxiliary lines, and electronics

4.4 PREPARING THE VEHICLE SERVICE BODY

System Component or Part Group Task	Manual Section	Location
Preparing the Vehicle Service Body	4.4	page 38
<i>continued on next page</i>		

System Component or Part Group Task	Manual Section	Location
Machine Clearance Allowance	4.4.1	page 40
Determining Proper Ventilation Requirements	4.4.2	page 40
Roof Requirements (If Applicable)	4.4.3	page 40

When determining the best location to mount the Air N Arc 300 Series machine and also its remote components, the following criteria must first be taken under consideration:

- Machine package dimensions: Refer to **Figure 4-10** for dimension measurements, including auxiliary component dimensions, where applicable..
- Minimal clearance allowances for the purpose of cooling, ventilating and machine access (in addition to each dimension of the machine).
- Free-flow allowance of fresh circulating air for cooling purposes.
- Remote component locations' proximity to machine (air tank, instrument panel, roof [optional]).
- Hindrance to any access, or operation of, other standard or mounted vehicle system(s), including any underdeck, or chasis wiring, piping, etc.,
- Clear pathways for route lines and wires, which are free of sharp edges, sharp angles and heat contact (if applicable).
- Service output location.

Additional service body preparation includes the following:

- Ensure that the mounting surface for the machine, as well as any remote component(s), are level, cleared of debris, and able to support the machine and/or its component(s) after being mounted.
- For particular load-bearing locations, if necessary, additional support may be



CAUTION

When determining the proper machine mounting location on the vehicle body, always consider the location's effect on safe operation of the machine. Use the guidelines given in Section 1, Safety to verify an optimal, safe location before permanently mounting the machine.

needed to assure stability of the machine once it is mounted.

 CAUTION
<p>Note that improperly-mounted equipment may have the potential to cause harm, and possibly cause damage or undo stress on the equipment.</p>

4.4.1 MACHINE CLEARANCE ALLOWANCE

Refer to **Figure 4-1**. Allowances must be made for proper distance surrounding the machine (six inches [6"] minimum: front and back). Most importantly a fresh, cool and unhindered air supply must be allowed at the air intake side of machine. In addition, clearance space surrounding the machine is needed for purposes of maintenance and control.

If desired mounting place needs to be pre-measured, the additional *minimum* of six inches [6"] of surrounding clearance space amounts to the machine location dimensions given in **Table 4A - Allowable Machine Parameter Measurements**.

4.4.2 DETERMINING PROPER VENTILATION REQUIREMENTS

The Air N Arc® All-In-One Power System® 300 Series machine is air cooled; adequate provision for supply of cool air to the engine, compressor and generator is required. The air requirements for proper ventilation need to be considered when preparing to install the Air N Arc 300 Series machine:

IMPORTANT
<p>The minimum vent air opening area for the Air N Arc 300 Series machine is:</p> <p style="text-align: center;"><i>230 in² cold air in</i></p> <p style="text-align: center;"><i>260 in² hot air out</i></p>

4.4.3 ROOF REQUIREMENTS (IF APPLICABLE)

If a roof above the machine is required it must be retractable to allow for proper air circulation, as noted in **Section 4.4.2, Determining Proper Ventilation Requirements**.

NOTE
<p>Roof should have a switch installed that will prevent machine startup when the roof is down.</p>

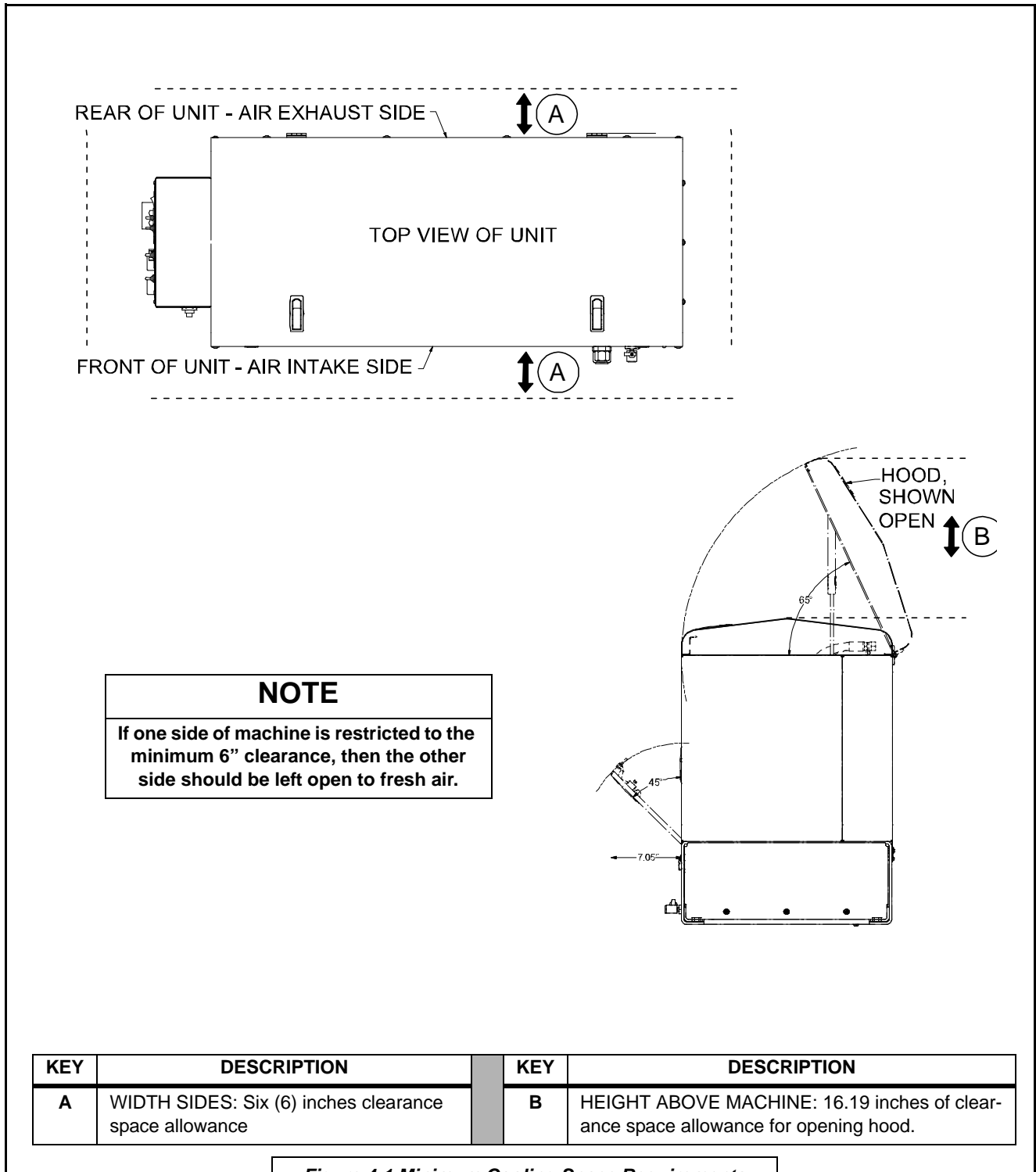

Figure 4-1 Minimum Cooling Space Requirements

4.5 MOUNTING THE MACHINE

Refer to **Figure 4-1**. Once all of the factors listed in **Section 4.3** have been considered, and the machine placement location has been resolved, the machine must be fully unpackaged from its crate mounting.

System Component or Part Group Task	Manual Section	Location
Mounting the Machine	4.5	page 42
Separating the Machine From the Shipping Crate Mounting	4.5.1	page 43
Marking the Machine Mounting Location	4.5.2	page 43
Stabilizing Precautions for Machine Mounting	4.5.3	page 44

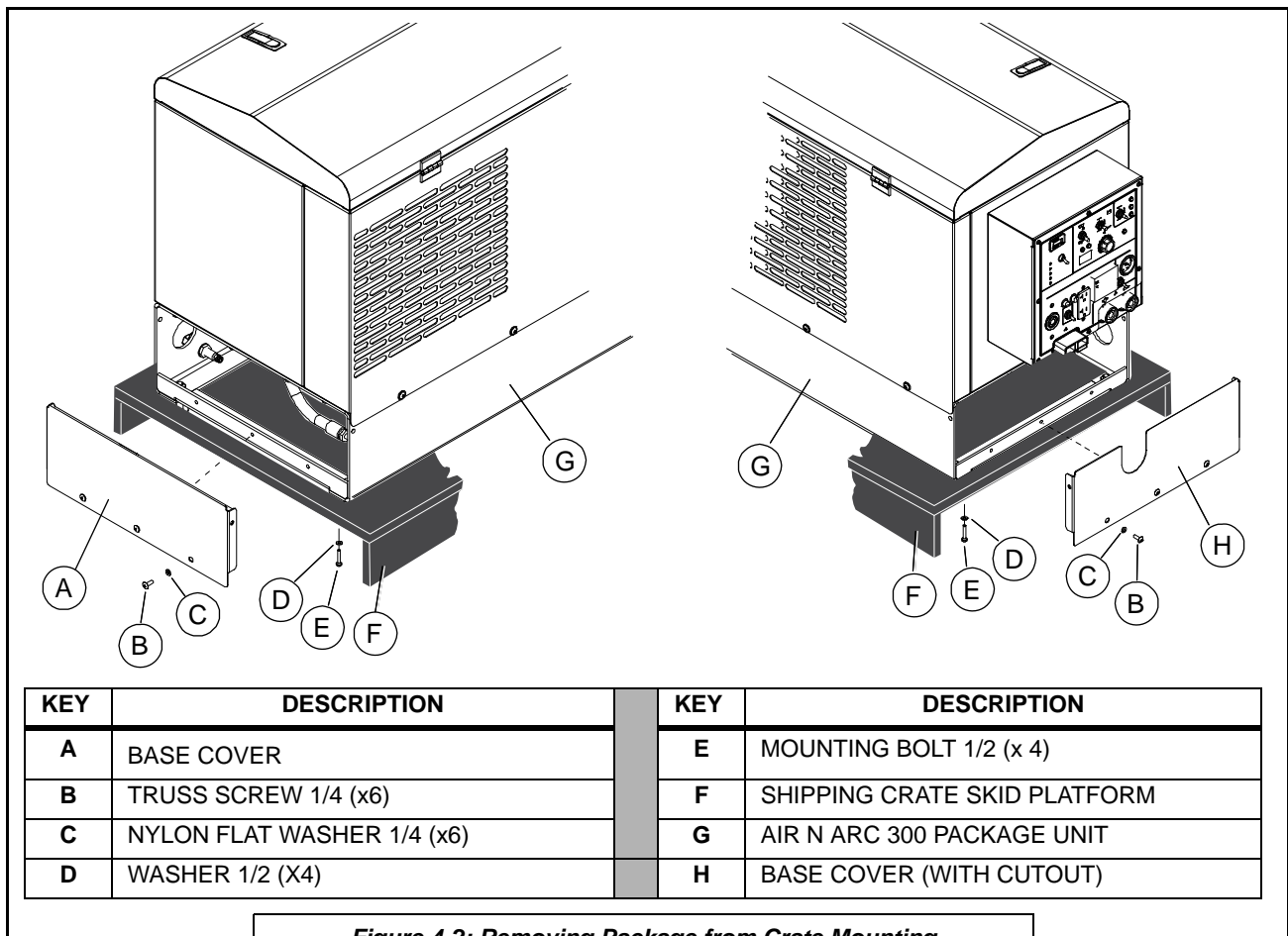

Figure 4-2: Removing Package from Crate Mounting

4.5.1 SEPARATING THE MACHINE FROM THE CRATE MOUNTING

Refer to **Figure 4-2** and the following instructions.

1. Remove the nuts, lock washers, washers and mounting bolts used to fasten the machine to the shipping crate skid platform.
2. Reserve the mounting hardware used to mount the machine to the shipping crate. This hardware can be reused when mounting the machine to the vehicle. However, depending upon the thickness of the vehicle mounting surface, and the addition of vibration isolators (**Section 4.5.3**), the mounting bolts may not be long enough to secure the machine package. The minimum thread clearance is 2-1/2" threads showing above the nut, with the machine fastened in place (**Figure 4-3**).

4.5.2 MARKING THE MACHINE MOUNTING LOCATION

1. Using a proper hoist, lift and place the unit into a preliminary position on the service body of the vehicle so that access is easily attained, the control trunk line and all other connections will reach the unit, and there is enough space surrounding the mounting area for cooling purposes. Refer to **Figure 4-4** for lifting bail location.

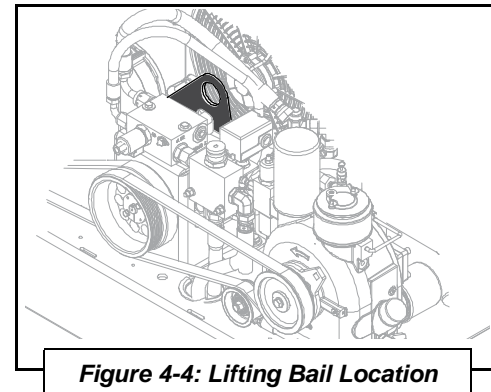
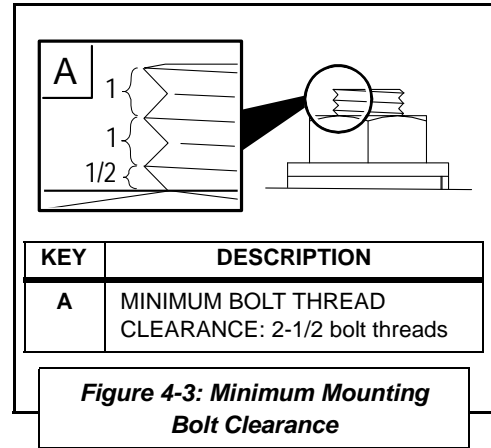

	CAUTION
<p>Lift the machine package in accordance within the safety guidelines given in Section 1.7.1, Falling Unit Can Cause Injury.</p>	

NOTE
<p>When the machine is to be lifted via a crane or hoist, always use the lifting bail to lift the machine. Using any other bail point on the machine may cause damage.</p>

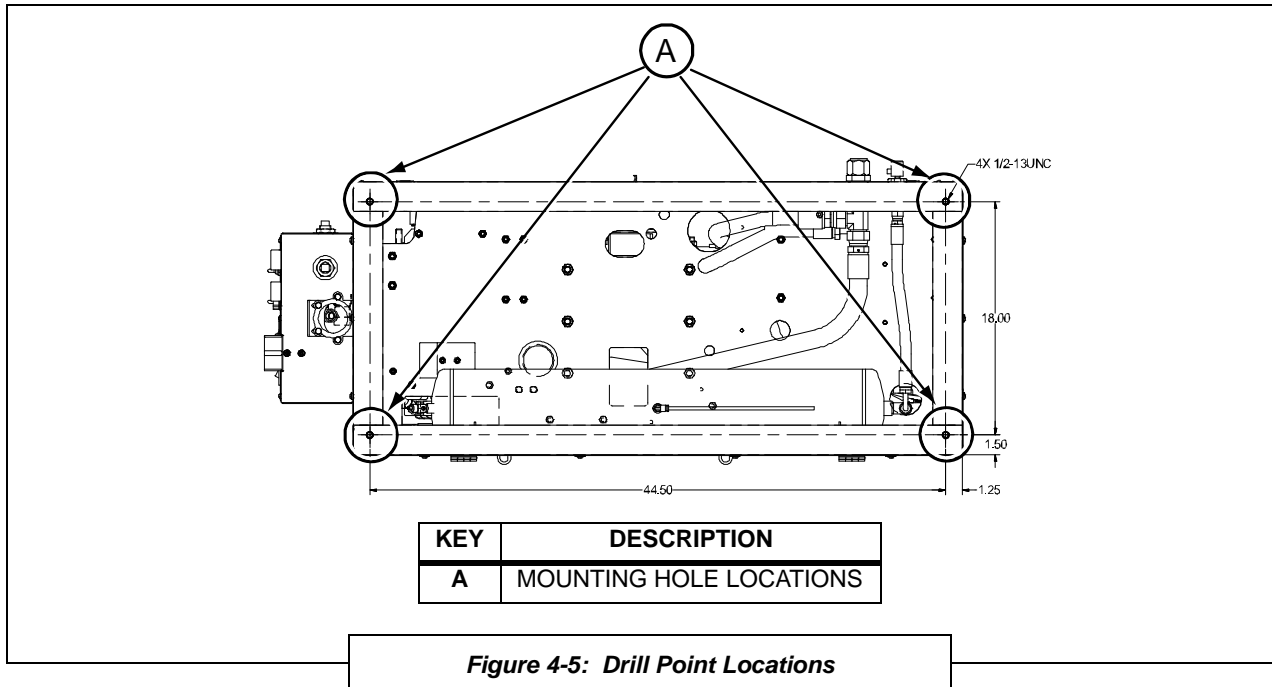

Figure 4-5: Drill Point Locations

IMPORTANT

Vehicle mounting surface must be level, and may need to be augmented for support and/or stability, if necessary.

2. Refer to **Figure 4-5**. Using a scribing tool or pen, place a mark through all of both mounting holes [A] on the service body's mounting surface. There will be a *minimum* of four (4) holes that will need to be indicated (two to three for each bracket).
3. Ensure that all proper machine clearances will be maintained. Then temporarily move the machine so that the service body floor can be drilled. Drill four (4) 9/16" mounting holes in the service body floor at the scribed markings made in step #4.

NOTE

Do not bolt and torque machine into place until all preparation tasks as described in **Sections 4.4 through 4.12** have been achieved.

4.5.3 STABILIZING PRECAUTIONS FOR MACHINE MOUNTING

Refer to **Figure 4-6**. Machine should be mounted to vehicle using a minimum of four (4) isolators. Isolators

absorb vibration and allow for a complete sealing of the machine to the mounting surface. For ordering details, consult **Appendix A, Section A.5 (#20)**.

4.6 GROUNDING THE MACHINE

The machine frame must be grounded to the truck chassis using a minimum 2 gauge wire. Connect the ground cable to the unit battery.

4.7 INSTALLING THE CONTROL TRUNK LINE

If the machine location calls for an access hole to be drilled in the vehicle body, the hole size must accommodate the 1/2" air line. When drilling the access hole, ensure that there is no hindrance to any access, or operation of, other standard or mounted vehicle system(s), including any under deck or accessible wiring, piping, etc.

Once the access hole is drilled, place a rubber or suitably-protective grommet around the circumference of the hole to protect the air line from being cut or worn.

1. Route the control trunk-line through the grommetted opening.
2. Connect the 1/2" air line via the JIC fitting on the end of the air tank, and connect and secure the weatherproof connectors. The plugs are all differentiated to ensure that they cannot be mis-connected.

4.8 INSTALLING THE (OPTIONAL) REMOTE CONTROL PANEL

Install the (optional) remote control panel at the desired location on the service body and route the control trunk line to the location where the unit will mount. Ensure that all sharp edges that the trunk-line contacts are shielded or grommetted, and that there are no excessively sharp bends in the trunk-line. Ensure the trunk line does not come in contact with exhaust parts.

4.9 INSTALLING THE REMOTE AIR TANK

The air tank, and subsequent piping, must have a minimum rating of **200 psi**; if tank is larger than six inches (6") OD, it must be ASME rated. To determine the

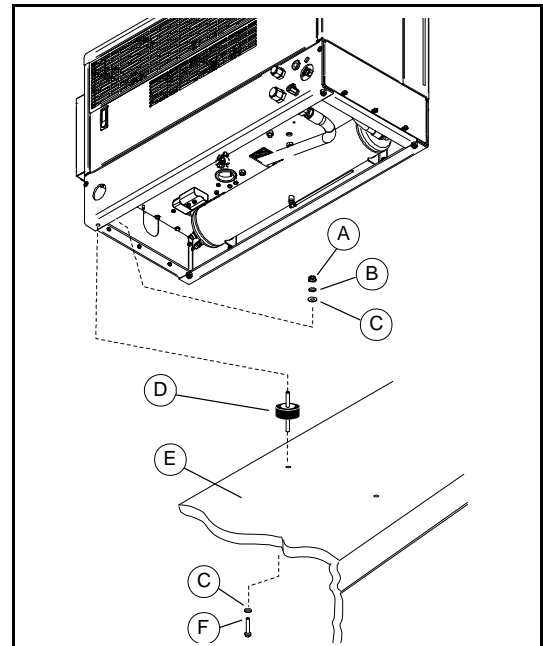

KEY	DESCRIPTION
A	MOUNTING NUT 1/2" (x 4) NYLOCK ^I
B	LOCK WASHER 1/2" (x 4)
C	WASHER 1/2" (x 8 qty)
D	VIBRATION ISOLATOR ^{II}
E	MOUNTING SURFACE
F	MOUNTING BOLT 1/2" (x 4)

^I Nylock nuts should be used to prevent the mounting hardware from loosening, due to vibration from travelling, operating, etc.

^{II} A minimum of four (4) vibration isolators are required (Vanair no. PR271935).

Some or all of the mounting hardware used to mount the machine to the shipping crate may be reused when mounting the machine to the vehicle. However, depending upon the thickness of the vehicle mounting surface, or if using vibration isolators, the mounting bolts or vibration studs may not be long enough to secure a proper fastening. Be aware that a minimum thread clearance of 2-1/2" threads showing above the nut, with the machine fastened in place, is required (see Figure 4-3).

Figure 4-6: Mounting Isolators

NOTE

Mounting brackets are available to space panel off from truck body (Figure 4-7). Contact Vanair® for details.

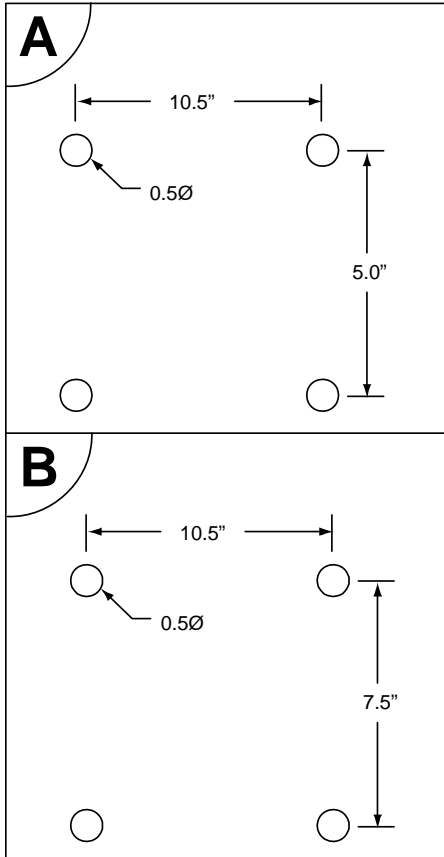

KEY	DESCRIPTION
A	MOUNTING PATTERN WITH SPACER (P/N A16738P)
B	MOUNTING PATTERN WITHOUT SPACER

Figure 4-7: Remote Panel Mounting Pattern (with and without Spacer)

location of a remote-mounted air tank, consider the following:

- Air system piping relation to the 300 Series machine.
- Hindrance to any access, or operation of, other standard or mounted vehicle system(s), including any under deck, or accessible wiring, piping, etc.
- Service output location.

To prepare and install the remote air tank follow these guidelines:

TOOLS/ITEMS NEEDED	REPLACEMENT PART(S)
Air Tank and Mounting Hardware [‡]	
Relief Valve (200 psi) - supplied	CO450008
Discharge Piping (see below)	
Wrenches	

[‡] NOTE: If tank is larger than 6"OD, it must be ASME rated.

NOTE

When determining the location of the air tank, keep in mind that the drain valve will need to be accessed on a frequent (daily) basis.

For compressor discharge piping, use a 3/4" minimum, S-TW Series hose (that meets SAE 100R14A), extruded PTFE tube with stainless steel single wire braid. The working pressure and temperature ratings should be: 200 psi air @ 300°F (similar to PA87939).

NOTE

Ensure that the lines do not make contact with sharp edges, moving parts or exhaust heat (consult Appendix A, Section A.6, Hose Installation Guide for assistance in running hose lines).

4.10 POST-SET UP INITIAL TEST FUNCTION

Before attempting the post-set up initial test function, review all of the tasks laid forth in Sections 4.4 through

4.7. Use the following check list to aid in determining that all functions are ready for a test run.

PRE-TEST FUNCTION CHECK LIST		
TASK	SECTION REFERENCE	COMPLETED
Preparing the Vehicle Service Body	4.4	<input type="checkbox"/>
Mounting the Machine	4.5	<input type="checkbox"/>
Grounding the Machine	4.6	<input type="checkbox"/>
Installing the Remote Air Tank (Skid-Mount Model)	4.9	<input type="checkbox"/>

1. With the vehicle located on a level surface check all fluid levels (**NOTE:** vehicle should be on a level surface in order to get accurate fluid level checks). If fluid refills are needed refer to **Section 6.5.2** for compressor oil maintenance.
2. If machine is not in its mounting position, move the unit into its final location, while positioning the control trunk line and all other connections.
3. Bolt the machine down with four ½" bolts or vibration isolators inserted up from the bottom through the four mounting bolt holes of the base frame (refer to **Section 4.5.3** and **Figure 4-6**). See **Section 4.10, Parts 1 and 2**, for base mounting pattern, etc.

Note that, with the addition of the vehicle mounting surface and the isolator thickness, the bolt must have a minimum clearance of 2-1/2" threads above the fastening nut after final tightening (see **Figure 4-3**). Should the mounting bolts from the shipping crate prove to be too short, replace them with proper length bolts.

4. Start the unit and fully test all functions (refer to **Section 5, Operation**). Warm the unit to full operating temperature. After the unit has cooled, check all fluid levels and add as needed.

4.11 COMPRESSOR FLOW SCHEMATIC DIAGRAM

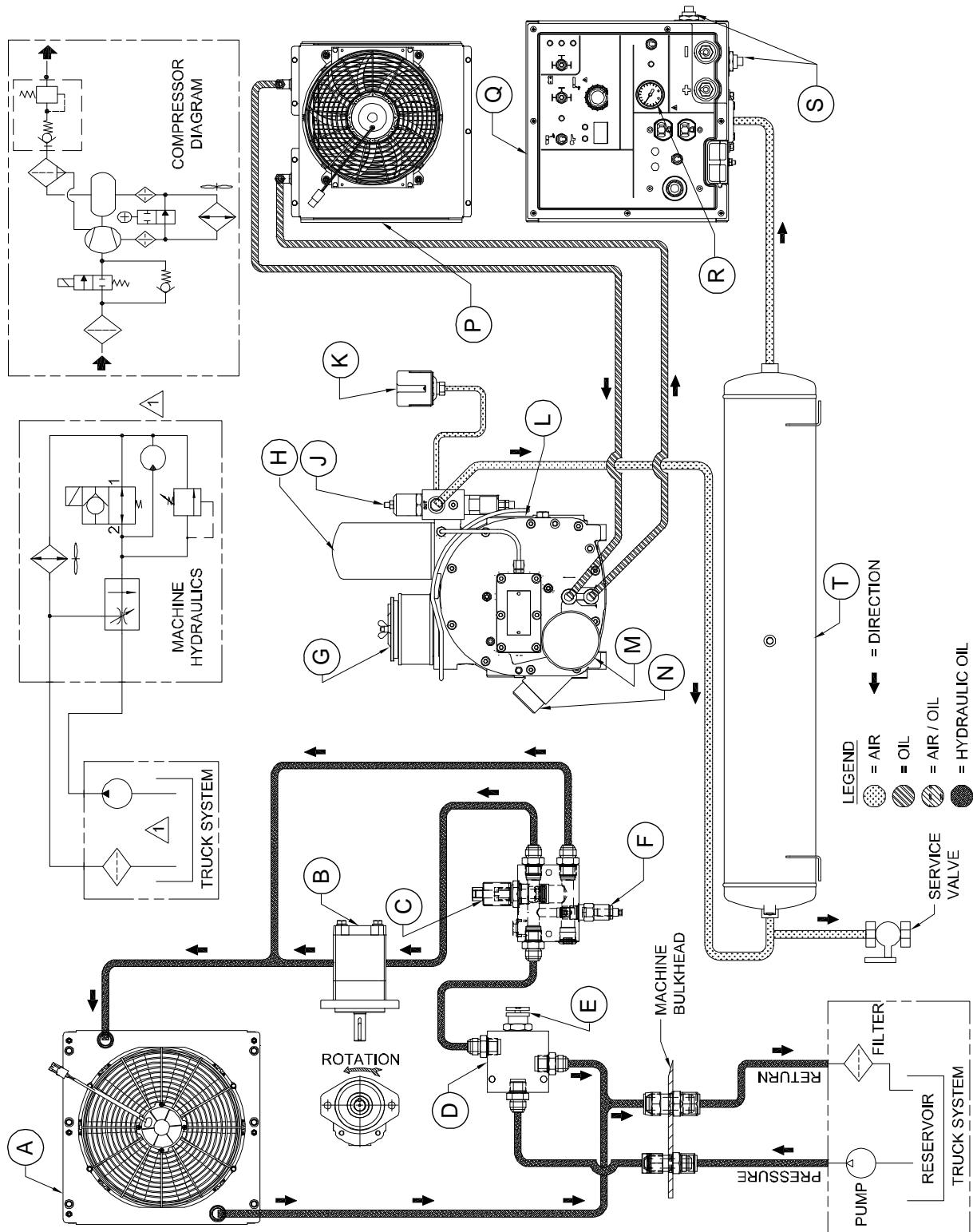

271384_r1

4.12 INSTALLATION AND DIMENSIONS DIAGRAM (PART 1 OF 2)

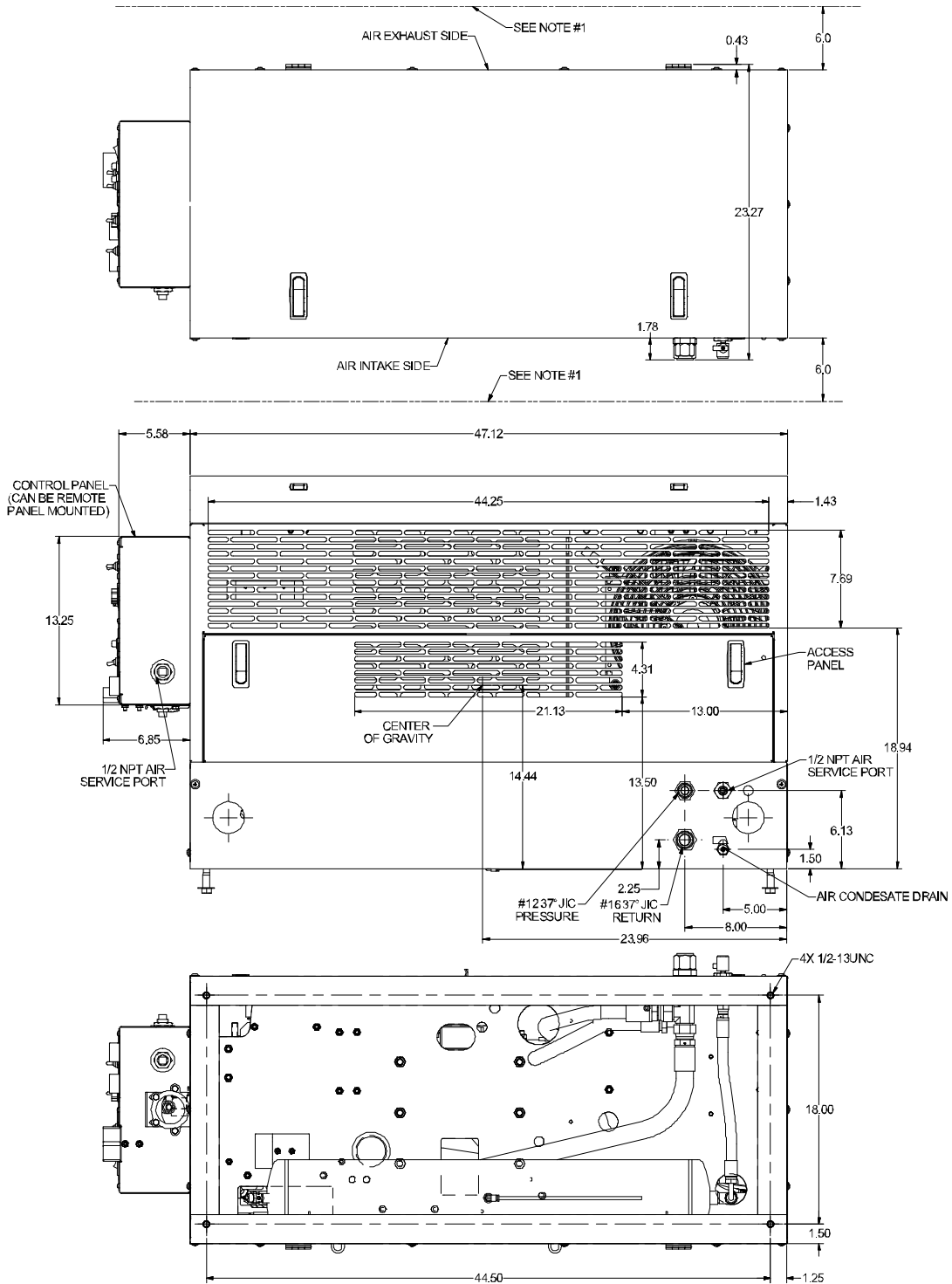

050735ID_1of2_r0

4.12 INSTALLATION AND DIMENSIONS DIAGRAM (PART 2 OF 2)

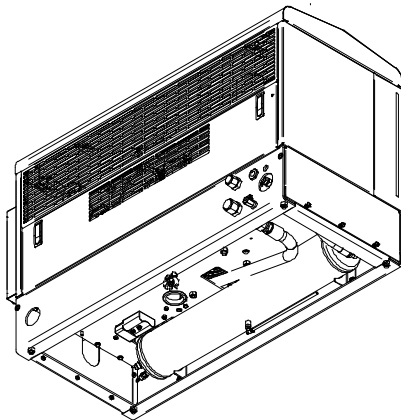
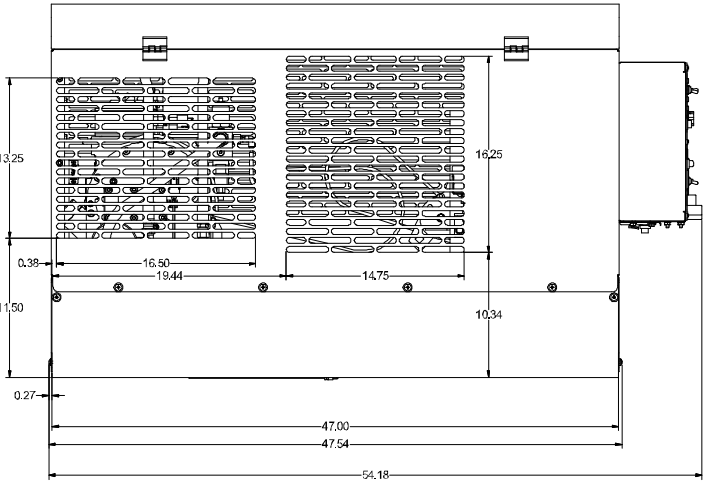
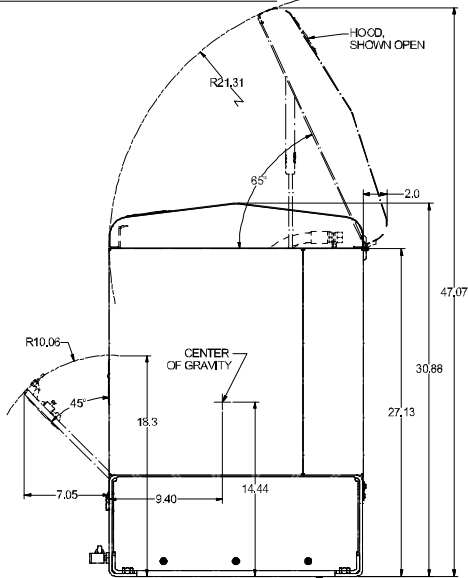
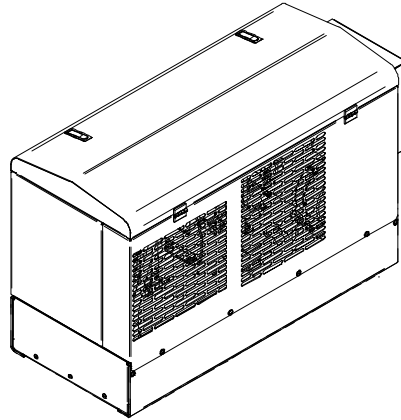
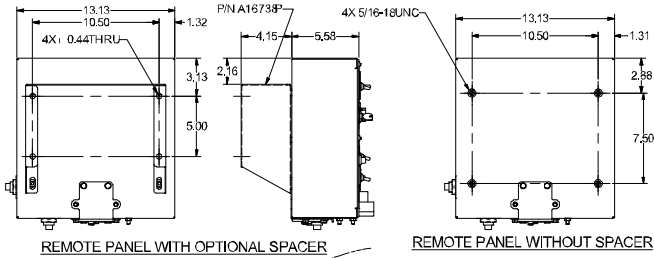

050735ID_2of2_r0

BLANK PAGE

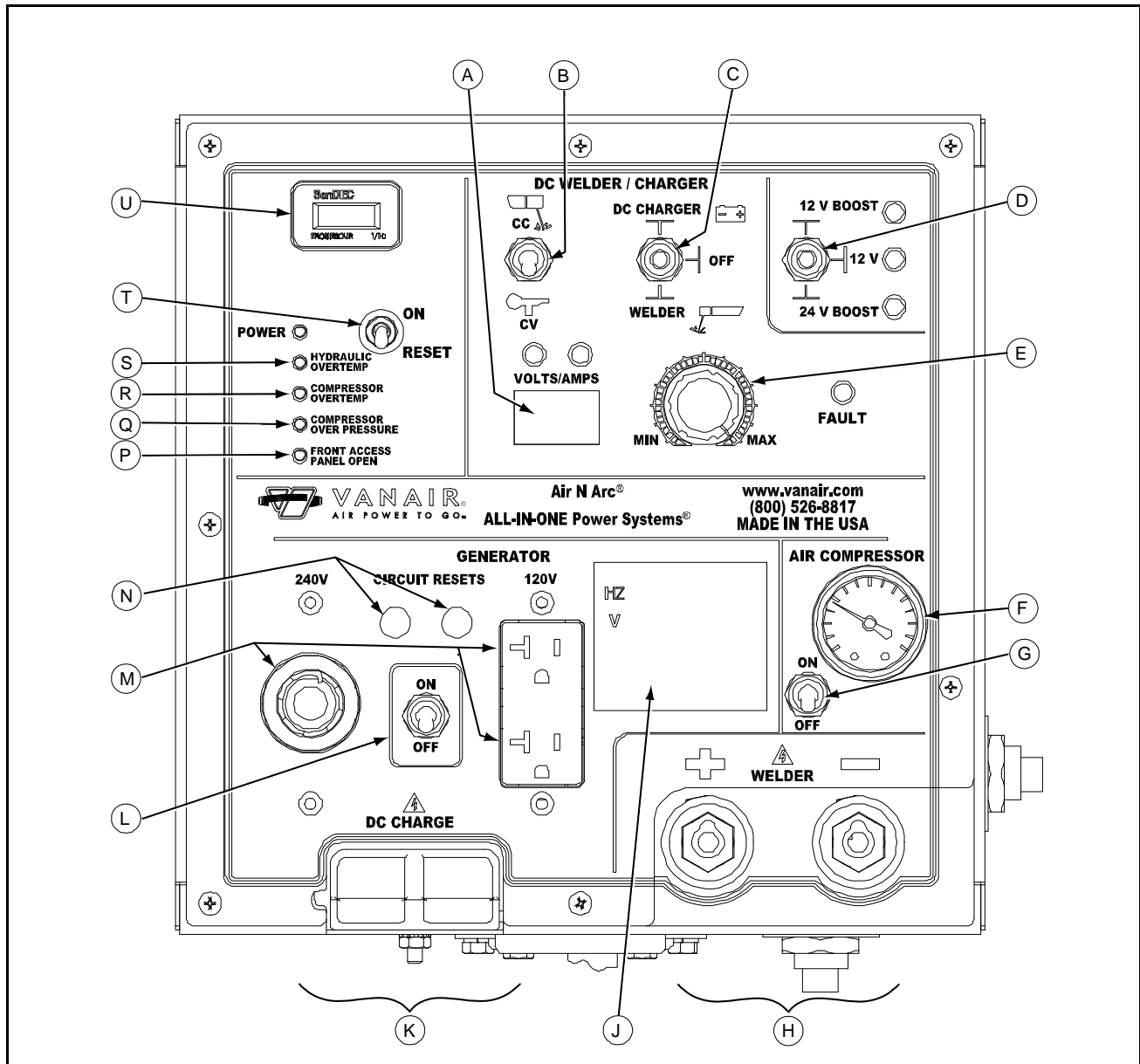

KEY	DESCRIPTION	KEY	DESCRIPTION
A	DC VOLTS/AMPS METER (2.6.1)	L	AC GENERATOR CONTROL ON/OFF SWITCH (2.6.10)
B	WELDER CC/CV TOGGLE SWITCH (2.6.2)	M	AC VOLTAGE OUTLETS (2.6.11)
C	DC CHARGER/WELDER TOGGLE SWITCH (2.6.2)	N	AC CIRCUIT BREAKER TRIP/RESET BUTTONS (2.6.12)
D	DC CHARGER MODE TOGGLE SWITCH (2.6.3)	P	FRONT ACCESS PANEL OPEN LAMP (2.6.13) SHUT-DOWN
E	VOLTS/AMPS MANUAL ADJUSTMENT DIAL (2.6.4)	Q	COMPRESSOR OVER PRESSURE LAMP (2.6.14) SHUTDOWN
F	COMPRESSOR AIR PRESSURE GAUGE (2.6.5)	R	COMPRESSOR OVERTEMP LAMP (2.6.15) SHUT-DOWN
G	COMPRESSOR ON/OFF TOGGLE SWITCH (2.6.6)	S	HYDRAULIC OVERTEMP LAMP (2.6.16) SHUTDOWN
H	WELDER LEAD CONNECTION (2.6.7)	T	MACHINE ACTIVE/RESET SWITCH (2.6.17)
J	AC HZ/VOLTAGE METER (2.6.8)	U	HOUR METER (2.6.18)
K	BATTERYCABLE RECEPTACLE (2.6.9)		

Figure 5-1: Instrument Panel Functions

SECTION 5: OPERATION

5.1 GENERAL INFORMATION

The Air N Arc 300 All-In-One Power System has a comprehensive array of controls and indicators for each function of the power system. Understanding the correct operation of the 300 Series system will help you to understand and recognize when the system is operating optimally. The information in the Operation Section will help the operator to recognize and interpret the readings, which will call for service or indicate the beginning of a malfunction.

NOTE

<p>Before starting the Vanair® Air N Arc 300 All-In-One Power System, read this section thoroughly and familiarize yourself with the controls and indicators - their purpose, location and use.</p>

System Operation Group	Manual Section	Location
Machine Start-up and Shutdown Procedure	5.2	page 54
Machine Start-up	5.2.1	page 54
Machine Shutdown	5.2.2	page 55
Motor Throttle Control Functions	5.3	page 56
Operating the Welder	5.4	page 56
Welder Operating Procedure	5.4.1	page 57
CC (Constant Current) Mode	5.4.1.1	page 57
CV (Constant Voltage) Mode - Using a Voltage Sensing Suitcase Feeder	5.4.1.2	page 59
CV (Constant Voltage) Mode - Using a Spool Gun	5.4.1.3	page 59
Operating the Generator	5.5	page 60
Operating the Air Compressor	5.6	page 61

Continued on next page

 DANGER
<p>Grounding must consist of a minimum 2 gauge wire between the instrument panel, the machine, and the truck chassis.</p>

 WARNING
<p>Before performing maintenance or repair operations on the compressor, ensure that all power has been removed by disconnecting battery cables, to prevent accidental start-up.</p>

 WARNING
<p>Before starting, performing maintenance, or replacing parts, relieve the entire system pressure by opening the air tank drain/vent valve, which will vent all pressure to the atmosphere.</p>
<p>Refer to <i>Figure 5-2</i>. Open fill cap SLOWLY (contents under pressure) to make sure all pressure has been relieved.</p>

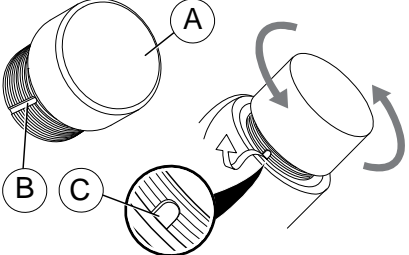

KEY	DESCRIPTION
A	RED COMPRESSOR FILL CAP
B	FILL CAP BLEED VENT GROOVE
C	Open/crack cap slightly to allow bleed vent to relieve pressure

Figure 5-2: Pressure Relief

WARNING

Follow all applicable safety recommendations as outlined in *Section 1: Safety of this manual.*

NOTE

If any of the compressor, generator or welder switches are set to ON prior to starting, the machine will start at full speed.

IMPORTANT

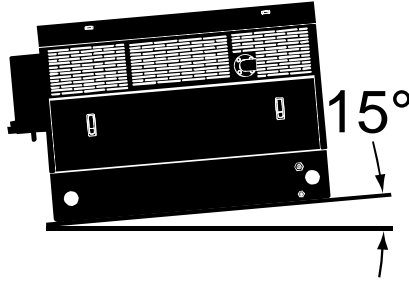

All machine package maximum operation angles of tilt are fifteen degrees (15°).

WARNING

Machine hood and front access panel must be closed before starting. Interlock switch will not allow starting with panel open.

System Operation Group	Manual Section	Location
Operating the Battery/Boost Charger	5.7	page 62
Connection - Disconnection Sequence and Operation	5.7.1	page 62
Extreme Condition Operation	5.8	page 63
Cold Weather Operation	5.8.1	page 64
General Operation	5.8.1.1	page 64
Machine Operation	5.8.1.2	page 64
High Temperature Operation	5.8.2	page 65
Machine Operation	5.8.2.1	page 65
High Dust Content Operation	5.8.3	page 65
Machine Operation	5.8.3.1	page 65
High Altitude Operation	5.8.4	page 65

5.2 MACHINE START-UP AND SHUTDOWN PROCEDURE

NOTE

If start-up and shut-down procedures are not followed, damage to the system and its components may occur.

Consult *Figure 5-1: Instrument Panel Functions* for operating procedures detailed in this section.

System Operation Group	Manual Section	Location
Machine Start-up and Shutdown Procedure	5.2	page 54
Motor Start-up	5.2.1	page 54
Machine Shutdown	5.2.2	page 55

5.2.1 MACHINE START-UP

Consult *Figure 5-3*, and the following steps:

1. Check to make sure all switches [A] (Welder, Generator, and Compressor) are in the **OFF** position prior to starting.
2. Turn the machine control switch to the **ON** position [B].
3. Start truck.
4. Engage PTO.
5. Let engine run at idle for 3-5 minutes to allow for warm up sequence.

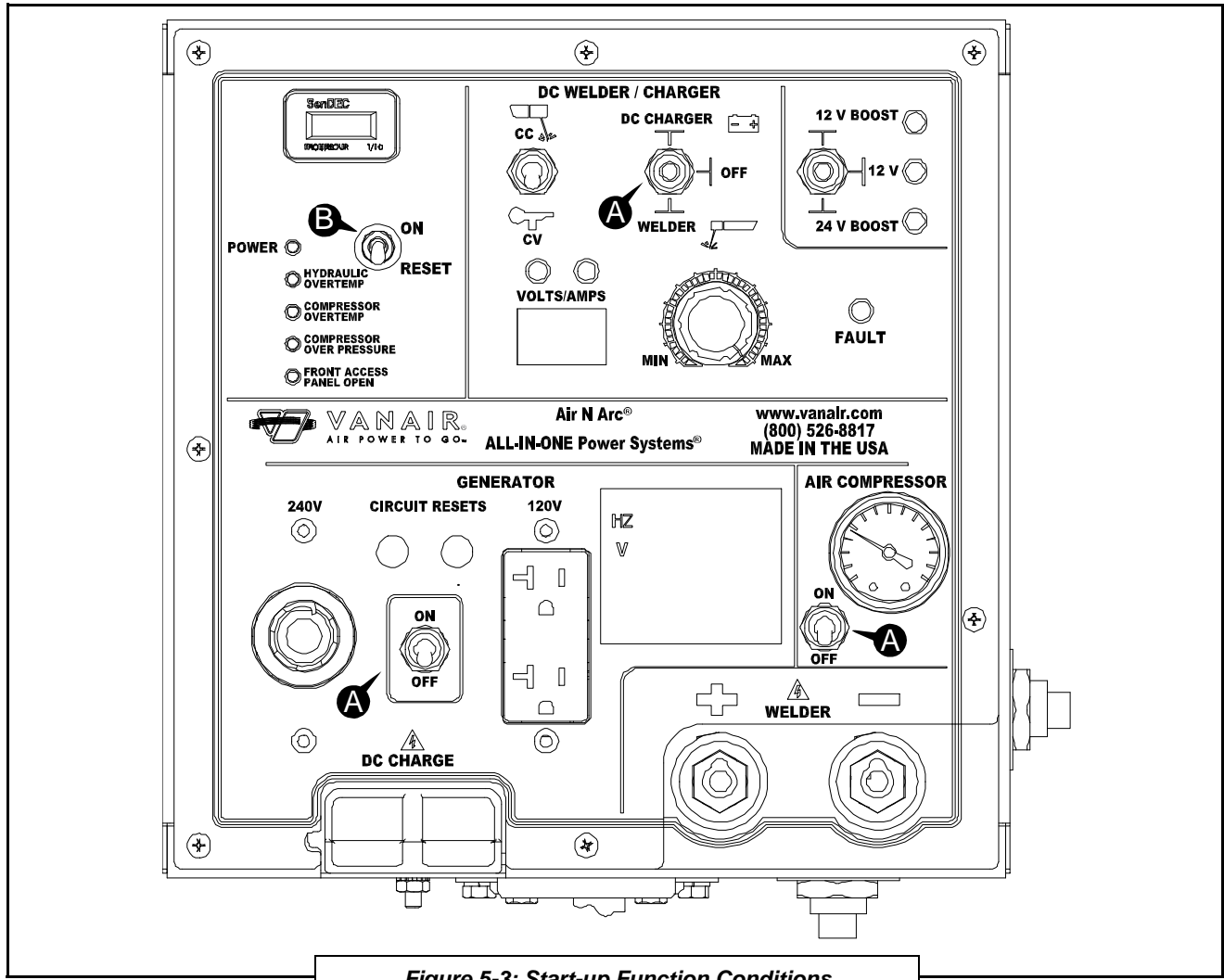

Figure 5-3: Start-up Function Conditions

5.2.2 MACHINE SHUTDOWN

Consult **Figure 5-1**. To shut the machine off at any time, turn the machine control switch to the **OFF** position. However, this method is best reserved for emergency shutdown situations only. Vanair® recommends that the following procedure is used for routine shutdowns in order to keep the system in optimal condition, and minimize undue stress that may occur during the next start up session if some of the machine conditions were left in working mode(s) or had auxiliary power draws left intact (such as a tool receptacle left plugged into the generator, etc.).

To prepare the machine for shutdown:

NOTE

Refer to Truck Operator’s Manual for additional information pertaining to the starting of the truck.

 **CAUTION**

Compressors and motors generate heat and create hot surfaces. Use caution when operating and servicing equipment. Some surfaces and components may be hot.

1. Shut off any tools or other items that are drawing power from the generator, or compressed air from the air tank.
2. Close all service valves.
3. Unplug any power cords that are plugged into the generator panel.
4. Turn the **Compressor, Generator** and **Welder** switches on the control panel to the **OFF** position.
5. Allow machine to bypass for 3-5 minutes to allow for a cool down sequence.
6. Turn the **motor Control Switch** to the **OFF** position.

5.3 MOTOR THROTTLE CONTROL FUNCTIONS

The motor function is controlled by three factors:

1. The position of the compressor switch.
2. The position of the welder switch on the unit control panel, and the use of the welder.
3. The position of the generator switch on the control panel.

Consult **Table 5A: Motor Throttle Control Function Conditions** to understand how the motor speed relates to the demand(s) of the machine system's output functions.

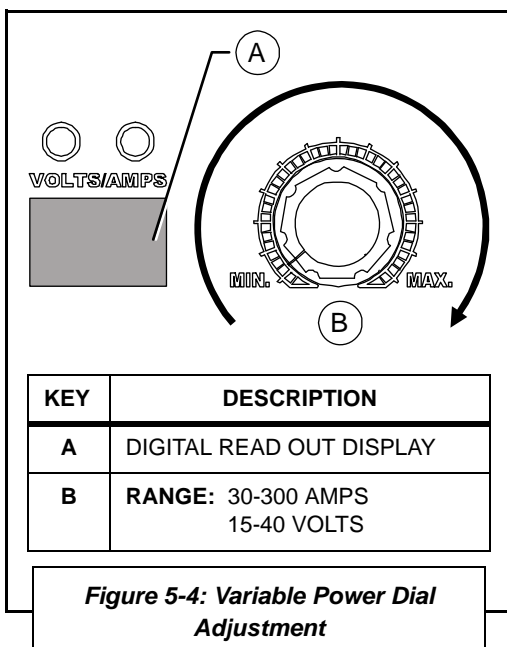

5.4 OPERATING THE WELDER

	WARNING
<p>Before attempting any welding procedure, the operator must be aware of general safety practices, and particularly those pertaining to welding, as found in <i>Section 1.4</i> of this manual.</p>	

Consult **Figure 5-4**. The **variable power dial** adjusts the welder amperage (30 to 300 amps), or voltage (15 to 40 volts) for the desired weld heat. Turning the power dial clockwise increases the amperage or voltage, and turning the power dial counterclockwise decreases the amperage or voltage. The power dial may be adjusted

while welding.

System Operation Group	Manual Section	Location
Operating the Welder	5.4	page 56
Welder Operating Procedure	5.4.1	page 57
CC (Constant Current) Mode	5.4.1.1	page 57
CV (Constant Voltage) Mode - Using a Voltage Sensing Suitcase Feeder	5.4.1.2	page 59
CV (Constant Voltage) Mode - Using a Spool Gun	5.4.1.3	page 59

NOTE

The amps/volts display will read the set value for five (5) seconds when the dial is adjusted, and the actual output value five (5) seconds after the dial has been adjusted.

5.4.1 WELDER OPERATING PROCEDURE

5.4.1.1 CC (CONSTANT CURRENT) MODE

CC (Constant Current) Mode is commonly referred to as - Stick Welding, Arc Welding, or Shielded Metal Arc Welding (SMAW)

1. With the motor shut off, insert the twist lock connections of the ground clamp and the electrode holder cables into the welder connection ports on the control panel. For Direct Current Electrode Positive (DCEP) connect the electrode holder to the positive (+) port, and the ground clamp to the negative (-) port. For Direct Current Electrode Negative (DCEN) connect the



WARNING

Do not rely on the thermal overload circuit breakers on the generator to protect personnel, power tools, or the generator. The thermal overload circuit breakers on the generator require time to overheat when the generator is operating in an overload condition — they do not provide instant protection against short circuiting or overload conditions. Always use GFCI protected extension cords and power strips when using the generator.

TABLE 5A: MOTOR THROTTLE CONTROL FUNCTION CONDITIONS^I

Compressor Switch	Generator Switch	Welder Switch	Motor Speed Condition Result
ON	OFF	OFF	Motor runs at full speed (3000 RPM).
OFF	OFF	OFF	Motor is bypassed (0 RPM), ready for application.
ON	OFF	ON	Welder can be activated by striking an arc, and Motor runs at full speed (3000 RPM), ready for application.
ON	ON	OFF	Motor runs at full speed (3000 RPM); generator is ready for use ^{II} .
ON	ON	ON	Full speed and all items available for use.

^IAny combination of the 300 Power System output functions (compressor, generator, welder) used simultaneously at capacity will have an adverse affect on operation.

^{II}Consult **Appendix A, Section A.3, Wattage Requirements for Common Receptacle Units** for a listing of wattage requirements of various implements.

NOTE
<p>If a longer welding lead is desired, optional 25 and 50 ft. lead segments may be purchased from Vanair Manufacturing, Inc. for a maximum lead length of 100 ft.</p>

- electrode holder to the negative (-) port, and the ground clamp to the positive (+) port.
- 2. Select the appropriate electrode for the material and process being performed. See **Table 5B: ELECTRODE SPECIFICATIONS** for selecting an electrode.
- 3. Place the ground clamp on the work piece and insert the appropriate welding rod into the electrode clamp.
- 4. On the control panel, place the CC/CV switch in CC mode. Place the DC Charger/Welder switch in welder mode.
- 5. Adjust the power dial to the appropriate amperage setting for the material and the electrode being used. (See **Table 5B: ELECTRODE SPECIFICATIONS** for electrode amperage ratings). At anytime during welding, the power dial may be adjusted to the desired amperage level.

NOTE
<p>For electrode striking technique, consult <i>Section A.7, Electrode Ignition Procedure</i> in Appendix A.</p>

- 6. When you strike the electrode against the material being welded, the motor will go to full speed and deliver the selected amperage through the electrode. Now you may begin to weld.
- 7. After a weld has been completed, and there is no contact between the electrode and the metal for 30 seconds, the motor will return to bypass.

TABLE 5B: ELECTRODE SPECIFICATIONS		
METAL THICKNESS	ELECTRODE SIZE	WELDING AMPERES
1/16-1/8	3/32	50-90
1/8-1/4	1/8	90-140
¼-3/8	5/32	120-180
3/8-1/2	3/16	150-230

5.4.1.2 CV (CONSTANT VOLTAGE) MODE - USING A VOLTAGE SENSING SUITCASE FEEDER

CV (Constant Voltage) Mode – commonly referred to as - Wire Welding, MIG welding, or Gas Metal Arc Welding (GMAW)

1. With the motor shut off, insert the twist lock connection of the ground clamp into the negative (-) welder connection port on the control panel. Insert the power lead segment from the suitcase feeder into the positive (+) welder connection port on the control panel.
2. Place the ground clamp from the suitcase feeder and the ground clamp from the Air N Arc 300 on the work piece.
3. On the control panel, place the DC Charger/ Welder switch in welder mode. Place the CC/CV switch in CV mode.
4. Adjust the power dial on the Air N Arc 300 to the appropriate voltage setting for the material being welded. Adjust the power dial on the suitcase feeder for the material being welded. At anytime during welding, the power dial may be adjusted to the desired voltage level.

5.4.1.3 CV (CONSTANT VOLTAGE) MODE - USING A SPOOL GUN

CV (Constant Voltage) Mode – commonly referred to as - Wire Welding, MIG welding, or Gas Metal Arc Welding (GMAW)

1. With the motor shut off, insert the twist lock connection of the ground clamp into the negative (-) welder connection port on the control panel. Insert the power lead segment from spool gun adapter into the positive (+) welder connection port on the control panel.
2. Place the ground clamp from the Air N Arc 300 on the work piece.
3. Start the motor (**See Section 5.2, Motor Start-up and Shutdown Procedure**).
4. On the control panel, place the DC Charger/ Welder switch in welder mode. Place the CC/CV switch in CV mode.
5. Adjust the power dial on the Air N Arc 300 to the appropriate voltage setting for the

NOTE

When using a spool gun, an adapter with contactor must be used. Please consult the spool gun manufacturer for appropriate adapter.

material being welded. At anytime during welding, the power dial may be adjusted to the desired voltage level.

What the numbers mean that are used to identify a stick welding electrode:

Using E6010 for an example...

The “E” indicates Electrode because some welding rods are not electrodes. The “60” in 6010 indicates the tensile strength in psi. 60,000 lbs.

The last two (2) digits indicate position and polarity along with what type flux. See **Table 5C: WELDING ROD TYPE, POLARITY AND FLUX CODES.**

5.5 OPERATING THE GENERATOR

IMPORTANT
<p>The Power System is designed to support a multi-function project. However, if the generator is operating at a high percentage of its rated capacity, and the welder and air compressor are also being used, the resulting drop in motor speed may produce a low voltage condition that will damage the generator and power tools being used.</p>

DIGIT	TYPE OF COATING	WELDING CURRENT
10	High cellulose sodium	DC+
11	High cellulose potassium	AC or DC+ or DC-
12	High titania sodium	AC or DC-
13	High titania potassium	AC or DC+
14	Iron powder titania	AC or DC- or DC+
15	Low hydrogen sodium	DC+
16	Low hydrogen potassium	AC or DC+
27	Iron powder iron oxide	AC or DC+ or DC-
18	Iron powder low hydrogen	AC or DC+
20	High iron oxide	AC or DC+ or DC-
22	High iron oxide	AC or DC-
24	Iron powder titania	AC or DC- or DC+
28	Low hydrogen potassium iron powder	AC or DC+

To operate the generator:

1. See **Section 5.2, Machine Start-Up Procedure.**
2. Turn the generator switch on the control panel to the **ON** position.

NOTE
<p>Only plug power cords into the generator receptacles AFTER the machine is running at full speed.</p> <p>Be careful not to overload the rated capacity of the generator - 6,800 watts (28 amps @ 240V) continuous.</p>

Combined output on all generator receptacles is limited to the total rated generator capacity. For example; if 1,500 watts (12.5 amps) is being drawn on the 120V duplex receptacle, only 3,700 watts (15.5 amps) is available at the 240V receptacle. Reference **Appendix A, Section A.3, Wattage Requirements for Common Receptacle Units**, for general information on the power requirements of common power tools, motors and extension cords. If the equipment is not listed in **Section A.3**, check the desired power tool, motor or extension cord manufacturer's specifications.

If the thermal overload circuit breakers on the generator are tripped due to an overload condition, press the white reset buttons on the generator panel to reset the breakers (**Figure 5-5**).

5.6 OPERATING THE AIR COMPRESSOR

The air compressor and the supply of high pressure air can be turned off. Whenever the pressure in the air tank drops below 100 psi or the set pressure.

 CAUTION
<p>Exposed high pressure air lines on the unit become hot during operation—keep everyone clear.</p>

When purchasing air tools or planning a project, the rated capacity of the compressor (40 CFM @ 175 psi) will need to be taken into consideration. See **Appendix A, Section A.4, Air Tool Air Consumption Chart**, for information on the compressed air requirements of common tools. If the equipment is not listed in **Section A.4**, check the desired power tool manufacturer's specifications.

 WARNING
<p>Do not rely on the thermal overload circuit breakers on the generator to protect personnel, power tools, or the generator. The thermal overload circuit breakers on the generator require time to overheat when the generator is operating in an overload condition — they do not provide instant protection against short circuiting or overload conditions. Always use GFCI protected extension cords and power strips when using the generator.</p>

 WARNING
<p>If one of the generator circuit breakers is tripped, the cause of the overload must be determined before the circuit breaker is reset and work is resumed.</p>

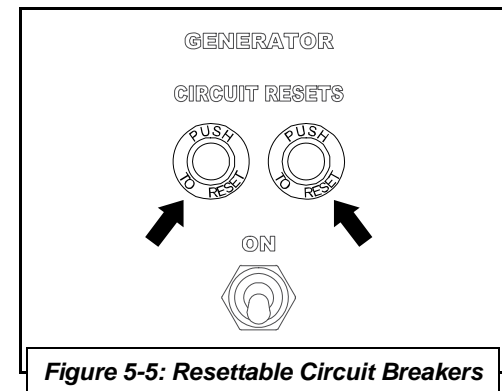

NOTE
<p>The Air N Arc 300 Power System unit features a high pressure, 175 psi air system. Check the maximum air pressure rating on the air tools being used. The operator is responsible for regulating the air pressure when necessary (See Section 6.6.14, Adjusting the Pressure Setting).</p>

NOTE
<p>The pressurized air system requires routine maintenance. See Section 6.3, Maintenance Schedule Table, to learn about important maintenance procedures.</p>

5.7 OPERATING THE BATTERY BOOSTER/CHARGER

WARNING



Always wear a face shield when connecting or disconnecting battery charging cables, and always follow the connection and disconnection sequence. Electrical sparks can cause a battery to explode, resulting in serious injury.

The Vanair® state-of-the-art battery charging module and the optional battery charging cables add further versatility to the 300 Series Power System. The battery charging system operates off the DC generator, and not the main AC power generator.

System Component or Part Group Task	Manual Section	Location
Operating the Battery/Boost Charger	5.7	page 62
Connection - Disconnection Sequence and Operation	5.7.1	page 62

WARNING

NEVER disconnect boosting connections or cables while charging / boosting. This will cause a voltage spike on the machine. Failure to follow this warning can result in injury, and/or damage or failure of any or all electronic components, thus voiding the warranty of the machine.

Consult **Table 5D: FACTORY PRESETS** for factory preset ranges. The module has been factory-adjusted for 12 VDC charging, and a maximum current output of 300 amps.

WARNING

DO NOT charge or boost while in Weld Mode. Personal injury or damage may occur.

IMPORTANT

To prevent damaging voltage spikes, the vehicle battery cables must be disconnected from the battery to be charged in any vehicle equipped with a computer, or any equipment with sensitive electronic components. Failure to follow this warning can result in damage or failure of any or all electronic components of the vehicle.

The module output has been set at 14 VDC for the 12V charge option, 16 VDC for 12V boost, and 30 VDC for the 24V option. This output has been pre-set by the factory and can only be adjusted by authorized factory personnel.

During charging, if the machine begins to cycle between high and low idle, then the battery is fully charged.

5.7.1 CONNECTION - DISCONNECTION SEQUENCE AND OPERATION

TABLE 5D: FACTORY PRESETS

	FACTORY ADJUSTMENT RANGE	STANDARD PRE-SET
12V CHARGER	12V - 15V	14V
12V BOOST	14V - 17V	16V
24V CHARGER/ BOOST	26V - 35V	30V

IMPORTANT

Never attach boost cables to the panel before attaching to the battery. Always attach cables to the battery first.

1. With the machine off, insure that the welder, DC charger switch, and any other motor control switch are in the **OFF** position.
2. Attach the clamps of the battery charge cable to the battery to be charged. RED to the

- positive terminal, BLACK to the negative terminal (*Figure 5-6*).
3. Plug the battery charge cables into the battery cable connection.
 4. Start the machine and wait for all indicator lights to turn off. Place the DC Welder/Charger selector toggle switch in the **DC Charger** position, and then the DC Charger Mode switch to the correct position. The motor should come up to operating speed; the battery is being charged.
 5. When machine begins to cycle between high and bypass then the battery is fully charged.
 6. To disconnect the charging system, place the DC Welder/Charger selector toggle switch to the **OFF** position.
 7. Now it is safe to disconnect the clamps from the battery being charged, and the battery cable connection on the front of the machine.

IMPORTANT

Never leave the machine unattended while charging a battery. Always carefully monitor the charging system while it is in use; the high amperage level that the unit produces can damage the battery being charged, or the other components, if the unit is left connected for an extended period of time.

5.8 EXTREME CONDITION OPERATION

System Component or Part Group Task	Manual Section	Location
Extreme Condition Operation	5.8	page 63
Cold Weather Operation	5.8.1	page 64
General Operation	5.8.1.1	page 64
Machine Operation	5.8.1.2	page 64
High Temperature Operation	5.8.2	page 65
Machine Operation	5.8.2.1	page 65
High Dust Content Operation	5.8.3	page 65
Machine Operation	5.8.3.1	page 65
High Altitude Operation	5.8.4	page 65

When operating in extreme cold or hot conditions, ranging from 0°F to 110°F (-18°C to 43°C) (0°F to -40°F [-18°C to -40°C] with cold weather kit), in the presence of high humidity, or at a high altitude, extra attention should be given to any indication that could lead to a serious problem. If the ambient temperature varies largely, the environment is dusty, or the motor is operated at a high altitude, the motor performance is directly or indirectly influenced.

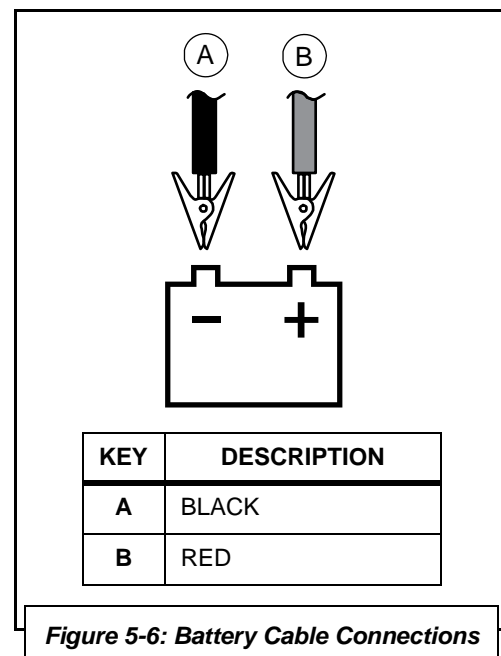

Figure 5-6: Battery Cable Connections

It is necessary to consider the balance between the output compensation in accordance with the ambient conditions, and actions to adapt the motor to the operating conditions.

Machine review and maintenance check schedules should be more frequent than the normal suggestions given in **Section 6.3, Maintenance Schedule Table**.

Become familiar with the alternative operation approaches given in this section before operating the power system package in any type of extreme ambient condition.

5.8.1 COLD WEATHER OPERATION

5.8.1.1 GENERAL OPERATION

WATER

At an extremely cold temperature, the viscosity of hydraulic fluid and lubrication oil may increase, hindering proper starting.

COLD WEATHER SAFEGUARDS

- Park the vehicle or equipment indoors when not in use.
- Use a block heater or glow plugs.
- Vanguard™ Premium Synthetic Oil is suitable for use from -40°F to 110°F (-40°C to 43°C).
- Drain the moisture from the tank when it is warm from extended operation.

5.8.1.2 MACHINE OPERATION

At an extremely cold temperature, the viscosity of hydraulic fluid and lubrication oil may increase, hindering proper starting. Additional care should be taken under consideration when operating the package in extreme cold weather environments or ambient temperatures.

- Run machine with no load at full speed using the generator switch to warm up the machine.
- Heater blanket is available for air inlet solenoid (also see **NOTE** on this page for cold weather kit option).
- For motor precautions, consult the Truck Operator's Manual.

5.8.2 HIGH TEMPERATURE OPERATION

5.8.2.1 MACHINE OPERATION

When operating the machine in high temperature areas, precautions should be taken to prevent overheating. At

NOTE

Vanair® offers a cold weather kit option, installed at the factory, which enables operation at temperatures from 0°F down to -40°F (-18°C to -40°C). Consult Appendix *Section A.5* (options list) and Vanair for details.

the minimum, all coolers, including air passage ways around the coolers, should be free of debris and dirt.

The operator should be aware that high temperatures can influence motor performance, which can directly effect some machine function capacity outputs.

5.8.3 HIGH DUST CONTENT OPERATION

5.8.3.1 MACHINE OPERATION

When the machine is to be used in continuously dusty environments, special care must be taken with the compressor air filter and cooler assembly, as well as the hydraulic fan cooler. This can be accomplished by performing more frequent monitoring of the air filter and coolers when operating in areas that contain a high dust content.

If the machine is not being used for an extended period of time, an additional precaution, such as covering the machine with a tarp, will help to keep the inside of the machine free of dust particle accumulation.

5.8.4 HIGH ALTITUDE OPERATION

Motor horsepower will decrease by 3.5% for every 1,000 ft. increase in altitude. At high altitude overall unit performance will deteriorate, and care will need to be taken not to overload the motor by using more than one function of the unit at a time.

NOTE

If operating the machine in high humidity, the drain valve can be left partially open to relieve water build-up during operation. This water may contain a small amount of oil. Consult *Section A.5*, for order number.

NOTE

The effect of humidity should be taken into consideration when operating in areas with high temperatures.

BLANK PAGE

SECTION 6: MAINTENANCE

6.1 GENERAL INFORMATION

A strict maintenance program is the key to long life for the Air N Arc 300 Series All-In-One Power System package. Below is a program that, when adhered to, should keep the package in top operating condition. Refer to **Section 6.6, Parts Replacement and Adjustment Procedures** in this section of the manual for detailed descriptions of specific compressor system components. The following table lists the main topics in order of appearance for this section:

System Component or Component Group	Manual Section	Location
Routine Maintenance Schedule	6.2	page 67
Maintenance Schedule Table	6.3	page 69
Replacement Parts	6.4	page 72
Maintenance Access	6.5	page 72
Parts Replacement and Adjustment Procedures	6.6	page 73
Servicing the System Fuses and Circuit Breakers	6.7	page 99
Storage and Intermittent Use	6.8	page 99

6.2 ROUTINE MAINTENANCE SCHEDULE

 WARNING
Follow all applicable safety recommendations as outlined in <i>Section 1: Safety of this manual.</i>

Vanair® Manufacturing, Inc. considers the maintenance schedule given in **Section 6.3, Maintenance Schedule Table**, to be part of the warranty agreement with the customer. This maintenance regimen must be followed in order to protect the warranty of the machine package.

 WARNING
<p>DO NOT remove caps, plugs and/or other components when compressor is running or pressurized. Stop compressor and de-pressurize system prior to maintenance of system. Relieve the entire system pressure by opening the air tank drain/vent valve, which will vent all pressure to the atmosphere.</p> <p>Wear personal protective equipment such as gloves, work boots, and eye and hearing protection as required for the task at hand.</p> <hr/> <p>Refer to <i>Figure 6-1</i>. Open fill cap SLOWLY (contents under pressure) to make sure all pressure has been relieved.</p>

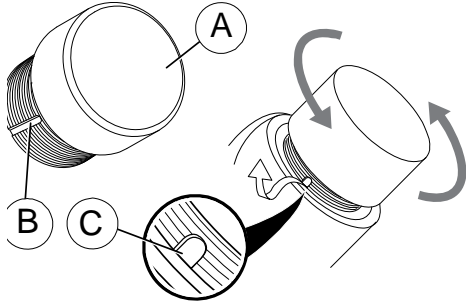

KEY	DESCRIPTION
A	RED COMPRESSOR FILL CAP
B	FILL CAP BLEED VENT GROOVE
C	Open/crack cap slightly to allow bleed vent to relieve pressure

Figure 6-1: Pressure Relief

NOTE

Operating the machine package in a severe environment may require more frequent service intervals.

NOTE

Follow the prescribed periodic maintenance (PM) schedule as recommended. Perform the required PM schedule at recommended intervals. Failure to follow this prescribed periodic maintenance at the recommended intervals will impair the package safety, performance characteristics, shorten the package's life, and will negatively affect the warranty coverage of the package.

Vanair Manufacturing, Inc. especially requires that a consistent service regimen be established for compressor oil changes, and compressor air filter servicing. when the motor and compressor air filters are serviced, and the motor oil is changed.



WARNING

Follow all applicable safety recommendations as outlined in *Section 1: Safety* of this manual.

Please take a moment to acquaint yourself with the following service schedule. There is also a corresponding service log (**Appendix B, Maintenance & Service Log**) to assist the customer in establishing a maintenance routine log.

For assistance in obtaining routine maintenance or replacement parts, consult **Section 9.1, Parts Ordering Procedure**, and **Table 9A: Recommended Spare Parts List**.

6.3 MAINTENANCE SCHEDULE TABLE

KEY	TASK DESCRIPTION	INTERVALS					ACTION TO TAKE		
		BREAK-IN PERIOD	MAINTENANCE SCHEDULE						
			Hourly or Calendar Period - whichever comes first	Every 100 Hours or One Year	Every 200 Hours	After 300 Hours		After 500 Hours	
		First 20 Hours of Operation	Daily	Every 100 Hours or One Year	Every 200 Hours	After 300 Hours	After 500 Hours		NOTE
1	Check tension of micro-v belt that drives the air compressor	●	●	●	●	●	●	●	If working in dusty or dirty conditions, reduce the recommended time intervals between servicing by half for motor and compressor oil change, and motor and compressor filter servicing.
2	Check air tank for water accumulation		●	●	●	●	●	●	Tighten belt if necessary. Consult Section 6.6.15.1 .
3	Check air compressor oil level		●	●	●	●	●	●	Drain any water from the air tank, per procedure in Section 6.6.9 .
4	Inspect unit for oil leaks or damage		●	●	●	●	●	●	Check resting oil level; follow compressor fill procedure (Section 6.6.3) if low.
5	Inspect cooler fins (both motor and compressor oil coolers) for contamination		●	●	●	●	●	●	Visually note any leaks or evidence of leaks around the compressor unit and hose connections. Tighten any loose connection point where needed. Repair or replace any damaged part.
6	Inspect ventilation openings		●	●	●	●	●	●	Clean or clear as necessary. Refer to Section 6.6.11 .
7	Clean and inspect compressor air filter		●	●	●	●	●	●	Ensure openings are not blocked or clogged with debris. Clean or clear as necessary. Consult the air compressor air filter maintenance procedure (Section 6.6.1).
Continued on next page									

6.3 MAINTENANCE SCHEDULE TABLE

		INTERVALS					NOTE
BREAK-IN PERIOD	MAINTENANCE SCHEDULE	Daily	Every 100 Hours or One Year	Every 200 Hours	After 300 Hours	After 500 Hours	
Hours of First 20 Operation	Hourly or Calendar Period - whichever comes first						
KEY	TASK DESCRIPTION	ACTION TO TAKE					
8	Change air compressor oil, oil filter and coalescer element		•			•	Consult the following sections for procedures on how to change compressor oil, oil filter and separator element: Compressor Oil: Sections 6.6.3 and 6.6.5 Compressor Oil Filter: Section 6.6.4 Coalescer Element: Section 6.6.6
9	Inspect air compressor drive belt and serpentine welder drive belt for wear, damage or excessive cracking			•	•	•	Ensure that drive belts are in satisfactory operating condition, and are tensioned adequately. Should a belt need to be re-tensioned or replaced, consult Section 6.6.15 .
10	Check battery cables and connections			•	•	•	Clean and tighten as necessary. Replace any worn cables.
11	Inspect unit mounting bolts			•	•	•	Tighten any loose mounting bolts as necessary.
12	Blow out the DC welding generator and AC generator			•	•	•	Use compressed air to clear out generators (NOTE: carry out every 100 hours if operating in dirty environmental conditions.)
13	Check compressor cut-in and cut-out pressures					•	Ensure that the cut-in and cut-out pressure settings are correct. Adjust if necessary, per Section 6.6.14 .
							Continued on next page

6.3 MAINTENANCE SCHEDULE TABLE

KEY	TASK DESCRIPTION	INTERVALS						ACTION TO TAKE	
		BREAK-IN PERIOD	MAINTENANCE SCHEDULE						
			Hourly or Calendar Period - whichever comes first	Every 100 Hours or One Year	Every 200 Hours	After 300 Hours	After 500 Hours		
		First 20 Hours of Operation	Daily						<p>NOTE</p> <p>If working in dusty or dirty conditions, reduce the recommended time intervals between servicing by half for motor and compressor oil change, and motor and compressor filter servicing.</p>
14	Check the motor speed		●					Ensure that the motor speed is running at correct interval. Adjust if necessary, per Section 6.6.13 .	
15	Inspect the welding leads and battery charging cables					●	●	If so equipped, ensure that welding leads are satisfactory for operation (no cracks or advanced wear). Repair or replace as necessary.	
16	Inspect welding electrode clamp and ground clamp						●	Ensure that welding electrode and ground clamps are in satisfactory for operation (no cracks or advanced wear). Repair or replace as necessary.	
17	Replace the air compressor and generator drive belts						●	Consult Section 6.6.15 on how to replace and re-tension the drive belts.	
18	Inspect the generators and the automatic belt tensioner						●	Ensure that the automatic belt tensioner is free of rough, noisy or worn bearings. Consult Section 6.6.15.3 .	

6.4 REPLACEMENT PARTS

Replacement parts should be purchased through your local Vanair representative or where the 300 Series Power System was purchased. If, for any reason, parts are not available in this manner, they can be purchased through Vanair directly.

NOTE

For assistance when ordering new replacement parts, consult *Section 9.1, Parts Ordering Procedure*, and *Table 9A: Recommended Spare Parts List*.

VANAIR MANUFACTURING, INC.

10896 West 300 N.

Michigan City, IN 46360

Telephone: (800) 526-8817

(219) 879-5100

Service Fax: (219) 879-5335

Parts Fax: (219) 879-5340

Sales Fax: (219) 879-5800

www.vanair.com

NOTE

If additional spare parts are being stored for future use, make certain that they are stored in proper containers that allow for protection against contamination, and kept in a clean area of moderate temperature reading. For information on storing the machine package for periods of non-use, consult *Section 6.8.2, Long Term Storage*.



CAUTION

For safety reasons and to lessen the possibility of damage, a minimum of two personnel should handle the actual removal of the maintenance access panel assembly from the base frame.



WARNING

Relieve pressure from the compressor system before removing any components. The compressor oil level should be checked with the unit shut down and the oil allowed to properly settle.

6.5 MAINTENANCE ACCESS

The maintenance requirements of the Air-N-Arc 300 Series machine package can be accessed via the top hood.

MAINTENANCE ISSUE	SECTION LOCATION
Compressor oil filter (easier to access with panels removed)	6.6.4
Oil Filter Change	I
Belt Replacement	I
Pressure Switch Adjustment	6.6.13
Main Cooler Assembly Cleaning (thorough)	6.6.11
Replace Fuses and Circuit Breakers	6.7
Generator Fuse Replacement	6.7

^IRefer to the Motor Operator's Manual.

6.6 PARTS REPLACEMENT AND ADJUSTMENT PROCEDURES

System Component or Part Group Task	Manual Section	Location
Parts Replacement and Adjustment Procedures	6.6	page 73
Compressor Air Filter	6.6.1	page 74
Compressor Air Filter Check	6.6.1.1	page 74
Compressor Air Filter Inspection	6.6.1.2	page 75
Compressor Air Filter Replacement	6.6.1.3	page 75
Repairing the Air Inlet Valve	6.6.2	page 76
Checking the Compressor Oil	6.6.3	page 78
Replacing the Compressor Oil Filter Element	6.6.4	page 79
Changing the Compressor Oil	6.6.5	page 80
Replacing the Air/Oil Spin-on Coalescer	6.6.6	page 81
Repairing the Compressor Shaft Seal	6.6.7	page 82
Part I - Removing the Compressor Serpentine Belt	6.6.7.1	page 82
Part II - Accessing the Compressor Unit Shaft Seal	6.6.7.2	page 84
Part III - Replacing the Compressor Serpentine Belt	6.6.7.3	page 85
Replacing the Air Inlet Solenoid Valve	6.6.8	page 85
Solenoid Valve—Preparation Before Mounting	6.6.8.1	page 87
Connecting the New Solenoid Valve	6.6.8.2	page 87
Draining the Air Tank	6.6.9	page 88
Rebuilding the Minimum Pressure/Check Valve	6.6.10	page 90
Setting the Minimum Pressure Valve	6.6.10.1	page 90
Inspecting the System Coolers	6.6.11	page 91
Adjusting The Motor Speed	6.6.12	page 92
<i>Continued on next page</i>		

 **CAUTION**

Always wear personal protective equipment such as gloves, safety shoes or boots, eye, and hearing protection as required for the task at hand.

 **CAUTION**

Compressors and motors generate heat and create hot surfaces. Use caution when operating or servicing equipment. Some surfaces and components may be hot.

NOTE

It may be necessary to change the compressor oil and oil filter at earlier intervals if the compressor oil has water contamination or if the compressor system is operated in a dirty environment.

NOTE

Do not mix different compressor fluid types. Use Vanguard compressor oil.

NOTE

Refer to the Truck Operator's Manual for detailed maintenance and replacement procedures for the motor.

NOTE

Inspect and replace damaged components before operation with Genuine Vanair Replacement Parts. Using replacement parts other than Genuine Vanair Replacement Parts will void the warranty.

WARNING
Relieve pressure from the compressor system before removing any components.

Adjusting The Pressure Setting	6.6.13	page 92
Replacing and Re-tensioning the Serpentine Drive Belts	6.6.14	page 94
Re-tensioning the Air Compressor Serpentine Drive Belt	6.6.14.1	page 94
Replacing the Air Compressor Serpentine Drive Belt	6.6.14.2	page 95
Re-tensioning the Generator Serpentine Drive Belt	6.6.14.3	page 96
Replacing the Generator Serpentine Drive Belt	6.6.14.4	page 97

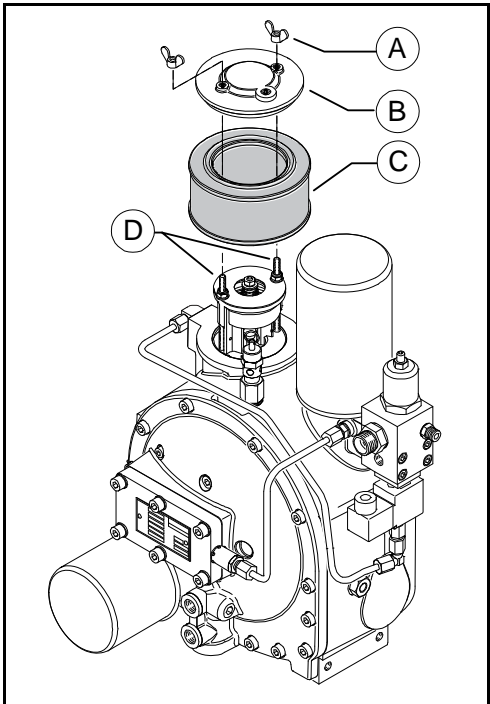

KEY	DESCRIPTION
A	WING NUT (x 2)
B	AIR FILTER MOUNTING COVER
C	AIR FILTER HOUSING ELEMENT
D	MOUNTING POSTS (x 2)

Figure 6-2: Compressor Air Filter

NOTE
If element is compromised by dirt, holes, tears, or the gaskets are worn, or it is in unsatisfactory condition, then it will need to be replaced.

6.6.1 COMPRESSOR AIR FILTER

The compressor oil is the key to a long useful life of the air compressor system. Dirt and other foreign matter can be introduced into the compressor system through the air intake. A clean air filter will ensure that the compressor is protected. Consult **Section 6.3, Maintenance Schedule Table** for routine compressor air filter inspection intervals.

6.6.1.1 COMPRESSOR AIR FILTER CHECK

Consult **Figure 6-2** and the following procedure to check the compressor air filter.

TOOLS/ITEMS NEEDED
Not Applicable

REPLACEMENT PART(S)
Not Applicable

1. With the machine off and the ignition key removed, open the hood panel.
2. Remove the two (2) wing nuts [A] from the air filter cover [B] at the top of the compressor unit.
3. Remove air filter element [C] from the air filter mounting posts [D].
4. Inspect the air filter element for visible dirt, debris, or damage. **NOTE:** To perform a more thorough inspection of the compressor air filter element, refer to **Section 6.6.1.2**.

If element is in adequate shape to continue using:

5. Re-seat the filter element [C] onto the air filter mounting posts [D]

6. Replace cover [B] and wing nuts [A].
7. Close hood.

6.6.1.2 COMPRESSOR AIR FILTER INSPECTION

Consult **Figure 6-3** and the following procedure to inspect the compressor air filter.

TOOLS/ITEMS NEEDED
Light source

REPLACEMENT PART(S)
Not Applicable

1. Place a bright light source inside of the filter element and carefully inspect the filter from the outside in a dark environment to detect any pinholes or tears that may have developed.
2. Inspect the gaskets on the top and bottom of the air filter for any damage or wear.
3. Replace the element if it shows any damage or wear even if the inspection occurs before the recommended replacement interval. Consult **Section 6.6.1.3** if filter needs to be replaced.

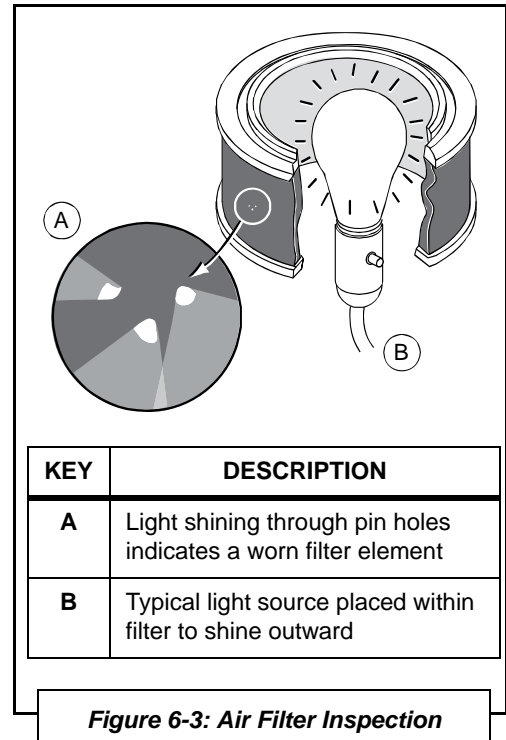

6.6.1.3 COMPRESSOR AIR FILTER REPLACEMENT

The air filter element uses a pleated paper-type filter to carefully remove accumulated dirt before compression can begin. **DO NOT** clean the compressor air filter element.

TOOLS/ITEMS NEEDED
Container large enough to accommodate filter

REPLACEMENT PART(S)
Air Filter Element No. 264469

 WARNING
Relieve pressure from the compressor system before removing any components.

To replace worn or damaged air filter with new filter, consult **Figure 6-2**, and the following procedure:

1. With the machine off and the ignition key removed, open the hood panel and locate the compressor air filter.
2. Remove two (2) wing nuts [A] from the air filter cover [B] at the top of the compressor unit.
3. Remove worn air filter element [C] from the air filter mounting posts [D].

4. Seat a new filter element [C] onto the filter mounting posts [D].
5. Replace cover [B] and wing nuts [A].
6. Close the hood.
7. Dispose of discarded filter within the guidelines of all applicable local, regional and/or federal laws.

6.6.2 REPAIRING THE AIR INLET VALVE

Should a condition occur that requires air inlet valve maintenance (see **Section 7.2, Troubleshooting Guide**), a repair kit is available. To repair the air inlet valve, order air inlet rebuild kit no. 264154-102. Refer to **Figure 6-4**, and the following procedure:

 IMPORTANT
DO NOT let loose parts fall into the air inlet.

TOOLS/ITEMS NEEDED
Hex Head Screwdriver or Wrench
Adjustable Wrench

REPLACEMENT PART(S)
Air Inlet Rebuild Kit No. 264154-102

1. Shut down machine and lock out all power, as per the Safety Section of the manual.
2. Locate the compressor’s air filter compartment housing and remove the two (2) wing screws [A] from cover [B].
3. Remove air filter [C], and put it aside temporarily so it will not get damaged or soiled; the full air filter inlet valve [D] is now accessible.
4. Remove the two (2) nuts [E] and two (2) washers [F] from the mounting posts [V].
5. Grasp the governor body [P] and pull upwards to disengage the valve from its seating.
6. Disassemble the valve and replace used parts with new parts found in the kit. Refer to **Figure 6-4** to assure correct part positions for re-assembly.
7. Once the valve’s parts have been replaced with the kit parts and re-assembled, place the rebuilt, complete inlet valve assembly back into position on the mounting posts [V].
8. Replace the two (2) nuts and two (2) washers [F] on the mounting posts [V], and tighten securely.
9. Replace the air filter [C], or exchange it for a new one if air filter is soiled (refer to **Section**

NOTE
Valve is under spring tension

NOTE
Use all of the parts provided in the kit regardless of the replaceable part’s condition.

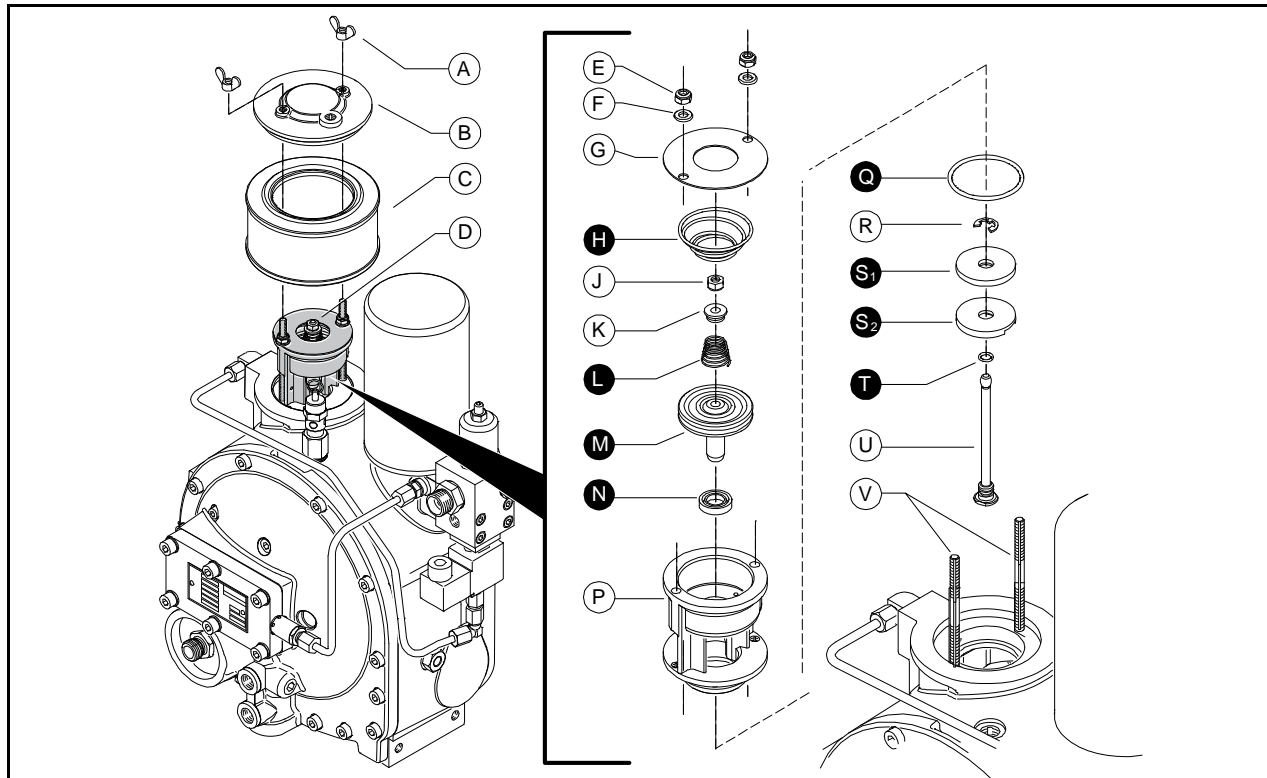

KEY	DESCRIPTION	KEY	DESCRIPTION
○ - ASSEMBLY PART		● - KIT (REPLACEMENT) PART	
A	WING NUT (x 2)	M	PISTON (COMPLETE with RING)
B	AIR FILTER MOUNTING COVER	N	V-RING
C	AIR FILTER ELEMENT	P	GOVERNOR HOUSING
D	AIR INLET VALVE - COMPLETE ASSEMBLY	Q	O-RING
E	NUT (x 2)	R	LOCK WASHER
F	WASHER (x 2)	S	PLATE SET:
G	SPRING GUIDE	S ₁	VALVE HEAD
H	SPRING	S ₂	WEIGHT
J	NUT	T	O-RING
K	SPRING GUIDE	U	CONTROL LINKAGE
L	SPRING	V	MOUNTING POSTS

Order Air Inlet Valve Rebuild Kit no. 264154-102.

Figure 6-4: Air Inlet Valve Rebuild Kit

6.6.1, Compressor Air Filter for air filter inspection check, etc.).

10. Replace the cover [B].
11. Replace the two (2) wing nuts [A], and secure tightly.

6.6.3 CHECKING THE COMPRESSOR OIL

WARNING

DO NOT remove caps, plugs and/or other components when compressor is running or pressurized. Stop compressor and de-pressurize system prior to maintenance of system. Relieve the entire system pressure by opening the air tank drain/vent valve, which will vent all pressure to the atmosphere.

Refer to *Figure 6-1*. Open fill cap SLOWLY (contents under pressure) to make sure all pressure has been relieved.

DANGER

NEVER check the compressor oil level with the compressor running. Hot oil is under pressure and will spray, causing severe burns.

When checking compressor oil level, blow down the pressure to zero and allow system oil level to settle before removing the fill cap.

Having the proper amount of oil in the compressor system is essential to prolonging the equipment's useful life. Checking the compressor oil is the most important service to perform on the 300 Series All-In-One Power System package. Consult **Section 6.3, Maintenance Schedule Table** for routine compressor oil inspection intervals.

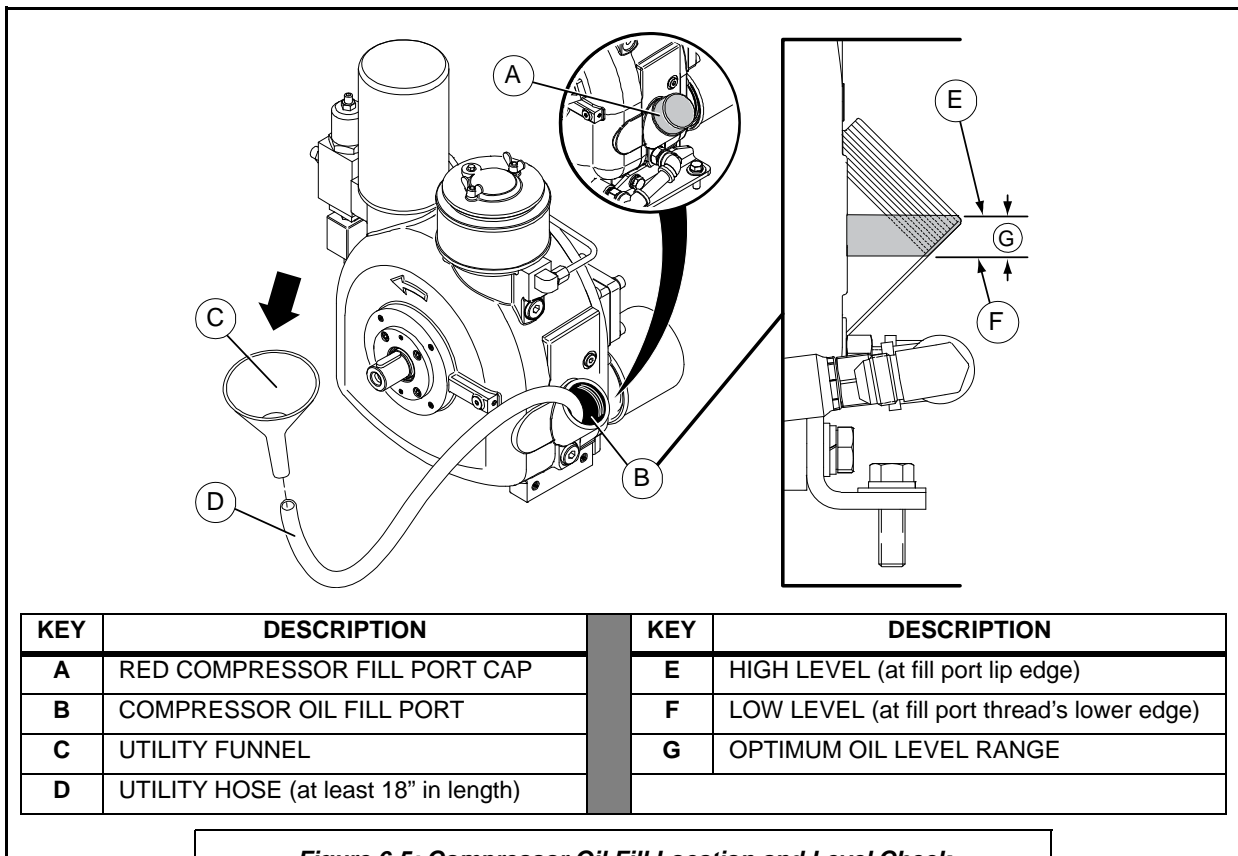

Consult **Figure 6-5** and the following procedure to check the compressor oil.

TOOLS/ITEMS NEEDED
Strap Wrench
Adjustable Wrench

REPLACEMENT PART(S)
Vanguard™ Premium Synthetic Oil No. 264626-1GAL

1. With the machine off and the ignition key removed, open the hood panel.
2. Locate the fill port of the compressor, and unscrew and remove the red oil fill cap [A].
3. Verify the oil level by comparing actual level to range [G] in **Figure 6-5**.
4. Add oil as needed; addition of oil to compressor chamber can be more easily accessed by using a utility hose [D] and funnel [C], as per **Figure 6-5**.
5. Replace the oil fill cap.

6.6.4 REPLACING THE COMPRESSOR OIL FILTER ELEMENT

The compressor oil filter element is a spin-on disposable type. Consult **Figure 6-6**, and the following procedure to change the compressor oil filter element. Consult **Section 6.3, Maintenance Schedule Table** for routine compressor oil element change intervals.

NOTE
For ease of access, the maintenance access panel assembly will need to be removed. Consult Section 6.5.

TOOLS/ITEMS NEEDED
Strap Wrench
Compressor Oil (enough to coat seal ring, and possibly for a top-off to the proper level)

REPLACEMENT PART(S)
Oil Filter Element No. 264471

1. With the machine off and the ignition key removed, open the hood panel access door.

 WARNING
Compressor oil can ignite if it comes in contact with very hot surfaces, like a muffler or exhaust manifold on the motor.

NOTE
This procedure should only be performed when the compressor is warm immediately after extended operation.

NOTE
The cooler has an aluminum core and if internal cleaning is required, it should be done at a qualified radiator shop. If the lubrication system is properly maintained (changing the oil and filters at the recommended intervals) an internal cleaning should not be necessary during the compressor's service life.

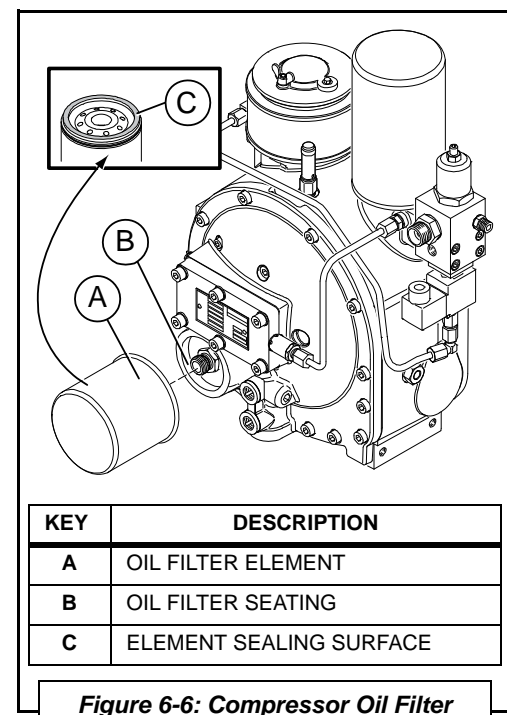

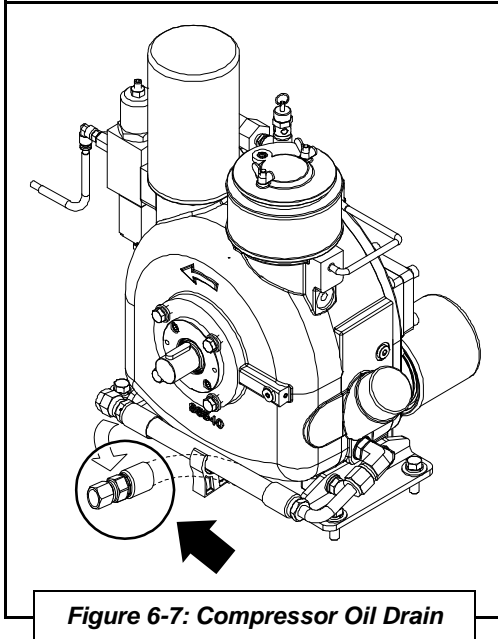

2. Locate the compressor oil filter on the compressor unit body as per **Figure 6-6 [A]**.
3. Remove the worn oil filter element **[A]** by turning it counterclockwise using a strap wrench.
4. Clean the filter seating **[B]** on the compressor unit with a lint-free wiper or cloth.
5. Apply a light film of compressor oil to the replacement element's sealing surface rim **[C]** for an air-tight seal between the element and the filter seating.
6. Install the new element **[A]** by manually turning it clockwise onto the filter seating **[B]** until the seal contacts the machined groove on the rim of the filter seating. Then turn an additional 3/4 of a turn, using a strap wrench if necessary.
7. Run the compressor and check for leaks.
8. Dispose of discarded filter within the guidelines of all applicable local, regional and/or federal laws.

To check and/or replace or refill the compressor system, refer to **Section 6.6.5**.

6.6.5 CHANGING THE COMPRESSOR OIL

During periodic maintenance intervals, or more frequently if needed, it will be necessary to perform a complete compressor system oil change. Follow the procedure below, along with **Figure 6-7** and **Sections 6.6.3, 6.6.4** and **6.6.6** to change the oil.

 WARNING
<p>Before starting, performing maintenance, or replacing parts, relieve the entire system pressure by opening the air tank drain/vent valve, which will vent all pressure to the atmosphere.</p>
<p>Refer to Figure 6-1. Open fill cap SLOWLY (contents under pressure) to make sure all pressure has been relieved.</p>

NOTE
<p>This procedure should only be performed when the compressor is warm immediately after extended operation.</p>

TOOLS NEEDED	REPLACEMENT PART(S)
Clean Utility Hose (18" in length)	Vanair® Vanguard™ Premium Synthetic Oil No. 264626-1GAL
TOOLS NEEDED	REPLACEMENT PART(S)
Clean Utility Funnel	Oil Filter Element No. 264471
Strap Wrench	Air/Oil Coalescer Element No. 264470
Adjustable Wrench	
Oil Pan	
Clean Rag or Towel	

1. With the machine off and the ignition key removed, place a suitable receptacle under the compressor drain tube end and remove the drain cap.
2. After oil has completely drained, securely replace the drain cap.
3. Replace the oil filter (see **Section 6.6.4** for instructions on how to replace the compressor oil filter element).
4. Replace the air/oil coalescer (see **Section 6.6.6** for instructions on how to replace the spin-on air/oil coalescer filter).
5. Once the oil filter and air/oil coalescer have been replaced, access the compressor oil fill port by removing the cap ([A] in **Figure 6-5**) and filling the compressor unit to the service capacity level (two and a half [2.5] quarts) with Vanguard™ Premium Synthetic Oil. Note the acceptable range for the oil level [G] from **Figure 6-5** when filling the compressor unit reservoir.

	IMPORTANT
Only Use Vanguard Premium Synthetic Oil.	

6. Run the compressor momentarily, turn off, and verify that the level of compressor oil [G] is within satisfactory range.

6.6.6 REPLACING THE SPIN-ON AIR/OIL COALESCER

The air/oil coalescer element is a spin-on disposable type. Consult **Figure 6-8**, and use the following procedure to replace the coalescer element. Consult **Section 6.3, Maintenance Schedule Table** for routine coalescer element change intervals.

TOOLS NEEDED	REPLACEMENT PART(S)
Strap Wrench	Coalescer Replacement Element No. 264470
Compressor Oil (to coat seal)	

1. With the machine off and the ignition key removed, open the hood panel.
2. Locate the spin-on element situated on the topside at the rear of the compressor unit.

NOTE
DO NOT overfill the compressor system; stay within the recommended guidelines as prescribed in Section 3, Table 3B: Specifications - Air Compressor.

NOTE
For extreme weather conditions, refer to Section 5.8.

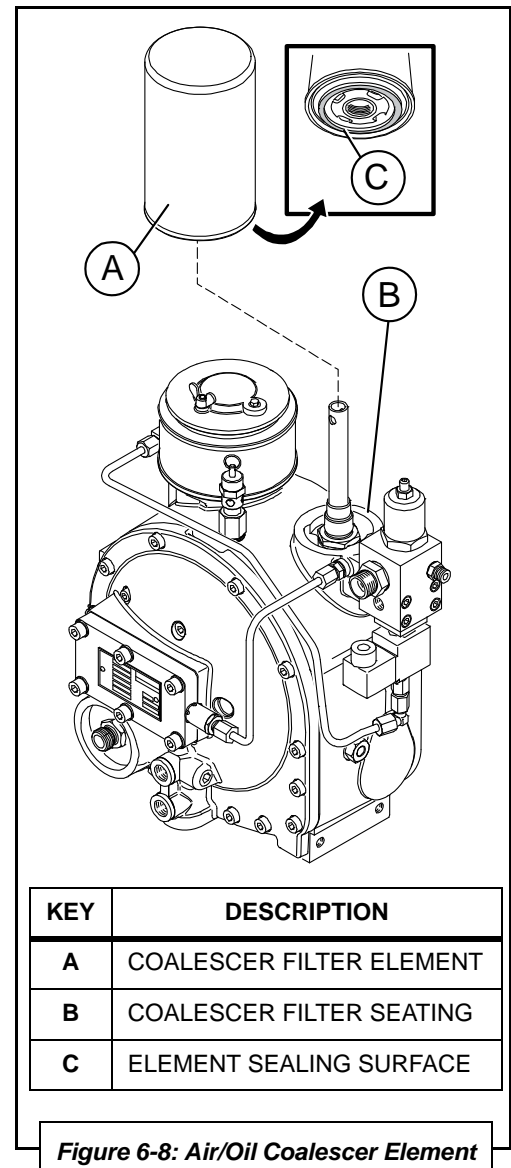

3. With the aid of a strap wrench, remove the old element [A] by turning it counterclockwise.
4. Apply a thin coat of compressor oil to the new seal [C] on the new element.
5. Install the new element [A] into place on the filter seating [B].
6. Turn element clockwise until it seats snugly. Rotate one more complete turn, using a strap wrench if necessary.
7. Run the compressor and check for leaks.
8. Dispose of discarded filter and drained oil within the guidelines of all applicable local, regional and/or federal laws.

6.6.7 REPAIRING THE COMPRESSOR SHAFT SEAL

If the air compressor shaft seal requires servicing, order shaft seal repair kit no. 270766.

The compressor belt and compressor drive sheave must first be removed in order to access the seal components. Refer to **Figure 6-9**, and the following procedure to perform maintenance on the compressor shaft seal:

TOOLS NEEDED	REPLACEMENT PART(S)
Wrench - Size 6mm Hex Head	Shaft Seal Rebuild Kit No. 270766
Torque Wrench, 1/2" Drive	
Clean Cloth	
Puller Tool	

6.6.7.1 PART I – REMOVING THE COMPRESSOR SERPENTINE BELT

1. With the truck/vehicle off and the ignition key removed, open the front access panel.
2. Slightly loosen the four (4) capscrews [L] enough to allow the compressor sheave (air end) tensioner plate [P] to rotate/slide counterclockwise [Insert P1] to its maximum position allowed by the plate's slots. This maximum position will loosen the serpentine belt [F] enough to be removed.
3. Remove serpentine belt [F].

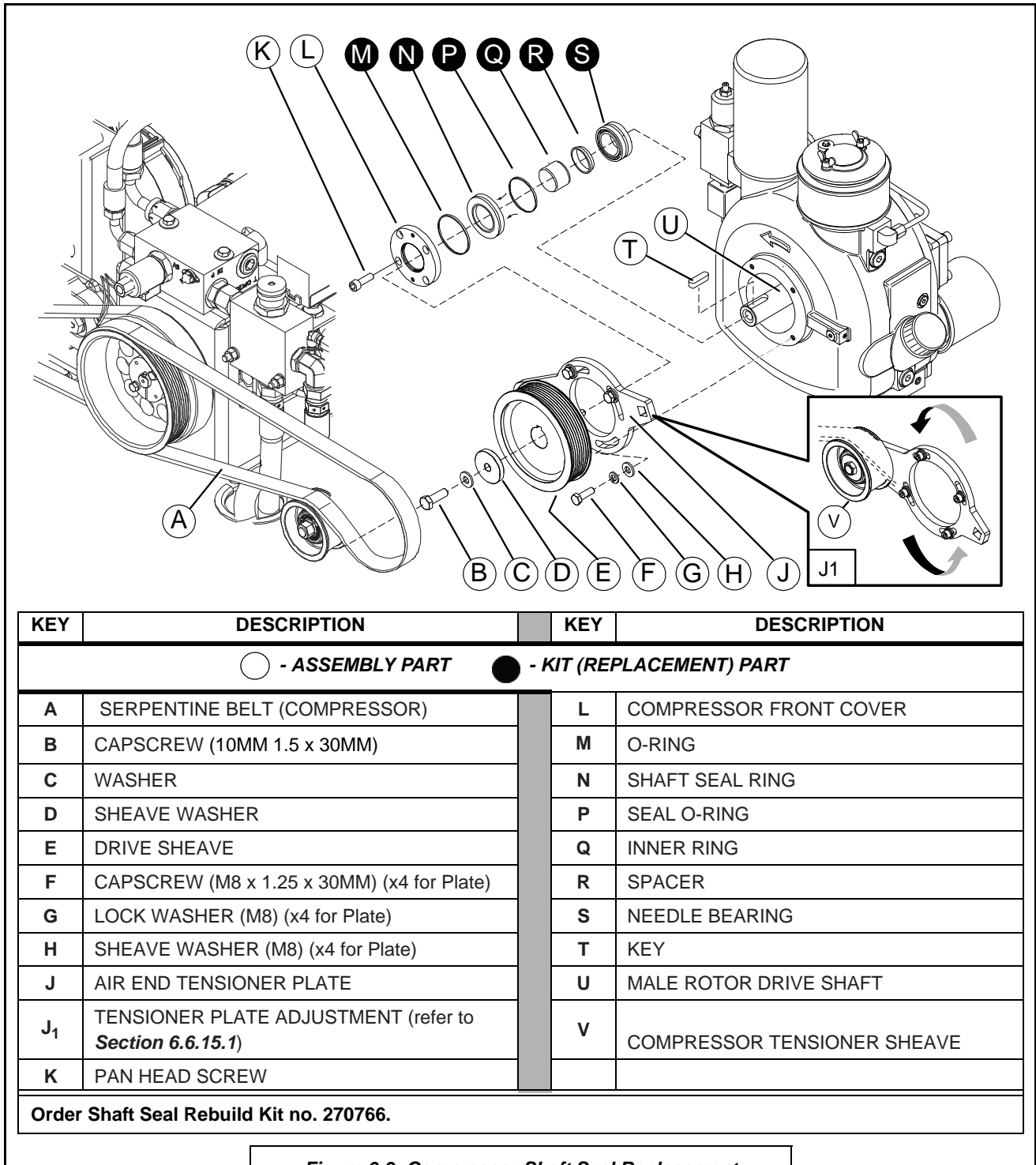

Figure 6-9: Compressor Shaft Seal Replacement

6.6.7.2 PART II – ACCESSING THE COMPRESSOR UNIT SHAFT SEAL

1. Loosen and remove the drive sheave capscrew [G], washer [H] and sheave washer [J] securing drive sheave [K] into place.
2. Remove the drive sheave [K] from the end of the male rotor drive shaft [Z].
3. Remove key [Y] from the groove in the end of the male rotor drive shaft [Z].
4. Loosen and remove the four (4) M8 capscrews [L], and also the lock washers [M], and sheave washers [N] securing the tensioner plate [P] into place.
5. Remove the four pan head capscrews [Q], securing the front cover [R] to the front of the compressor unit.
6. Remove the front cover [R] to expose the seal assembly. Remove the worn o-ring [S], shaft seal ring [T], seal o-ring [U], inner ring [V], spacer [W] and needle bearing [X] from the end of the male rotor drive shaft [Z].
7. Wipe down any excess contaminants that may have accumulated on the male rotor drive shaft.
8. Replace the needle bearing [X] and spacer [W] with their new counterparts from the kit.
9. Replace inner ring [V] with its new counterpart from the kit; the inner ring should be gently tapped into place using the tool as a guide. Note that it should seat snugly on the spacer [W].
10. Replace metal seal o-ring [U] within the lip-end of the new shaft seal ring [T] (both parts from the kit).
11. Gently tap the shaft seal ring [T] onto the male rotor [Z].
12. When the edge of shaft seal ring [T] is flush with the inner ring [V] on the shaft, the shaft seal is in position.
13. Lubricate new o-ring [S] with the silicon lubrication supplied with the kit.
14. Place o-ring [S] within the groove on the inside of the compressor cover [R].

NOTE

Before attempting to affix the seal to the shaft, make note that the lip-end side of the shaft seal (which contains the seated metal seal o-ring [U]), faces the rotor.

15. Place the compressor cover [R] over its seating position on the compressor unit body.
16. Fasten compressor cover [R] to compressor body using the four (4) pan head screws [Q]. Tighten bolt pairs evenly in a criss-cross pattern (**Figure 6-10**).
17. Place the compressor tensioner plate [P] so that its holes line up with its compressor mounting surface.
18. Fit a lock washer [M] and sheave washer [N] over an M8 capscrew [L], and place it through one of the upper aligned holes of the tensioner plate and compressor cover. Screw it into place snugly, but not fully tightened.
19. Repeat Step #18 for the three remaining holes until the aligned tensioner plate [P] is secured (but not tightened) to the compressor unit; do not tighten the capscrews yet, as the tensioner plate will have to be adjusted to allow for repositioning of the tensioner sheave/serpentine belt.

6.6.7.3 PART III – REPLACING THE COMPRESSOR SERPENTINE BELT

1. Replace/re-thread the serpentine belt [F] back onto the motor sheave and compressor drive sheave [K], making sure that the belt lies over the compressor tensioner sheave [AA] (as shown in insert P1).
2. For details on how to adjust the compressor belt tension, consult **Section 6.6.15.1, Retensioning the Air Compressor Serpentine Belt**. Note that if either of the serpentine belts driving the compressor or the generator needs to be replaced, then both should be replaced at the same time (consult **Section 6.6.15** in this Operator's Manual).

6.6.8 REPLACING THE AIR INLET SOLENOID VALVE

If an air inlet malfunction is caused by a faulty solenoid signal, the solenoid valve will need to be replaced. Order air inlet valve replacement kit no.270775. Refer to **Figure 6-11**, and the following procedures:

NOTE

If present, scrape off any remnant pieces of previous gasket from the compressor cover [R] before replacing o-ring.

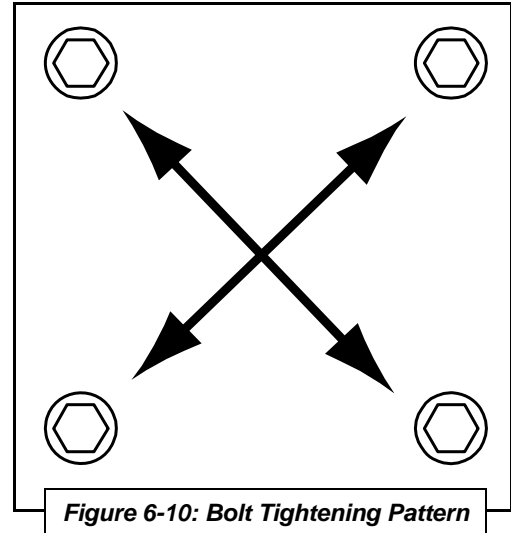

Figure 6-10: Bolt Tightening Pattern

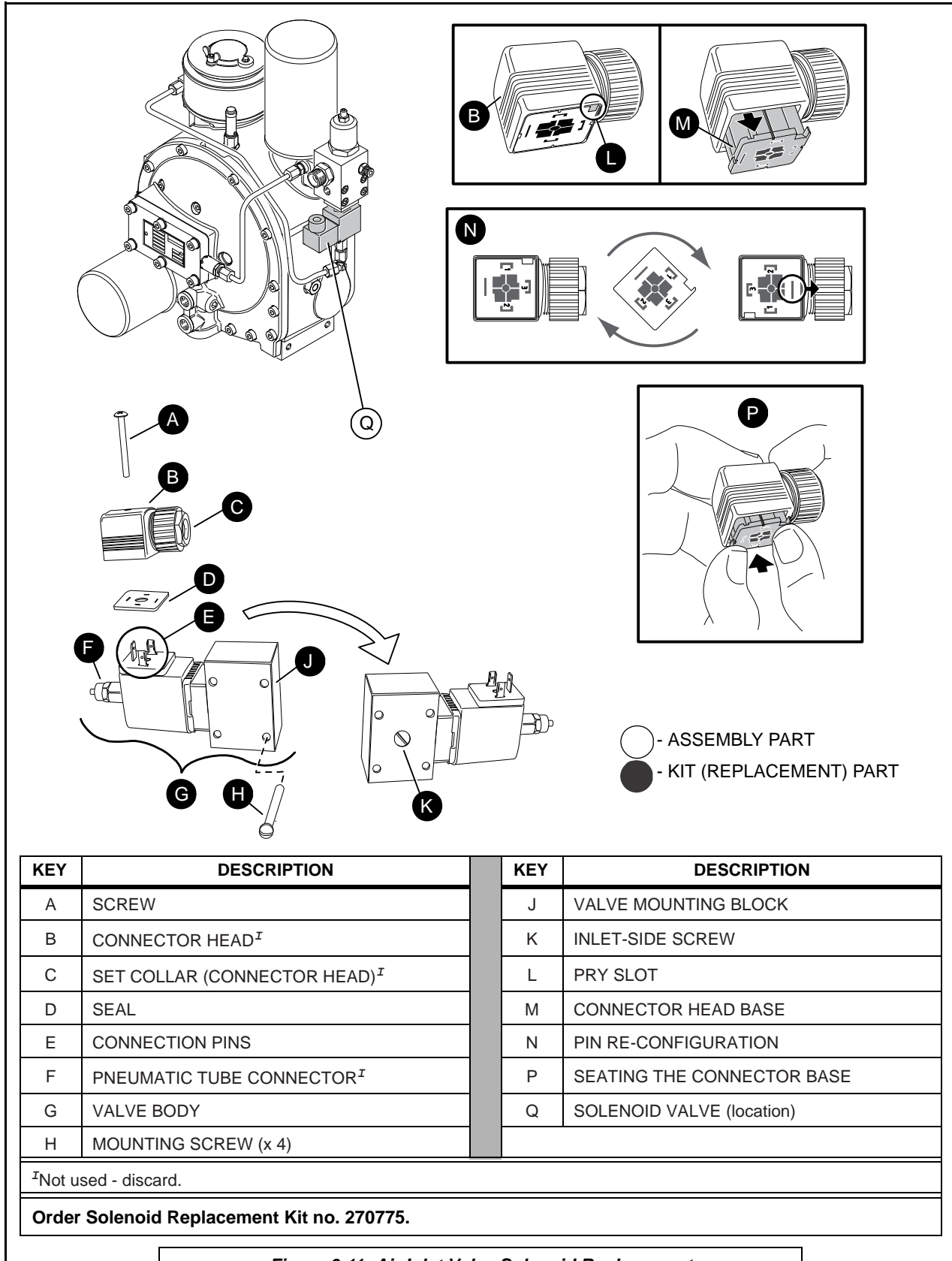

Figure 6-11: Air Inlet Valve Solenoid Replacement

TOOLS NEEDED	REPLACEMENT PART(S)
Screwdriver	Solenoid Replacement Kit No. 270775

6.6.8.1 SOLENOID VALVE – PREPARATION BEFORE MOUNTING

Before installing the new solenoid, the connector's base needs to be rotated so that the connector situates correctly with the wire direction once it is plugged into the solenoid block. To achieve the correct connector base configuration:

1. Unpack the new solenoid valve from the kit packaging.
2. Remove the screw [A] securing the connector head [B] to the valve body [G], and gently pull the connector away from the solenoid block's connection pins [E].
3. Remove the seal [D].
4. Set the solenoid block aside, taking care not to bend or damage the three connector pins [E].
5. Insert a screwdriver into the access indent on the base [K]. Apply prying pressure to the pry slot [L], so that the base comes away from the connector head (shown in [M]).
6. Rotate the base so that the slit corresponding to the only flat pin is closest to the wire connection end of the valve connector head, as shown in [N].
7. While holding the connector, with your thumbs, push the base into the connector head until it snaps into place [P]. Base should be flush with the connector head to assure a good seating.
8. Replace the seal [D] over the pins [E] on the valve body.
9. Gently push the connector head [B] onto the valve body; the pins will now align the collar side [C] of the connector head so that it points away from the valve mounting block [J] side of the valve body.

6.6.8.2 CONNECTING THE NEW SOLENOID VALVE

Refer to *Figure 6-11* and the following procedure:

1. With the machine off and the ignition key removed, locate the inlet solenoid valve [Q] mounted on the compressor's control manifold.
2. Remove the top securing screw [A] of the valve connected to the unit, and gently pull the connector away from the solenoid block's connection pins [E].
3. Remove the wires connected to the valve connector head [B] by unscrewing the collar [C] securing the wires in place.
4. Remove the collar from the pneumatic tube connection [F] to separate the tube from the body.
5. Remove the four (4) screws [H] securing the solenoid block to the unit.
6. Position the new solenoid valve body so that the four (4) mounting holes of the valve body align with the four (4) holes on the unit mounting surface. Note that the screw [K] side of the new valve faces into the compressor unit.
7. Use the four (4) mounting screws from the kit [H] to secure the new valve body to the compressor unit.
8. Unplug the connector head from the new solenoid body, but leave the seal in place.
9. Unscrew the collar [C] from the new connector head.
10. On the wire, replace the old connector collar with the new one from the new connector head.
11. Run the collar up the wire, and secure it to the valve connector head.
12. Position the connector head onto the valve body making sure the pins align correctly before applying pressure.
13. Connect the pneumatic tube [F] to the new valve body.
14. Test the unit to assure that the valve is working properly.

NOTE

If operating the machine in high humidity, the drain valve can be left partially open to relieve water build-up during operation. This water may contain a small amount of oil.

6.6.9 DRAINING THE AIR TANK

Refer to **Figure 6-12**. The air tank reservoir may accumulate a moisture build-up on the inside due to the compression of air. The air tank should be checked daily and allowed to drain by opening the drain cock on the ball

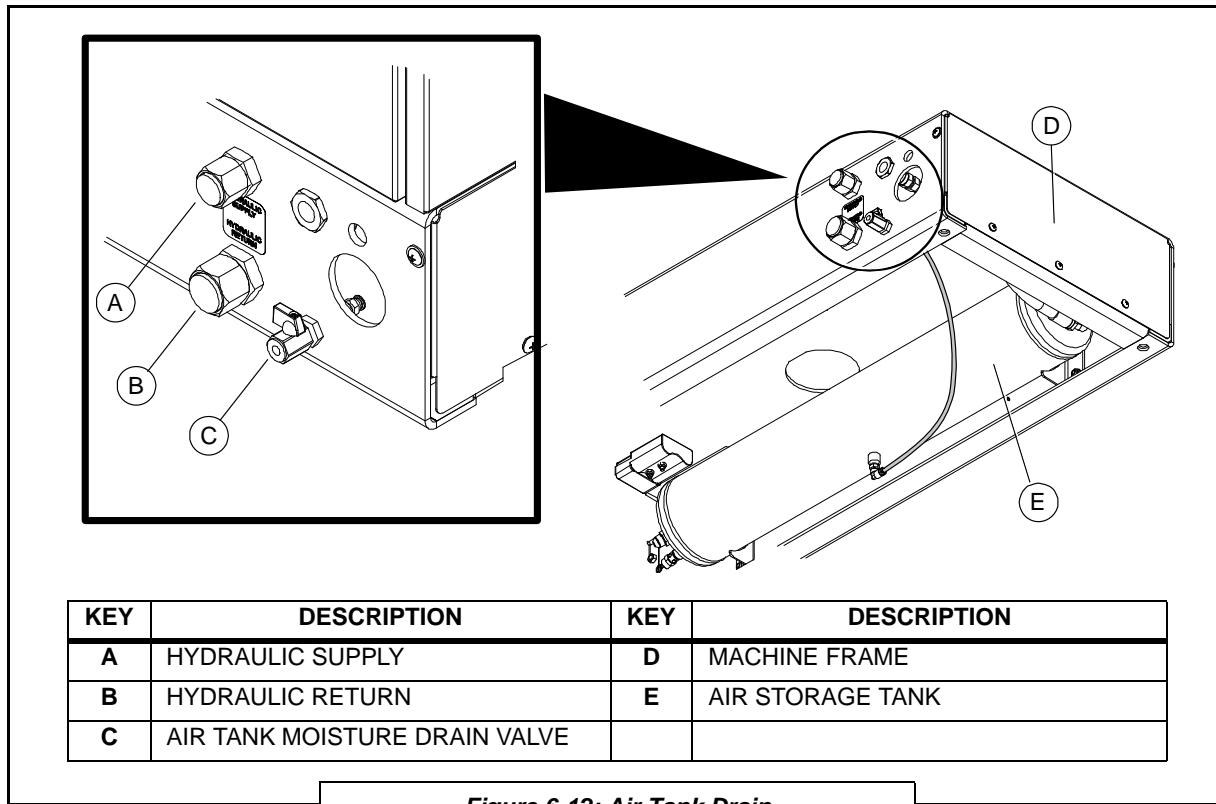

Figure 6-12: Air Tank Drain

valve located at the lower right corner of the base frame on the back end of the machine. For areas of high ambient moisture content the valve may need to be checked more than once per day. This valve may be accessed at any time, including while the machine is in operation.

TOOLS NEEDED
Catch Tray or Cloth to Absorb Drained Moisture

REPLACEMENT PART(S)
Not Applicable

1. Turn handle of drain valve [A] to release moisture buildup. If preferred, place a container below the valve to catch discharge.

NOTE

The 1/4" NPT fitting at the end of the drain valve can be piped to a holding tank.

2. Close the valve after the water has drained off.

6.6.10 REBUILDING THE MINIMUM PRESSURE/ CHECK VALVE

Should a condition occur that requires the minimum pressure/check valve to be serviced (see **Section 7.2, Troubleshooting Guide**), a repair kit is available. To repair the minimum pressure/check valve, order minimum pressure/check valve kit no. 270765. Refer to **Figure 6-13**, and the following procedure:

TOOLS NEEDED	REPLACEMENT PART(S)
Clean Cloth	Minimum Pressure/ Check Valve Rebuild Kit No. 270765
Adjustable Wrench	

1. With the machine off and the ignition key removed, open the hood panel.
2. Locate the minimum pressure/check valve [A] situated on the compressor unit's control manifold, close to the coalescer element.
3. Loosen and remove the lock nut [B] securing the grub screw [C] in position.
4. Loosen the grub screw [C] to relieve any spring tension in the valve.
5. Loosen and carefully remove the valve body [D], which holds the internal parts in place. The internal parts will be freed to drop out with the removal of the valve body.
6. Wipe internal surface of valve body [D] with a clean cloth.
7. Consult **Figure 6-13**, and re-assemble the kit by replacing all old parts with corresponding part provided in the kit.
8. Once the kit parts (parts E through L) have been situated in correct order into the valve body, replace the valve body back into the mounting position. Retighten body securely.
9. Replace the grub screw [C] into position on valve body [D], and hand-tighten. Replace the lock nut [B] over the grub screw, and position it loosely over the grub screw.

NOTE

Use all of the parts provided in the kit regardless of the replaceable part's condition.

6.6.10.1 SETTING THE MINIMUM PRESSURE VALVE

1. Start the machine and allow it to assume idle speed.

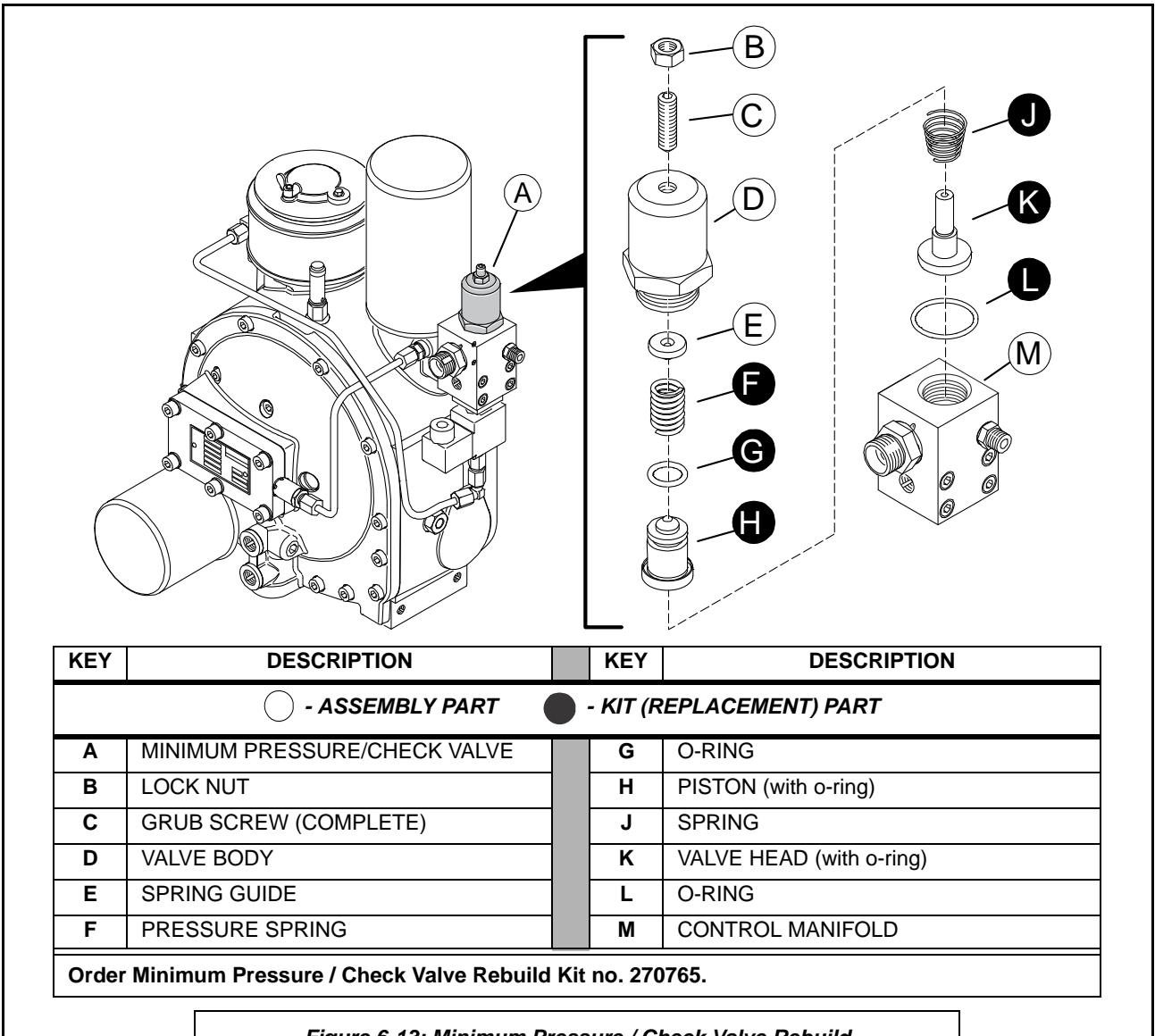

2. Start the compressor and allow it to accumulate pressure build-up.
3. Using the panel pressure gauge as a guide, adjust the grub screw [C] until minimum pressure level is achieved.
4. Tighten the lock nut [B] to secure the grub screw at the proper minimum pressure level.

6.6.11 INSPECTING THE SYSTEM COOLERS

Refer to **Figure 6-14**. Periodically as per **Section 6.3, Maintenance Schedule Table**, inspect the cooler fins of both the motor and the compressor for any build up of dirt

NOTE

Use only low pressure air to clean the cooler fins. **DO NOT** use high pressure air or a pressure washer.

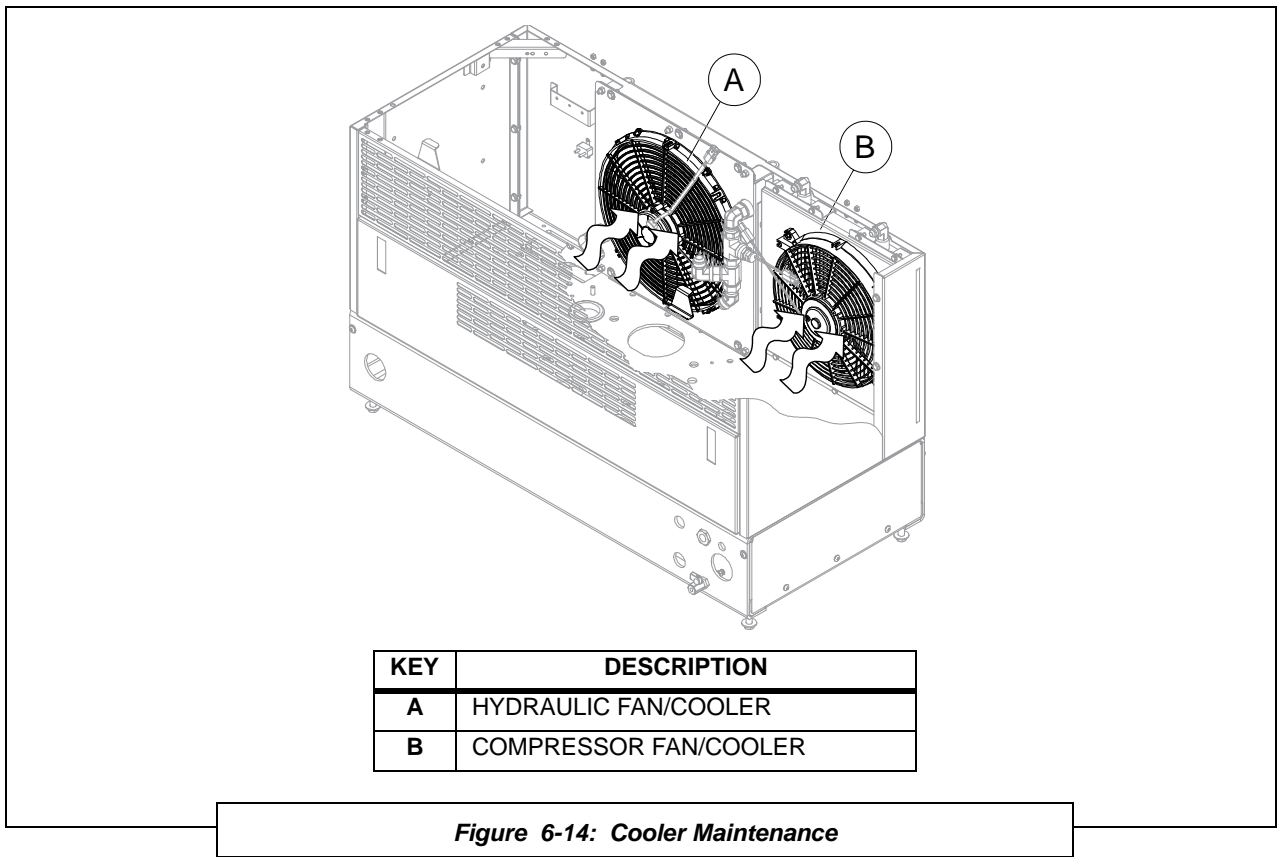



Figure 6-14: Cooler Maintenance

or contamination. Should any residue appear during inspection, clear with the use of air blown across the surface of the cooler fins.

6.6.12 ADJUSTING THE MOTOR SPEED

Consult the Vanair® Service Department for issues relating to adjustment of motor speed.

 WARNING
<p>The compressor cut-in/cut-out pressures have been factory-adjusted within the limits of the compressor manufacturer. The maximum pressure limit of the compressor is 175 psi. Pressure should never be allowed to go beyond this limit or what has been set by local laws and regulators. This system will disengage the clutch at 185 psi. A 200 psi safety relief valve is located on the air tank to prevent over pressurizing the system.</p>

NOTE
<p>Do not tamper with the flow control setting to increase the maximum motor speed. Overspeed is hazardous and will void the motor warranty.</p>

6.6.13 ADJUSTING THE PRESSURE SETTING

The **Cut-in pressure** is defined as the pressure in which the compressor starts pumping. Anytime the pressure in the tank falls below this pressure the compressor is allowed to start pumping.

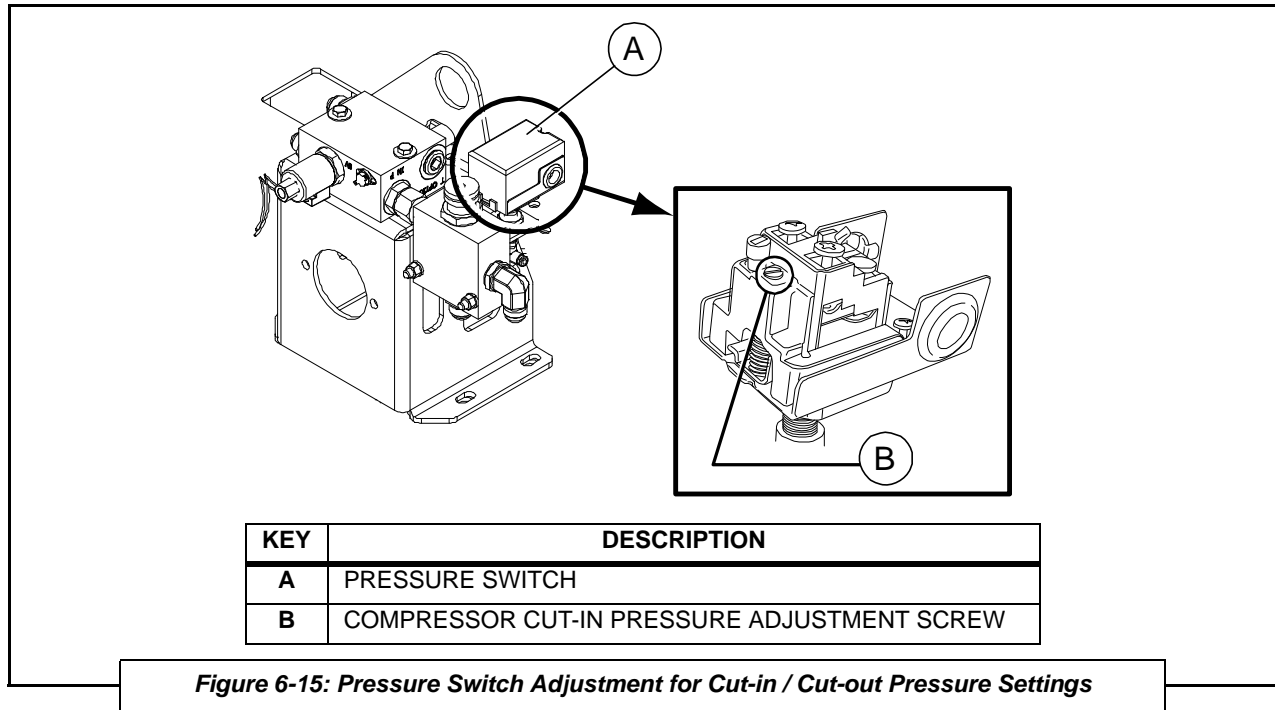

The **Cut-out pressure** is defined as the pressure in which the compressor stops pumping. When the pressure in the air tank rises above this pressure the compressor is signaled to stop pumping.

Pressure settings for both the minimum and maximum rated capacity levels for this machine are adjusted at the factory before shipping, and should not need to be adjusted. However, a situation may occur where it is necessary to manually adjust or reset either or both of these settings. For such cases, consult **Figure 6-15**, and the following procedure:

NOTE

There must be a minimum of 25 psi difference between the cut-in and cut-out pressures for the system to operate properly.

TOOLS NEEDED

Screwdriver

REPLACEMENT PART(S)

Not Applicable

WARNING

Pressure settings (both minimum and maximum) are pre-secured within the rated capacity levels for this machine at the factory before shipping. However, it may be necessary to manually adjust. **NEVER** adjust the pressures beyond the recommended or rated capacity specified for the machine.

1. Locate the air pressure control switch [A] at the rear-side of the generator support bracket. Remove the cover-retaining screw fastening the cover to the switch, and remove the cover.
2. To adjust the compressor pressure, turn the cut-in pressure adjustment screw [B] clockwise to increase the pressure and counterclockwise to lessen the pressure.

NOTE

Vanair® recommends that the air compressor and generator serpentine belts both be changed at the same time even if only one of the belts is in need of being changed.

NOTE

Proper alignment of all pulleys on the serpentine belt is crucial. A chirping or squeaking sound, noticeable after replacing the belts, may indicate an alignment problem. Always inspect and replace the belts as recommended in the maintenance section of this manual.

Misalignment of the v-belts can cause unnecessary jumping and wear of the belt, resulting in the belt coming off.



WARNING

Never operate the machine with the access door removed.

NOTE

If new belts are installed, recheck the tension after 10-20 hours of operation, and adjust if necessary.

3. After making your adjustments, position and re-fasten the cover to the pressure switch body with the cover retaining screw.
4. Close the hood, and cycle the compressor several times to ensure the correct pressures are set.
5. If additional adjustments are needed, repeat steps one through four until the correct pressures are set.

6.6.14 REPLACING AND RE-TENSIONING THE SERPENTINE DRIVE BELTS

The compressor and generator are driven by the motor using two belts. You may find that over time they become loose and need to be tightened. The proper tension can be determined by using a tension tester to measure the deflection from a given force.

6.6.14.1 RE-TENSIONING THE AIR COMPRESSOR SERPENTINE DRIVE BELT

Consult *Figure 6-16*, and the following procedure.

TOOLS NEEDED	REPLACEMENT PART(S)
Wrench - Size 6mm Hex Head	Not Applicable
Torque Wrench, 1/2" Drive	

1. With the machine off and the ignition key removed, open and remove the front panel.
2. Loosen the four tensioner plate bolts [A] mounting the tensioner plate [C] to the compressor only enough to allow tensioner plate to rotate/slide along the grooves in the plate while still in position (**DO NOT** remove).
3. Use a 1/2" drive torque wrench applied to the square tensioning hole [D] to manually rotate the plate/idler about the loosened, but anchored, mounting bolt. Apply torque of 51 ft-lbs.
4. Once a position is achieved that accounts for a satisfactory tension in the belt, torque the four (4) tensioner plate bolts [A] to 12 ft-lbs (16.3 Nm) to secure the tensioner into position.

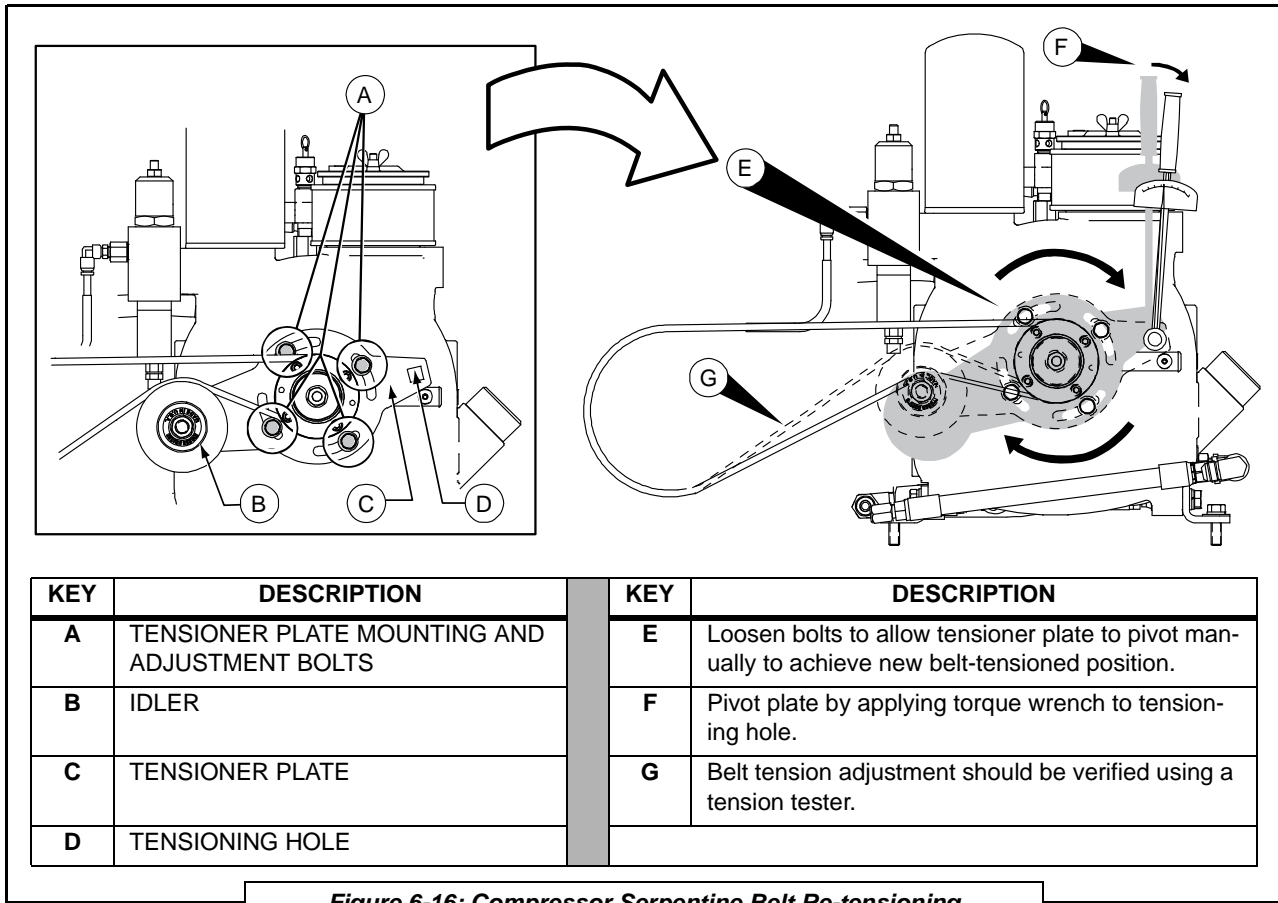

6.6.14.2 REPLACING THE AIR COMPRESSOR SERPENTINE DRIVE BELT

To replace the air compressor serpentine belt consult **Figure 6-17** and the following procedure:

TOOLS NEEDED	REPLACEMENT PART(S)
Socket Wrench - Size 6 mm Hex Head (for Tensioner Plate Bolts)	Serpentine Belt No. DR27584
Torque Wrench, 1/2" Drive	
Ratchet, 1/2" with Extension	

1. With the machine off and the truck off, open and remove the access panel.
2. Position and route the new air compressor serpentine belt as shown in **Figure 6-17**,

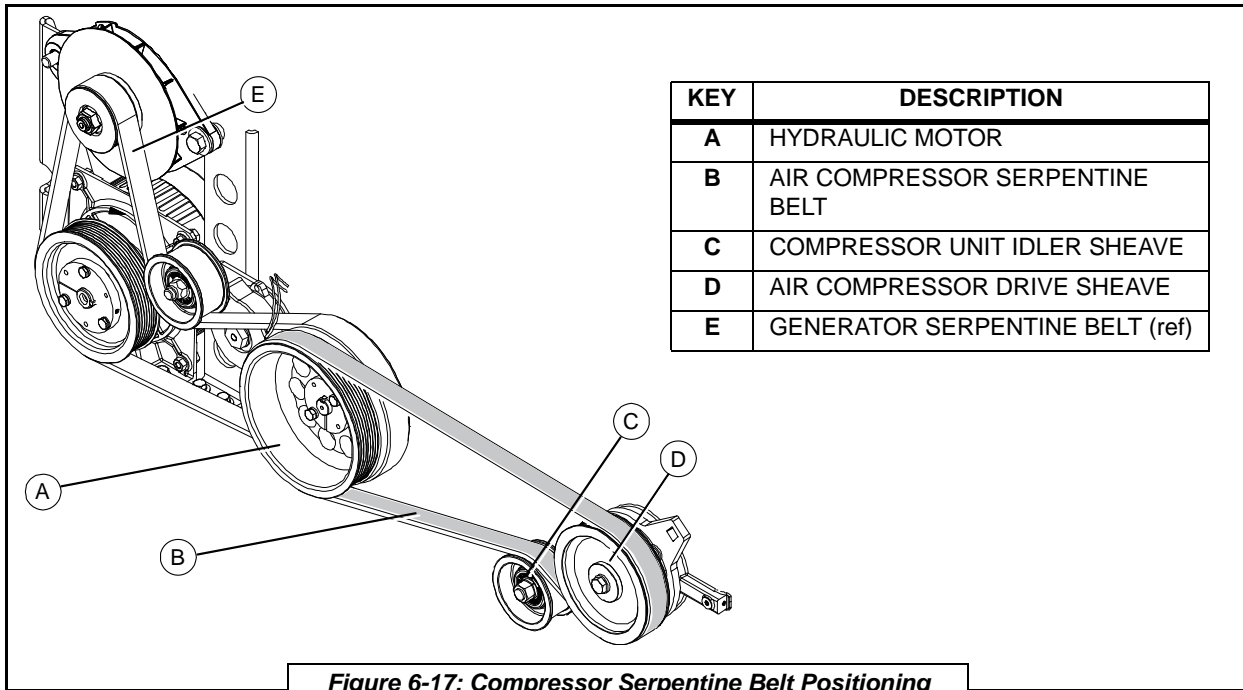

making sure that it goes on the outside of the double sheave track on the motor pulley.

NOTE

After replacing the serpentine belt, the belt will need to be checked for proper tension. Consult Section 6.6.15.1 on how to check and adjust the air compressor serpentine belt tension.

6.6.14.3 RE-TENSIONING THE GENERATOR SERPENTINE BELT

To re-tension the generator serpentine belt, consult **Figure 6-18** and the following procedure:

TOOLS NEEDED	REPLACEMENT PART(S)
Wrench - Size 3/8"	Not Applicable
Tension Tester	

1. With the machine off and the truck's ignition key removed, open and remove the front panel.

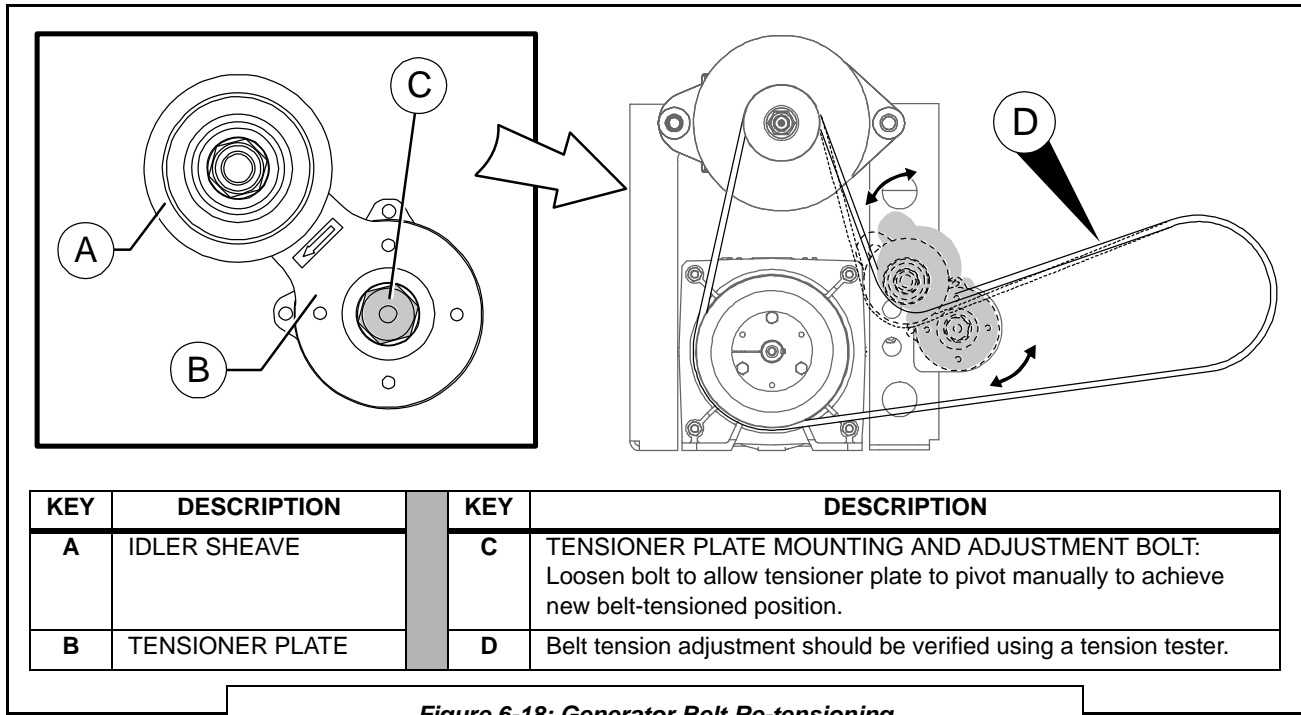

Figure 6-18: Generator Belt Re-tensioning

2. Locate the generator belt idler sheave [A] on the generator tensioner plate [B]. Loosen, but do not remove, the tensioner plate mounting and adjustment bolt [C]. Loosen enough to allow the tensioner plate to pivot while still retaining belt path position.

Vanair® recommends rotating the tensioner plate to its maximum position.

3. Once the position is achieved that accounts for a satisfactory tension in the belt, torque the bolt [C] to 12 ft-lbs. (16.3 Nm) to secure the tensioner plate [B] into position.

6.6.14.4 REPLACING THE GENERATOR SERPENTINE DRIVE BELT

TOOLS NEEDED
Wrench - Size 5/16" (for Tensioner Bolt)
Tension Tester
Socket Wrench - Size 3/4"

REPLACEMENT PART(S)
Serpentine Belt No. DR62184

NOTE
Vanair® recommends that the air compressor and generator serpentine belts both be changed at the same time even if only one of the belts is in need of being changed.

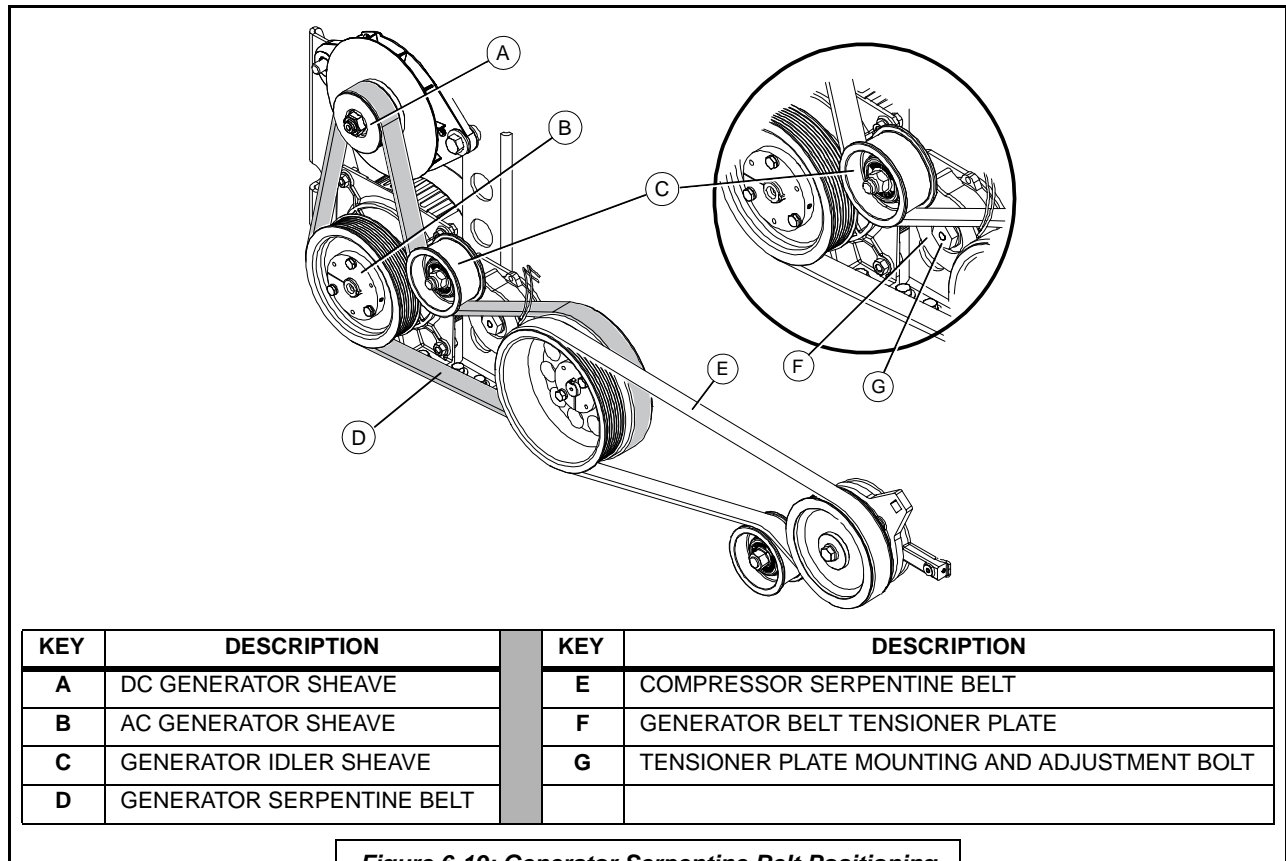

Figure 6-19: Generator Serpentine Belt Positioning

To replace the generator serpentine belt consult **Figures 6-19**, and the following procedure:

1. With the machine off and the truck's ignition key removed, open and remove the front access panel.

After removing the air compressor serpentine belt ([F] in **Figure 6-19**; refer to **Section 6.6.15.2** for compressor serpentine belt removal), The worn generator serpentine belt can now be replaced. Refer to **Figure 6-19** and the following steps:

2. Using a 3/4" socket wrench on tensioner plate bolt [H], pivot the belt tensioner [G] to relieve enough tension on the sheave [C] in order to remove the belt [D] - **remove** belt [D].
3. Position and route the new generator serpentine belt as shown in **Figure 6-19**.
4. Replace the compressor serpentine belt (refer to **Section 6.6.15.2**).

5. At this point the belt will need to be checked for proper tension. Consult **Section 6.6.15.3** on how to re-tension the generator serpentine belt, and **Section 6.6.15.1** to re-tension the compressor serpentine belt.

NOTE

Compressor belt goes on the outer track of the motor sheave; generator belt goes on the inner track.

6.7 SERVICING THE SYSTEM FUSES AND CIRCUIT BREAKERS

Consult **Figure 6-20** for the location of the DC welder generator fuse, the location of the Power System fuses, and the location of the motor fuse.

6.8 STORAGE AND INTERMITTENT USE

System Component or Part Group Task	Manual Section	Location
Storage and Intermittent Use	6.8	page 99
Intermittent Use	6.8.1	page 99
Long-term Storage	6.8.2	page 99

 **DANGER**

Fuses will need to be replaced if they are blown when tripped. When changing any fuse, or dealing directly with any function of the electrical system maintenance, always be aware of the safety warnings given in **Section 1, Safety**.

6.8.1 INTERMITTENT USE

If the unit is not used very regularly always treat the fuel with a fuel stabilizer.

Check all belts and hoses for signs of deterioration such as visible surface cracks, stiffness or discoloration.

NOTE

Replacement fuses can sometimes be found at local vendor carriers, such as automobile supply stores, hardware stores, etc.

6.8.2 LONG TERM STORAGE

Disconnect the battery cable that is connected to the positive (+) side of the battery.

 **CAUTION**

Parts can wear over time. Do not operate with worn equipment; replace as needed.

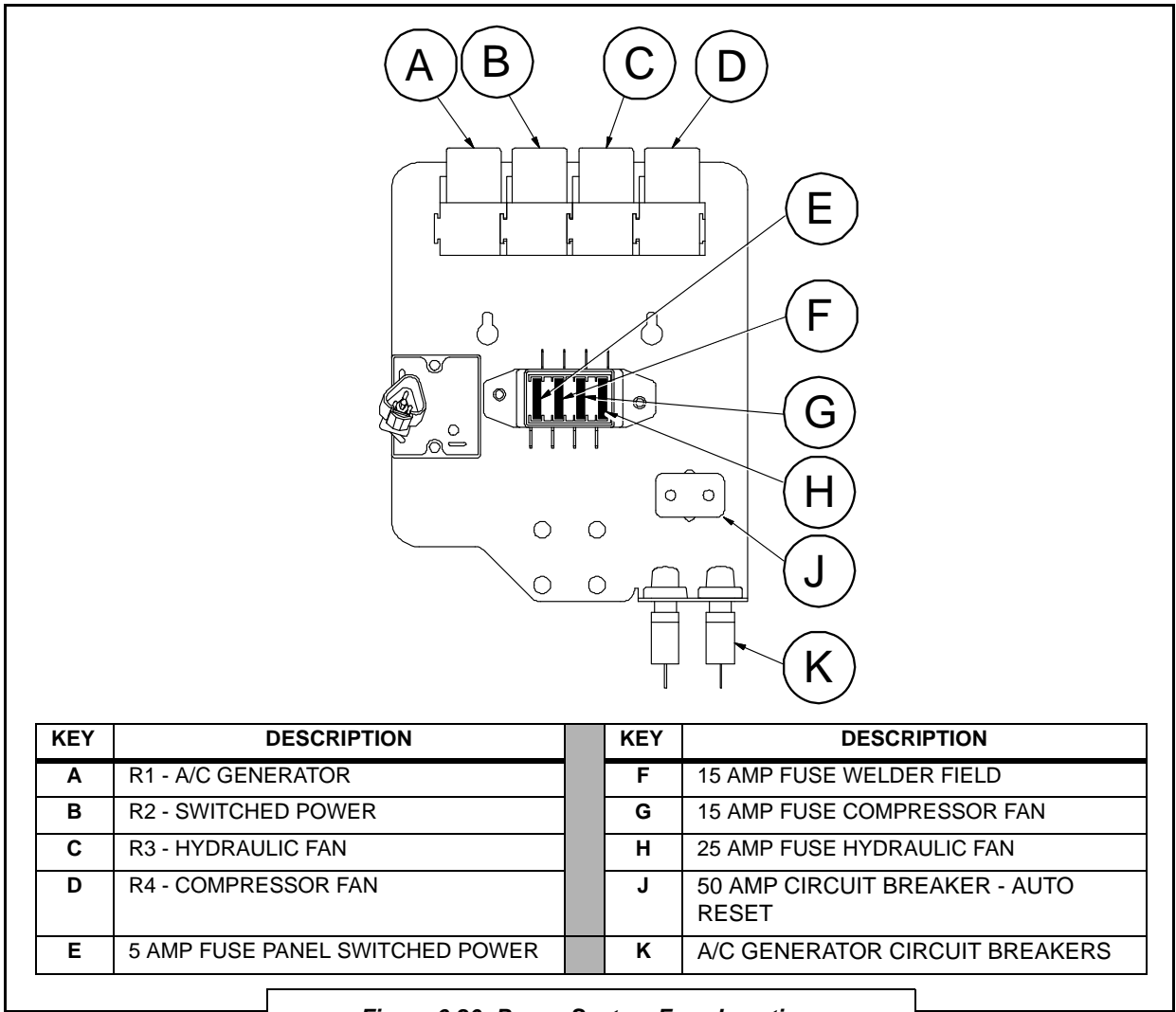

Figure 6-20: Power System Fuse Locations

SECTION 7: TROUBLESHOOTING

7.1 GENERAL INFORMATION

The information contained in this section has been compiled from years' worth of information gathered from the field. It contains symptoms and usual causes for the most common types of problems that may occur. All available data concerning the trouble should be systematically analyzed before undertaking any repairs or component replacement.

A visual inspection is worth performing for almost all problems and may avoid unnecessary additional damage to the machine. The procedures which can be performed in the least amount of time and with the least amount of removal or disassembly of parts, should be performed first. Adherence to a routine maintenance regimen will minimize the occurrence of many common problems. Refer to **Section 6.3, Maintenance Schedule Table** for a typical maintenance regimen program.

Although Vanair® strives to anticipate situations that may occur during the operation life of the machine package, the **Troubleshooting Guide** may not cover all possible situations. Be aware that additional troubleshooting information may be found in other sources such as the Engine Operator's Manual and the Generator Operator's Manual. Should the situation remain unresolved after exhausting available sources, contact the Vanair Service Department at:

Phone: 800-526-8817 (toll free)

Phone: 219-879-5100, ext. 400

Fax: 219-879-5335

NOTE

When contacting the Vanair Service Department, please have machine serial number on hand to quickly expedite service. See *Figures W-1 (machine) and/or W-2 (compressor unit)* in the *Warranty Details Section* for serial plate locations.

 **WARNING**

DO NOT operate any of the Air N Arc 300 Serie's functions if there is a known unsafe condition. Disable the equipment by disconnecting it from its power source. Install a lock-out tag to identify the equipment as inoperable to other personnel to prevent accidental application.

 **WARNING**

Before starting, performing maintenance, or replacing parts, relieve system pressure by opening the air tank drain/vent valve. Carefully open cap to relieve compressor pressure.

Refer to Figure 7-1. Open fill cap SLOWLY (contents under pressure) to make sure all pressure has been relieved.

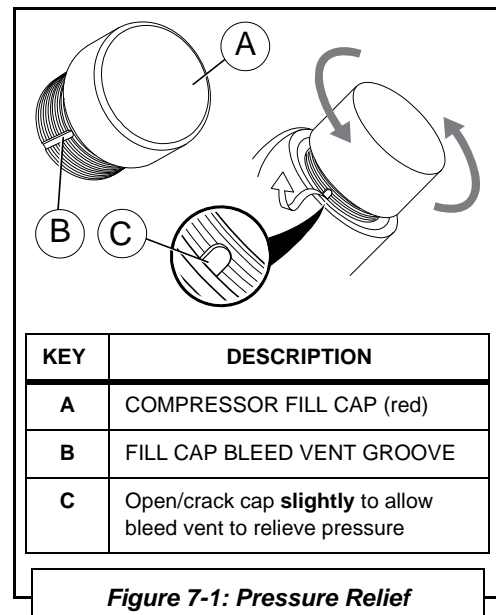

7.2 TROUBLESHOOTING GUIDE

Fault/Malfunction	Possible Cause	Corrective Action
COMPRESSOR		
Compressor overheats This condition will cause a compressor shutdown and compressor fault light to turn on. Before restarting the compressor, determine the cause for overheating.	Low compressor oil level	Check oil level and refill to proper level if necessary (ensure machine is parked on a level surface). Refer to Section 6.6.3, Checking the Compressor Oil.
	Obstructed fluid cooler	Clear debris/dirt from cooler core/flush shroud.
	Obstructed cooler fins	Clear/clean if required. Refer to Section 6.6.11.
	Insufficient air flow over cooler	Check for obstructions (frame, body, etc.) to cooling air flow.
	Defective temperature switch	Check switch; replace if necessary.
	Compressor oil filter plugged	Replace filter; refer to Section 6.6.4, Replacing the Compressor Oil Filter Element.
	Input rpm too high	Adjust to proper setting; refer to Section 6.6.12, Adjusting the Motor Speed.
	Fan not operating	Low oil; check oil level and refill to proper level if necessary (ensure machine is parked on a level surface). Refer to Section 6.6.3, Checking the Compressor Oil.
Compressor shuts down with air demand present	Compressor temperature switch opening	Check compressor oil level. Replenish if necessary.
	Restricted cooling air intake	Reposition machine.
	Fan not operating	Low oil; check oil level and refill to proper level if necessary (ensure machine is parked on a level surface). Refer to Section 6.6.3, Checking the Compressor Oil.
		Belt slip on hydraulic pump. Refer to Section 6.6.14 or Section 6.6.14.1.
	Compressor oil filter plugged	Replace filter; refer to Section 6.6.4, Replacing the Compressor Oil Filter Element.
	Improper speed	Check hydraulic GPM and pressure.
<i>Continued on next page</i>		

7.2 TROUBLESHOOTING GUIDE		
Fault/Malfunction	Possible Cause	Corrective Action
COMPRESSOR (CONTINUED)		
Compressor shuts down with air demand present (continued)	Plugged or restricted cooler core	Flush cooler. Consult the Vanair Service Department for assistance in cleaning/flushing the cooler core.
	Contaminated cooler fins	Clean cooler fins. Refer to Section 6.6.11, Inspecting the System Coolers.
Compressor will not build up pressure	Pressure switch out of adjustment	Reset pressure switch. Refer to Section 2.2.7, Adjustable Pressure Switch, and Section 6.6.13, Adjusting the Pressure Setting. Replace if switch continues to deviate from setting.
	Low compressor oil level	Check oil level and refill to proper level if necessary (ensure machine is parked on a level surface). Refer to Section 6.6.3, Checking the Compressor Oil.
	Air demand too high	Check for leaks and take corrective action.
		Check air tools for wear, damage, or malfunctions. Replace or repair.
	Compressor capacity too low to accommodate demand	Substitute larger capacity compressor system.
	Compressor air filter plugged	Check air filter. Replace if necessary; refer to Section 6.6.1, Compressor Air Filter.
	Defective pressure switch	Replace pressure switch.
	Control throttle solenoid stuck	Replace throttle solenoid.
	Belt(s) slipping	Re-situate and adjust belt tension, or replace belt if necessary. Consult Section 6.6.14, Replacing and Re-tensioning the Serpentine Belts
	Pressure gauge is malfunctioning	Check pressure gauge function/control line routing: adjust, repair or replace as necessary.
	Check for proper operation with an auxiliary air source. Replace if necessary	
<i>Continued on next page</i>		

7.2 TROUBLESHOOTING GUIDE		
Fault/Malfunction	Possible Cause	Corrective Action
COMPRESSOR (CONTINUED)		
Compressor will not build up pressure (continued)	Inlet valve fails to open or is frozen shut.	Repair/replace inlet valve. Refer to Section 6.6.2, Repairing the Air Inlet Valve . Order inlet valve repair kit—see Table 9A: Recommended Spare Parts List .
Compressor system over-pressures This condition will cause a compressor shutdown, and a fault light will turn on. Before restarting the compressor, determine the cause of the over-pressure. May also cause the relief valve to open.	Pressure switch setting too high	Reset pressure switch. Refer to Section 2.2.7, Adjustable Pressure Switch , and Section 6.6.13, Adjusting the Pressure Setting . Replace if switch continues to deviate from setting.
	Pressure switch malfunction	Check for operation/damage: repair or replace.
	Unload solenoid valve defective	Replace solenoid valve.
	Leak in air control line	Check for leaks and take corrective action.
	Restriction in control line	Clean if soiled; if ice is present, clear and remove.
	Damaged/kinked control line	Check line for damage (wear, kinks, etc.). Re-route, re-tie or replace if necessary (refer to Appendix A, A.6 Hose Installation Guide for assistance in running or checking hose lines).
	Control line connections are not properly seated/poor connection quality	Check lines for proper seating/ensure line ends have been cut cleanly and are square (DO NOT use wire cutters: use a loom cutting tool or a clean, sharp razor blade).
	Inlet valve Teflon “O” ring popped out of groove	Replace “O” ring: Refer to Section 6.6.2, Repairing the Air Inlet Valve . Order inlet valve repair kit—see Table 9A: Recommended Spare Parts List .
	Damaged inlet seat	Rebuild inlet assembly.
	Inlet valve piston is stuck in down position.	Check for proper operation with an auxiliary air source—replace or rebuild inlet valve. Consult Section 6.6.2 .
Compressor shaft seal is leaking	Replace shaft seal with available kit. Refer to Section 6.6.7 .	
Minimum pressure/check valve is malfunctioning	Rebuild or replace check valve: Refer to Section 6.6.10 ; order check valve repair kit—see Table 9A: Recommended Spare Parts List .	
<i>Continued on next page</i>		

7.2 TROUBLESHOOTING GUIDE		
Fault/Malfunction	Possible Cause	Corrective Action
COMPRESSOR (CONTINUED)		
Compressor system over-pressures (continued)	Pressure gauge is malfunctioning	Check gauge for proper operation; replace if necessary and check controls.
No service air output	If equipped, OSHA valve/velocity fuses, not functioning properly	Reset or replace OSHA valve.
Low service air output (See also <i>Compressor will not build up pressure</i>)	Clogged compressor air filter	Check air filter. Replace if necessary; refer to Section 6.6.1, Compressor Air Filter .
	Solenoid valve sending continuous signal to inlet valve	Rebuild or replace solenoid valve if defective. Refer to Section 6.6.8
	Incorrect compressor speed	Adjust speed. Refer to Section 6.6.12 .
	Minimum pressure valve stuck	Rebuild minimum pressure valve
Compressor stalls	Pressure switch setting too high	Adjust pressure switch setting. Refer to Section 2.2.7, Adjustable Pressure Switch , and Section 6.6.13 Adjusting the Pressure Setting . Replace if switch continues to deviate from setting.
	Speed is set too low	Check hydraulic pressure and GPM
System operating pressure below specified minimum	Air demand too high	Check air tools for wear, damage, or malfunctions. Replace or repair.
	Compressor capacity too low to accommodate demand	Substitute larger capacity compressor system.
	System leaks or is damaged	Inspect for leaks. Repair and/or replace damaged parts as necessary. Use Section 9, Illustrated Parts List to visually confirm/identify any part that needs to be replaced before ordering part.
	Pressure switch set too low/malfunction	Adjust pressure switch setting. Refer to Section 2.2.7, Adjustable Pressure Switch , and Section 6.6.13, Adjusting the Pressure Setting . Replace if switch continues to deviate from setting.
	Input rpm too low	Adjust to proper setting.
	Inlet valve contaminated or fails to open.	Remove valve and clean piston; repair/replace inlet valve. Refer to Section 6.6.2, Repairing the Air Inlet Valve . Order inlet valve repair kit—see Table 9A: Recommended Spare Parts List .
<i>Continued on next page</i>		

7.2 TROUBLESHOOTING GUIDE		
Fault/Malfunction	Possible Cause	Corrective Action
COMPRESSOR (CONTINUED)		
Excess amount of oil in air discharge	Machine not on level surface	Move machine to level surface.
	Compressor oil level too high	The correct oil level is between the bottom of the oil port threads (low level) to the top lip of the port's threads (high level). Drain excess oil to correct level.
		Tank not positioned with the drain at its lowest point. Reposition machine. NOTE: Machine must be operated while on a level surface in order for proper compressor oil circulation throughout the system.
	Scavenger system not operating	Inspect scavenger line for obstructions or leaks. Replace if necessary.
	Coalescer element plugged or damaged	Replace the coalescer element. Consult Section 6.6.6, Replacing the Spin-on Air/Oil Coalescer . Order replacement coalescer element—see Table 9A: Recommended Spare Parts List .
Excessive moisture in the compressed air	Moisture accumulating in air tank	Drain water from air tank. Refer to Section 6.6.9, Draining the Air Tank .
	Compressor not running long enough	Run compressor long enough to get hot.
WELDER		
Welder and battery charger behave erratically	Connection cables or receptacles are soiled/contaminated	Check for twisted cables and/or soiled/contaminated or loose receptacle connections.
		Untwist and/or straighten out any suspected cable tensions. Carefully wipe off any contaminants to receptacle connectors before re-connecting. Replace any worn or damaged cables or receptacles. Contact Vanair® Mfg., Inc. Service Department if behavior persists.
	Connections not making contact	Correct connection at lug and clamp
	Belt slipping	Re-tension or replace belt. Refer to Section 6.6.14.3, Re-tensioning the Generator Serpentine Belt , and Section 6.6.14.4, Replacing the Generator Serpentine Belt .
	Welding function is not drawing enough operating power	If running more than one function simultaneously, turn off competing function.
<i>Continued on next page</i>		

7.2 TROUBLESHOOTING GUIDE		
Fault/Malfunction	Possible Cause	Corrective Action
WELDER (CONTINUED)		
No welder output	Fuse at welder field blown	Replace the welder field fuse. Refer to Section 6.7, Servicing the System Fuses and Circuit Breakers
	Low battery voltage	Check/replace battery
No welder output in CC mode	Bad ground connection	Make sure of connection. Clean welding surface.
BATTERY BOOSTER/CHARGER		
No output (Note: Must be hooked to a battery for output)	Bad connection	Check all connections
	Battery damaged or voltage too low	Replace battery
	Fuse at generator blown	Replace fuse. Refer to Section 6.7, Servicing the System Fuses and Circuit Breakers
AC GENERATOR		
No AC generator output	Serpentine belt slipping or damaged	Re-situate and adjust belt tension, or replace belt if necessary. Consult Section 6.6.14, Replacing and Re-tensioning the Serpentine Belts . Order replacement belt—see Table 9A: Recommended Spare Parts List .
	Circuit breaker tripped	Reset circuit breaker (two located on machine and two located on panel)
	Faulty AC generator relay	Check; replace if necessary.
	Faulty capacitor	Check; replace if necessary.
Low AC voltage	Motor speed too low	Check Hz and adjust PTO
	Weak or faulty capacitor	Check; replace if necessary.
	Belt slipping	Check tension or replace belt if necessary. Consult Section 6.6.14, Replacing and Re-tensioning the Serpentine Belts . Order replacement belt—see Table 9A: Recommended Spare Parts List .
	Cap mF too small	Check cap mF
High AC voltage	Motor speed too high	Check Hz and adjust PTO
	Cap mF too large	Check cap mF

BLANK PAGE

SECTION 8: DIAGRAMS

8.1 GENERAL INFORMATION

The diagrams located in this section of the manual are designed to assist the service technician with troubleshooting any problems that may arise while operating the All-In-One Power System within its intended use.

The flow schematic and wiring diagram should be used together when identifying any potential problems. They are laid out in a format that is designed to be easy to read for the end user or a service technician.

NOTE
<p>For machine measurement specifications refer to <i>Section 4.10 Installation and Dimensions Diagram (Part 1 and 2)</i>.</p>

8.2 WIRING DIAGRAM - AIR N ARC 300 SERIES (HYDRAULIC)

WIRING INFORMATION	
SYSTEM	DESCRIPTION
CONTROLS	1 GROUND
	2 12V: CONSTANT
	3 12V: SWITCHED INT. PNL.
	4 12V: SWITCHED MACHINE
	5 12V: SWITCHED TRUCK
	6 SHUTDOWN
	7 HYD FAN
	8 TACH PICKUP
	9 HYD ENGAGE
WELDER	10 FIELD
	11 CABLE
	13 HALL EFFECT
	14 HALL EFFECT
COMPR.	15 COMPRESSOR
	17 TEMP (FAN)
	18 FAN
	20 HEATER
	21 COMPRESSOR UNLOAD
GEN.	22 CAPACITOR
	24 CAPACITOR
	25 GENERATOR
WELDER	30 CHARGE LOOKOUT

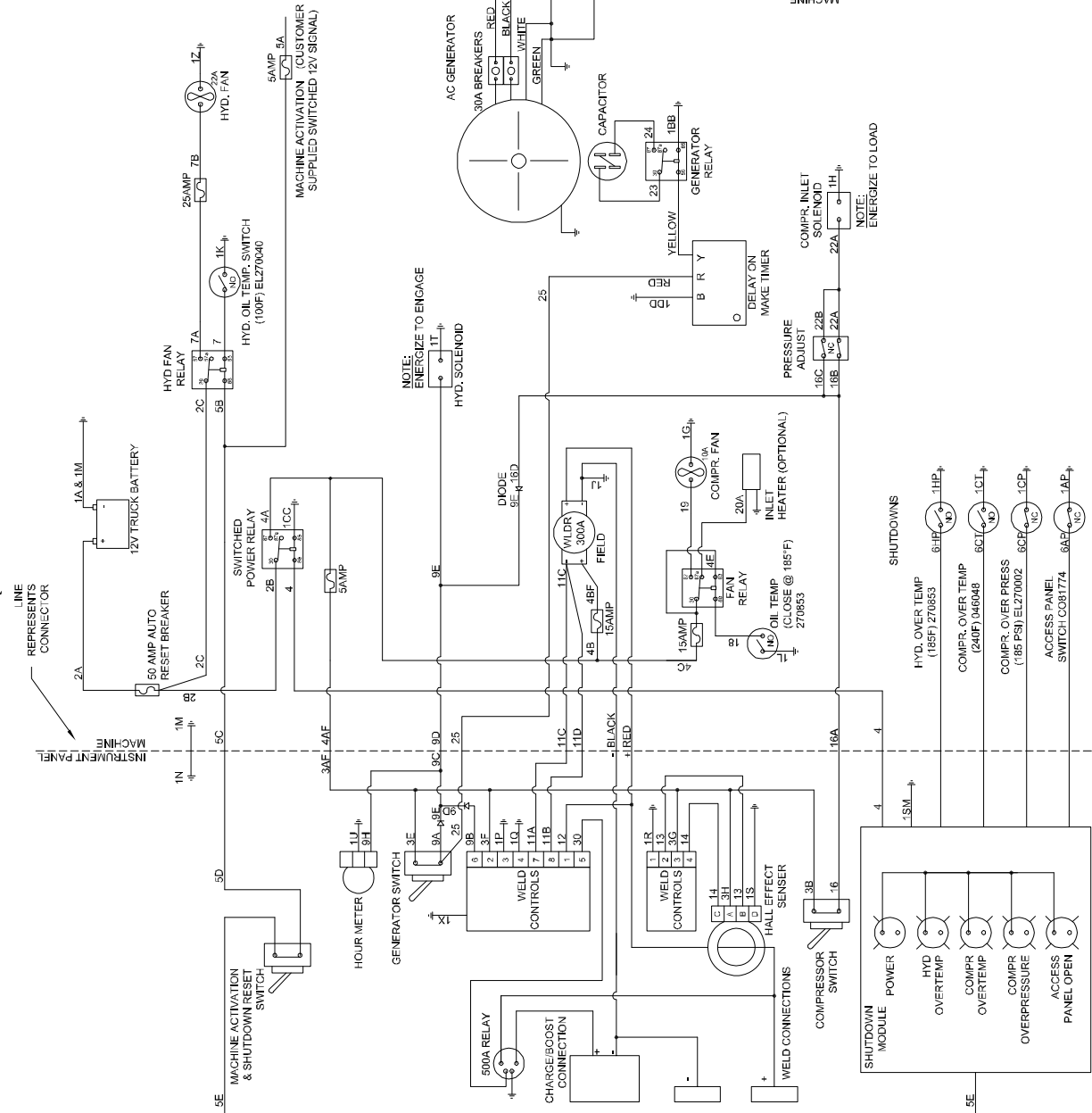

8.3 COMPRESSOR FLOW SCHEMATIC DIAGRAM

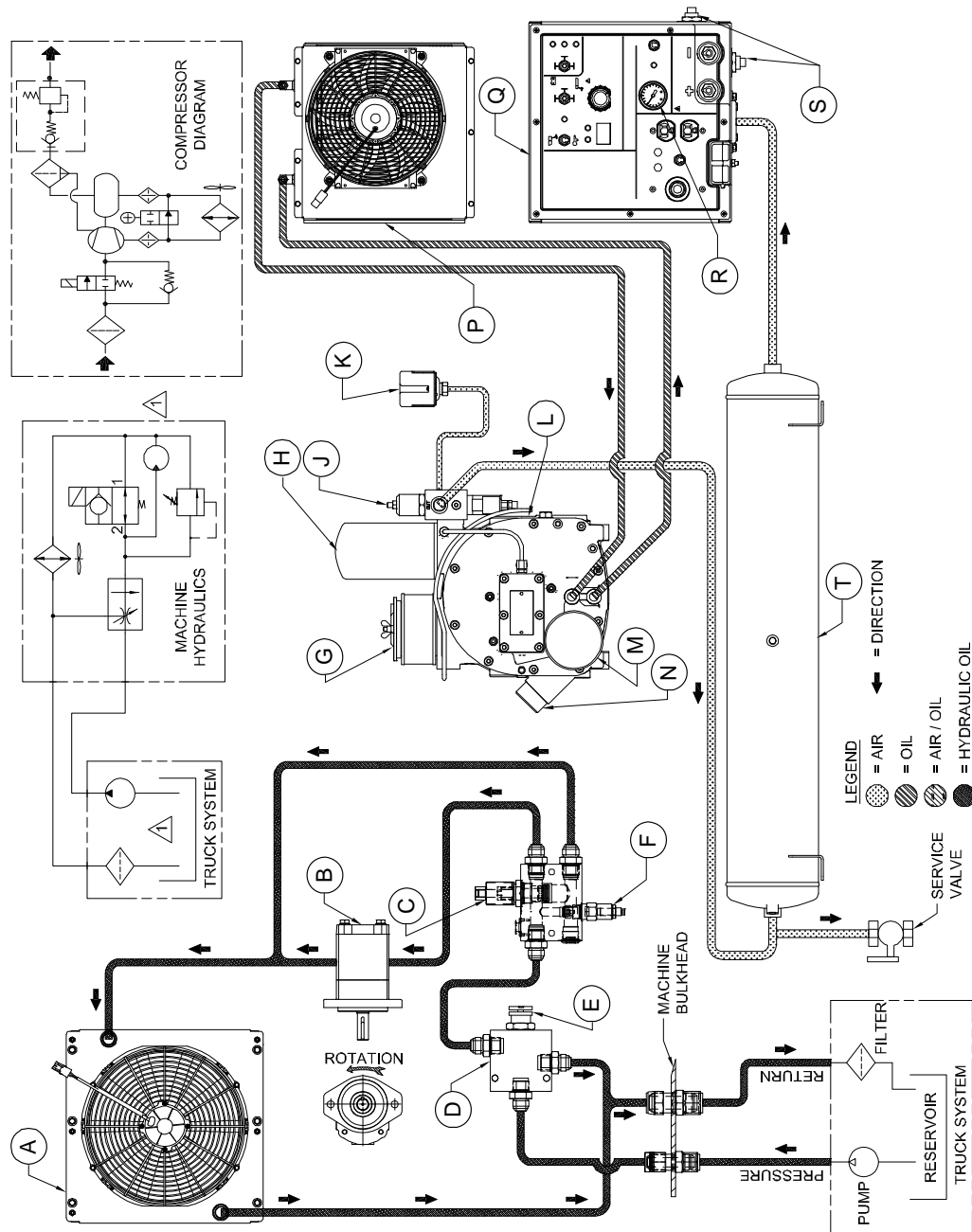

KEY	DESCRIPTION	KEY	DESCRIPTION
A	HYDRAULIC COOLER	K	PRESSURE SWITCH
B	HYDRAULIC MOTOR	L	COMPRESSOR
C	12V SOLENOID VALVE	M	OIL FILTER
D	FLOW CONTROL	N	OIL FILL
E	FLOW ADJUSTMENT	P	COMPRESSOR COOLER
F	PRESSURE RELIEF VALVE	Q	INSTRUMENT PANEL
G	AIR FILTER	R	TANK AIR PRESSURE
H	COALESCER	S	AIR OUT
J	MINIMUM PRESSURE SWITCH	T	AIR ACCUMULATOR TANK

BLANK PAGE

SECTION 9: ILLUSTRATED PARTS LIST

9.1 PARTS ORDERING PROCEDURE

Part orders should be placed through the distributor from whom the unit was purchased. If, for any reason parts cannot be obtained in this manner, contact the factory directly at the address or phone numbers below.

When ordering parts, always indicate the **Serial Number** of the machine package. This can be obtained from the Bill of Lading for the machine package, or from the compressor unit serial number plate. See **Figure 9-1** for location of machine package serial plate. Consult **Table 9A: Recommended Spare Parts List** on the next page for a listing of replacement parts.

VANAIR® MANUFACTURING, INC.

10896 West 300 N.

Michigan City, IN 46360

Telephone: (800) 526-8817

(219) 879-5100

Service Fax: (219) 879-5335

Parts Fax: (219) 879-5340

Sales Fax: (219) 879-5800

www.vanair.com

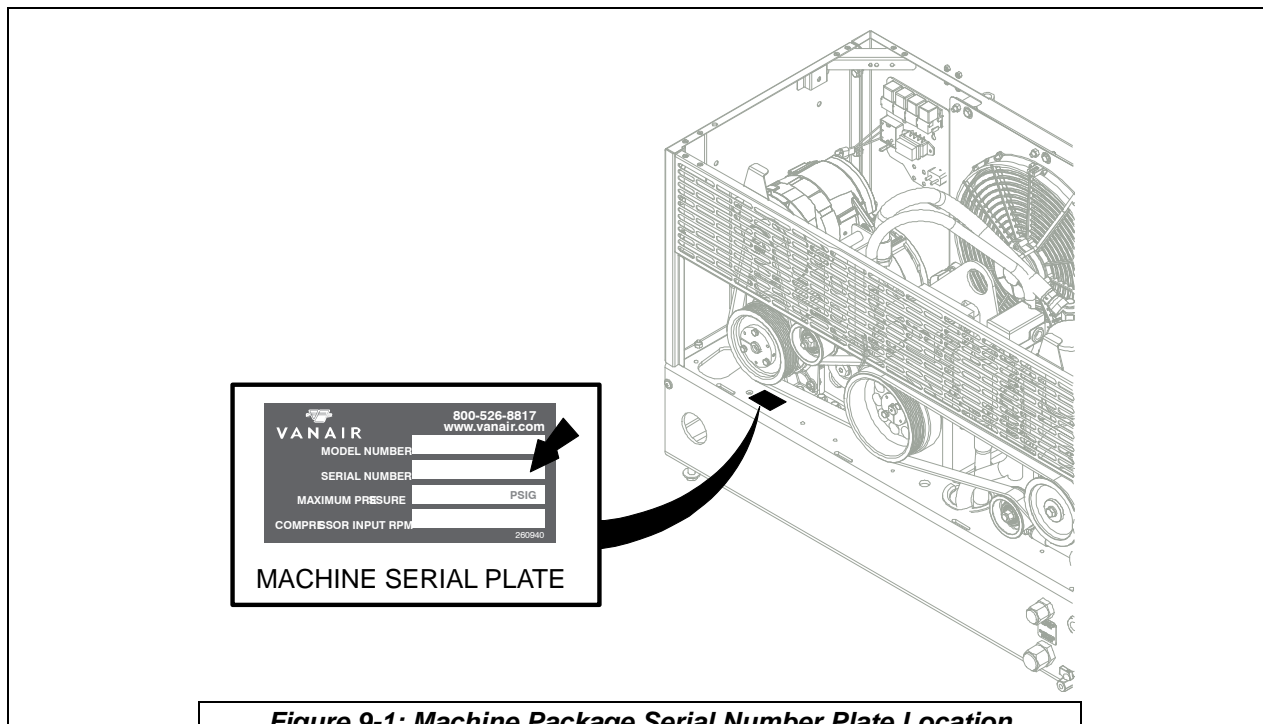

Figure 9-1: Machine Package Serial Number Plate Location

TABLE 9A: RECOMMENDED SPARE PARTS LIST					
KEY NO.	PART NUMBER	DESCRIPTION	QTY	IDENTIFICATION REFERENCE	
				SECTION	KEY NO.
ROUTINE/SCHEDULED MAINTENANCE ITEMS					
1	264626 - 1 Gal.	Vanguard™ Premium Oil [‡]	1 Gal.	-	-
2	254471	Element, Oil Filter (compressor)	1	Figure 6-6	A
3	264469	Element, Compressor Air Filter	1	Figure 6-2	C
4	264470	Element, Air/Fluid Separator Spin-on Style Coalescer	1	Figure 6-8	A
NON-ROUTINE MAINTENANCE ITEMS					
6	HY271406	Motor, Hydraulic (Fan)	1	9.9	#14
7	CO89649	Gauge, Air, Dry	1	9.7	#31
8	PR270548	Boot, Breaker	1	9.7	#51
9		Fuse, 5 Amp	1	Figure 6-20	E
10		Fuse, 15 Amp	2	Figure 6-20	F, G
11		Fuse, 25 Amp	1	Figure 6-20	H
12		Breaker, 50 Amp Auto-Reset	1	Figure 6-20	J
13	046048	Switch, 240 Deg F NO	1	9.3	#1
14	CO62617	Breaker, Circuit 20A	2	Figure 6-20	K
16	DR271456	Belt, Serpentine Compressor	1	9.3	#37
17	DR62184	Belt, Serpentine Generator	1	9.8	#26
19	270766	Kit, Compressor Shaft Seal Rebuild	1	Figure 6-9	-
20	270765	Kit, Minimum Pressure / Check Valve Rebuild	1	Figure 6-13	-
21	264154-102	Kit, Air Inlet Valve Rebuild	1	Figure 6-4	D
[‡] Use only Vanair® Vanguard™ Premium Synthetic Oil and Genuine Vanair Parts. Inspect and replace damaged components before operation. Substituting non-Vanguard™ Oil or non-genuine Vanair filter components WILL VOID THE COMPRESSOR WARRANTY!					

NOTE

For a complete list of available options, see Appendix A, Section A.5 Air N Arc 300 Series All-In-One Power System Available Options List

NOTE

If additional spare parts are being stored for future use, make certain that they are stored in proper containers that allow for protection against contamination, and kept in a clean area of moderate temperature reading. For information on storing the machine package for periods of non-use, consult Section 6.8.2, Long Term Storage.

NOTES

9.2 AIR N ARC 300 SYSTEMS ASSEMBLIES

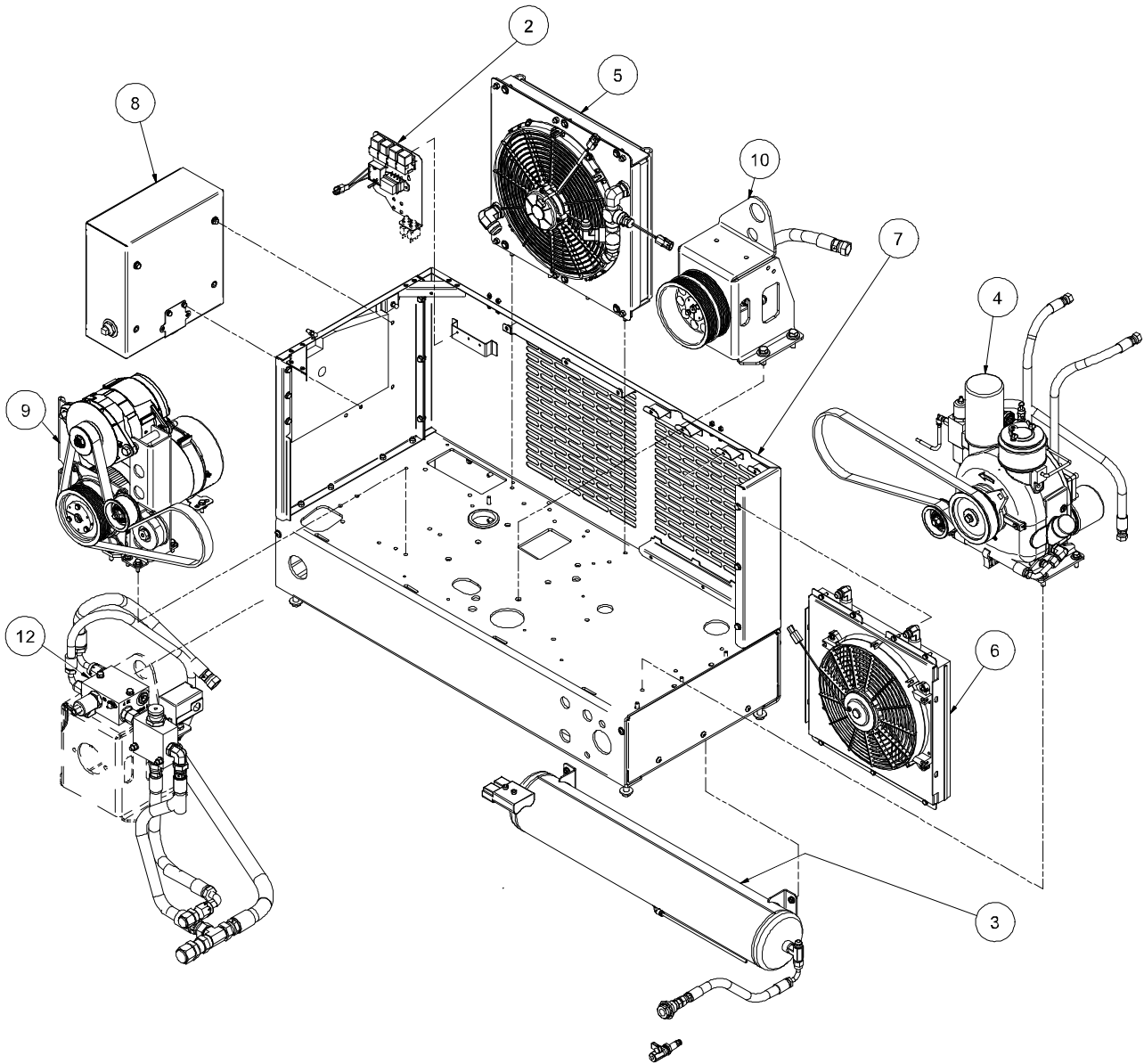

PA6130044_r1

9.2 AIR N ARC 300 SYSTEMS ASSEMBLIES

ITEM	DESCRIPTION	PART NUMBER	QTY
1	SCHEMATIC, FLOW ANA 300 HYDRAULIC	271384	1
2	HARNESS, MAIN MACHINE	EP271411	1
3	AIR STORAGE ASSEMBLY	PA6000027ID	1
4	ID, COMPRESSOR & PARTS	PA6010072ID	1
5	COOLING SYSTEM, ANA 300H	PA6020033ID	1
6	ID, COOLING SYSTEM COMPRESSOR	PA6020036ID	1
7	ID, FRAME & CANOPY	PA6030031ID	1
8	INSTRUMENT PANEL	PA6040027ID	1
9	ID, GENERATORS AND PARTS	PA6050012ID	1
10	ID, MOTOR & DRIVE PARTS	PA6100027ID	1
11	DECALS, ANA HYDRAULIC	PA6110001	1
12	ID, ASS'Y FLOW CONTROL	PA6120097ID	1
13	KIT, HOSE AND FITTING ANA 300 HYDRAULIC	TU271455	1

9.3 COMPRESSOR AND PARTS ASSEMBLY (1 OF 2)

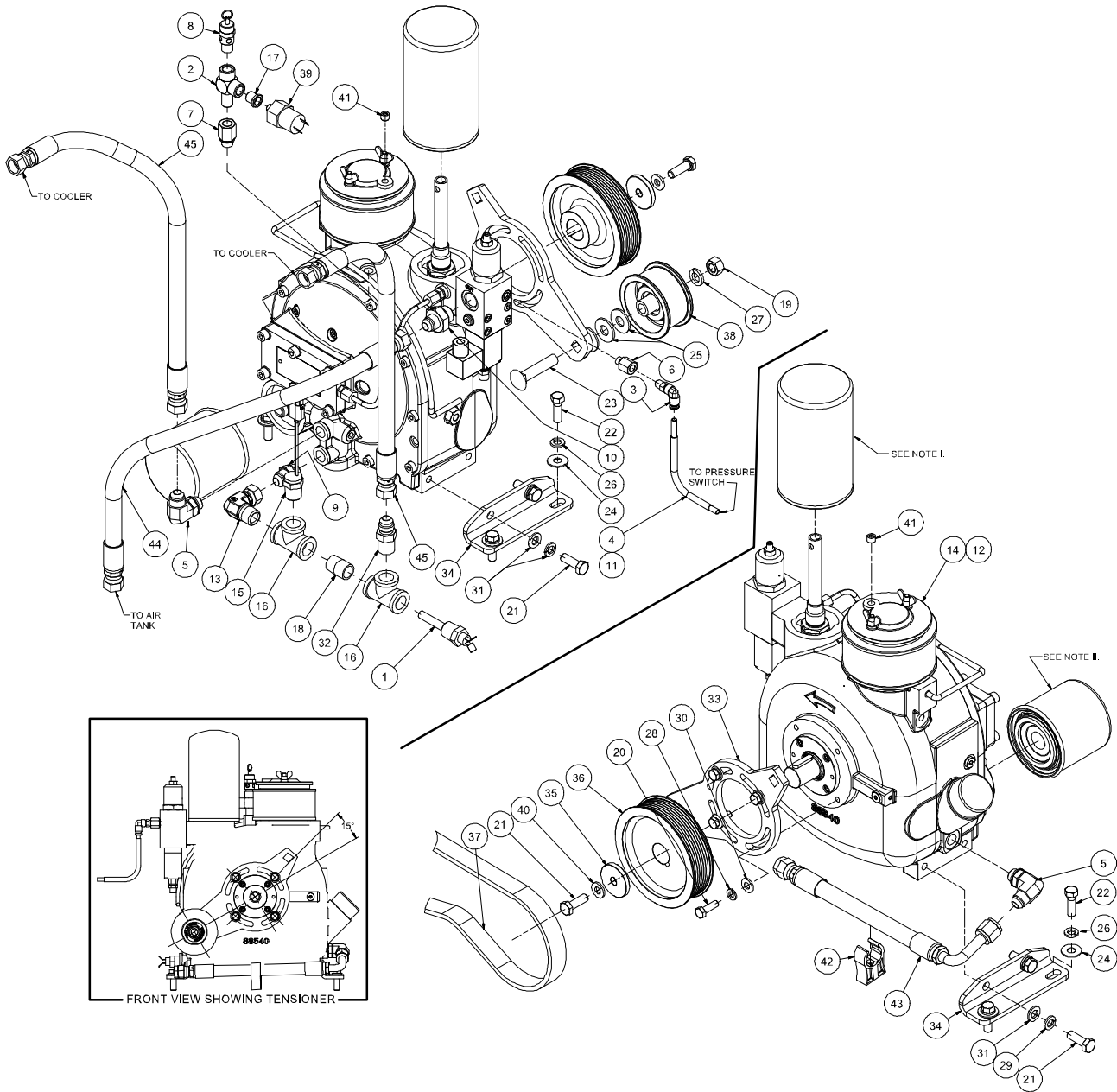

PA6010072ID_r1

9.3 COMPRESSOR AND PARTS ASSEMBLY (1 OF 2)

ITEM	DESCRIPTION	PART NUMBER	QTY
1	SWITCH, TEMP 240 DEG F N.O.	046048	1
2	TEE, MALE STREET 1/4 x 1/4 x 1/4	260402-102	1
3	ELBOW, 1/4T x 1/8P PUSH-ON	261309	1
4	LOOM, FLEX-GARD 1/4 ID x 3 FT	262751	1
5	ELBOW, 90 DEG. 1/2 MJIC x 3/8 MBSPP ADJ	263747-021	2
6	ADAPTER, FEMALE PIPE x BSPP 1/8	263748-001	1
7	ADAPTER, FEMALE PIPE x BSPP 1/4	263748-004	1
8	VALVE, RELIEF 200 PSI 1/4 NPT MALE	264232	1
9	ADAPTER, M-JIC 1/2 x BSPP 3/8	264312-007	1
10	ADAPTER, MJIC x MBSPP 1/2 x 1/2	264312-008	1
11	TUBING, 1/4 DIA., NYLON, 230 PSI X 3 FT	264480.	1
12	OIL, VANGUARD 3.5 QUARTS	264626	1
13	ELBOW, 1/2MPT x 1/2FJIC SWVL 90	268929-008	1
14	COMPR & PART VANAIR 31 EMC, 12VDC STD SHAFT	269761	1
15	SWITCH , TEMPERATURE (ELECTRIC)	270853	1
16	TEE, PIPE GALV 1/2	804415-020	2
17	BUSHING, RED STEEL 1/4 x 1/8	807600-005	1
18	NIPPLE, PIPE XS CLOSE 1/2	822208-000	1
19	NUT, HEX 1/2-13	825208-448	1
20	CAPSCREW, HEX M8 1.25 x 25mm	828008-025	4
21	CAPSCREW, HEX 10MM 1.5 x 30MM	828010-030	5
22	CAPSCREW, HEX GR8 3/8-16 x 1-1/4	829406-125	4
23	BOLT, CARRIAGE 1/2-13UNC x 2-1/2" LG.	829508-250	1
24	WASHER, FLAT 3/8	838206-071	4
25	WASHER, FLAT 1/2	838208-112	3
26	WASHER, LOCK 3/8	838506-094	4
27	WASHER, LOCK 1/2	838508-125	1
28	WASHER, LOCK METRIC M8	838808-200	4
29	WASHER, LOCK METRIC M10	838810-220	4
30	WASHER, FLAT METRIC M8	838908-180	4
31	WASHER, FLAT METRIC M10	838910-220	4

Continued on page 121

9.3 COMPRESSOR AND PARTS ASSEMBLY (2 OF 2)

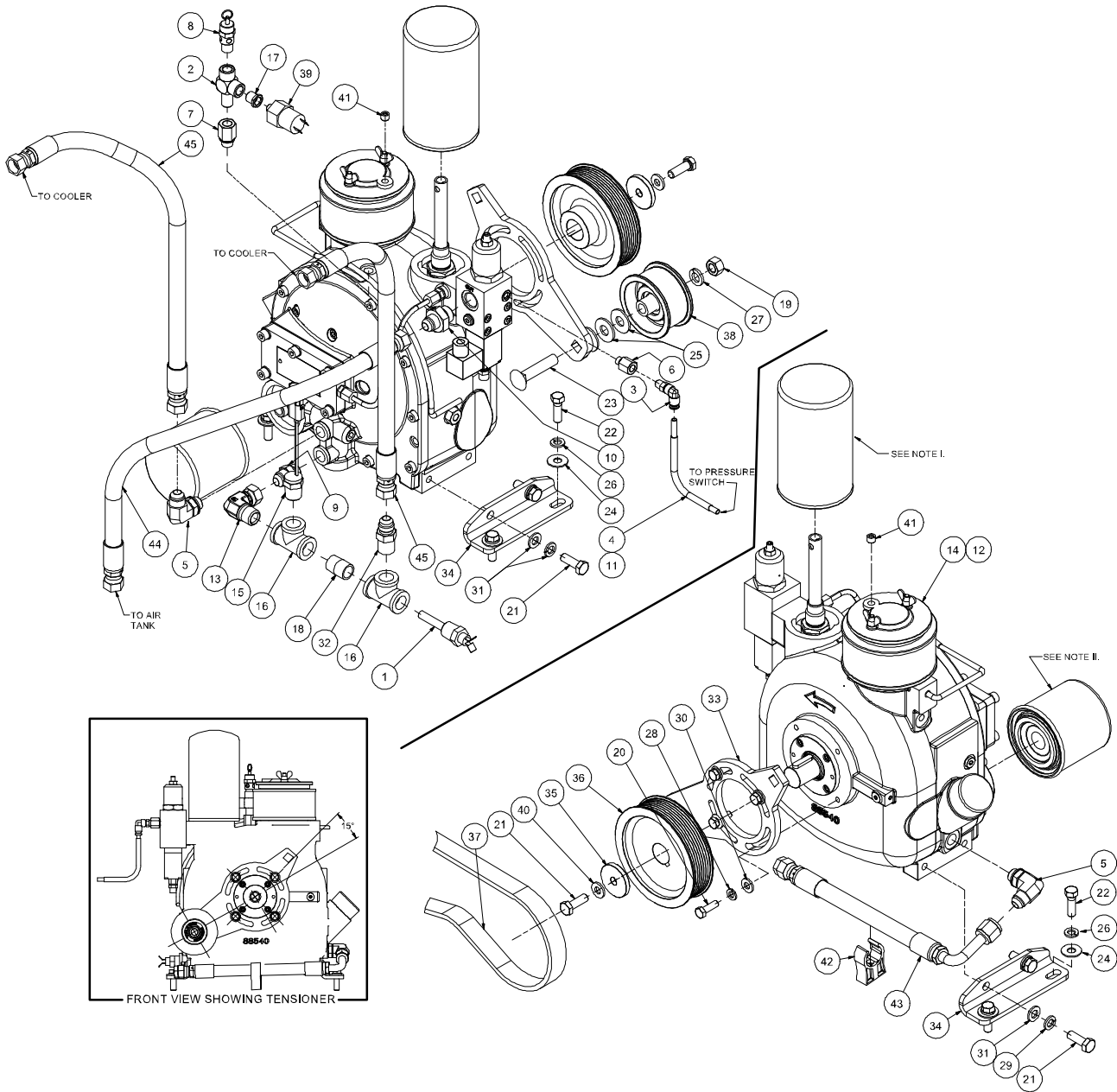

PA6010072ID_r1

9.3 COMPRESSOR AND PARTS ASSEMBLY (2 OF 2)

ITEM	DESCRIPTION	PART NUMBER	QTY
32	CONNECTOR, 37FL/MPT #08 x 1/2	860108-050	1
33	TENSIONER, AIR END	A1270372	1
34	BRACKET, COMPRESSOR MTG	A1270373	2
35	WASHER, SHEAVE COMPRESSOR	A1270884	1
36	SHEAVE, COMPRESSOR "8-GROOVE"	DR270371	1
37	BELT, SERPENTINE, 8 RIB x 55" LG EFFECTIVE LENGTH, BLACK RUBBER	DR271456	1
38	IDLER, 1.375 WIDTH, 3 3/8 DIA	DR46584	1
39	SWITCH, PRESSURE N.C. 185 PSI	EL270002	1
40	WASHER, 3/8ID X 13/16OD	FA49463	1
41	PIPE BRASS, PLUG, COUNTERSUNK 1/8" NPT	FI67437	1
42	CLIP, DRAIN HOSE HOLDER, 3/4	HA270218	1
43	HOSE, COMP'R DRAIN	TU271455-001	1
44	HOSE, COMPR TO AIR TANK	TU271455-004	1
45	HOSE, COMPR TO COOLER	TU271455-005	2

^IRemove and check continuity and then hand tighten.

^{II}Remove and hand tighten.

9.4 COOLING SYSTEM

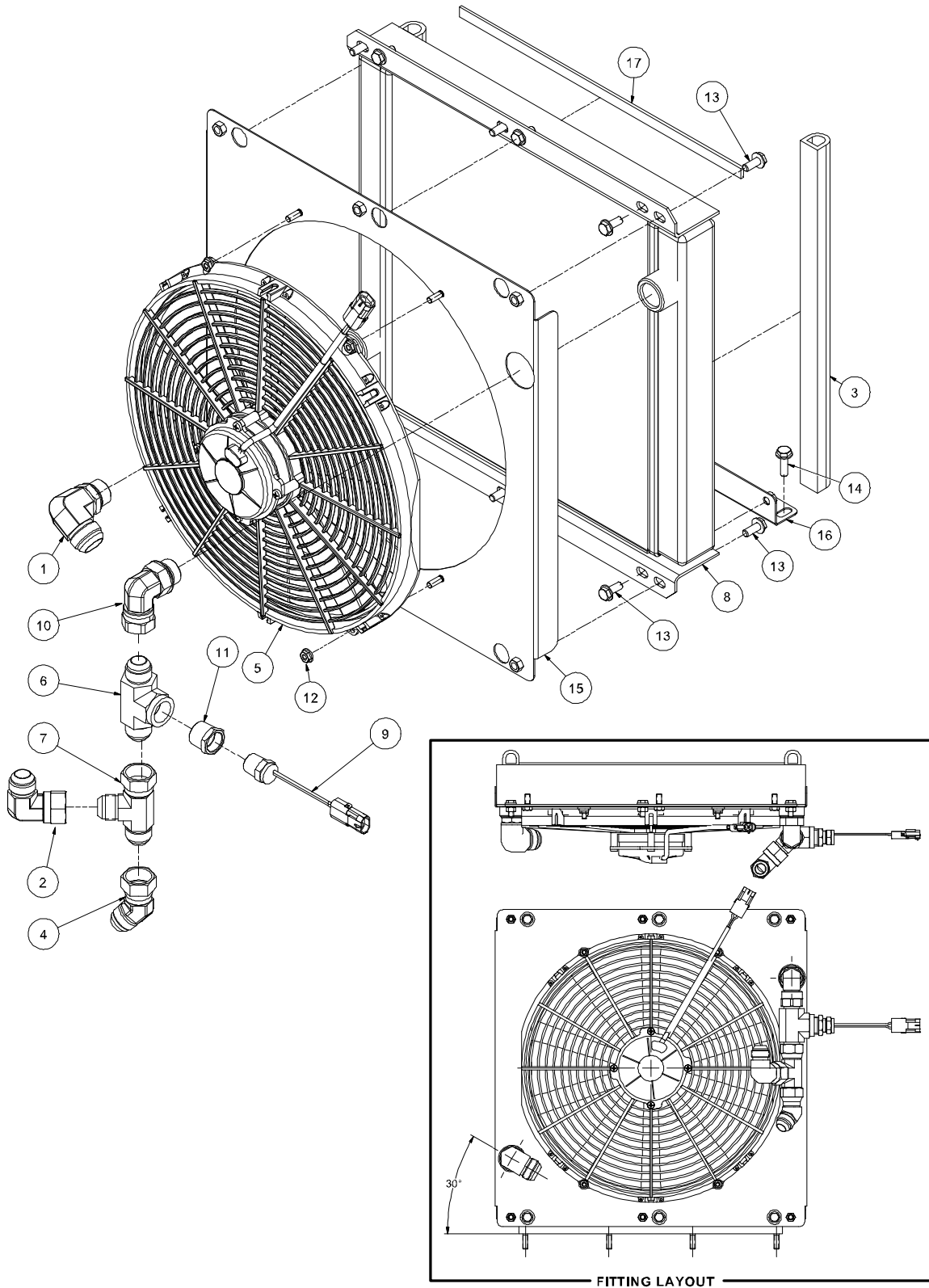

PA6020033ID_r2

9.4 COOLING SYSTEM

ITEM	DESCRIPTION	PART NUMBER	QTY
1	ELBOW, 90 DEG. #16 MJIC x #12 MSAE	260403-117	1
2	ELBOW, 90 DEG. SWIVEL #12 FJIC x #12 MJIC	261842-008	1
3	SEAL, RUBBER "D" TRIM-LOK 1" x 1" x 17" LG	264138	2
4	ELBOW, 45 DEG #12 FJIC SWIVEL x #12 MJIC	265070-006	1
5	FAN AND MOTOR ASSY 16" DIA .PUSHER	266199	1
6	TEE, FEMALE BRANCH #8 MJIC x #8 MJIC x 1/2 FNPT	266581-009	1
7	TEE, RUN SWIVEL 3/4	268769-006	1
8	COOLER, OIL RC40 2.00 CORE SINGLE PASS	269563	1
9	SWITCH , TEMPERATURE (ELECTRIC)	270853	1
10	ELBOW, 90 DEG. #12 FJIC SWIVEL x #12 MSAE	271777-005	1
11	BUSHING, RED STEEL 3/4 x 1/2	807603-020	1
12	NUT, HEX FLANGE 1/4-20	825304-236	4
13	SCREW, SER WASH 5/16-18 x 0.75	829705-075	12
14	SCREW, SER WASH 5/16-18 x 1	829705-100	4
15	SHROUD, COOLER ANA 300H	A1271449	1
16	MOUNT, COOLER LOWER	A1271450	1
17	GASKET, SEAL AND TRIM, 16-1/8" LG.	PR35734	2

9.5 COOLING SYSTEM - COMPRESSOR

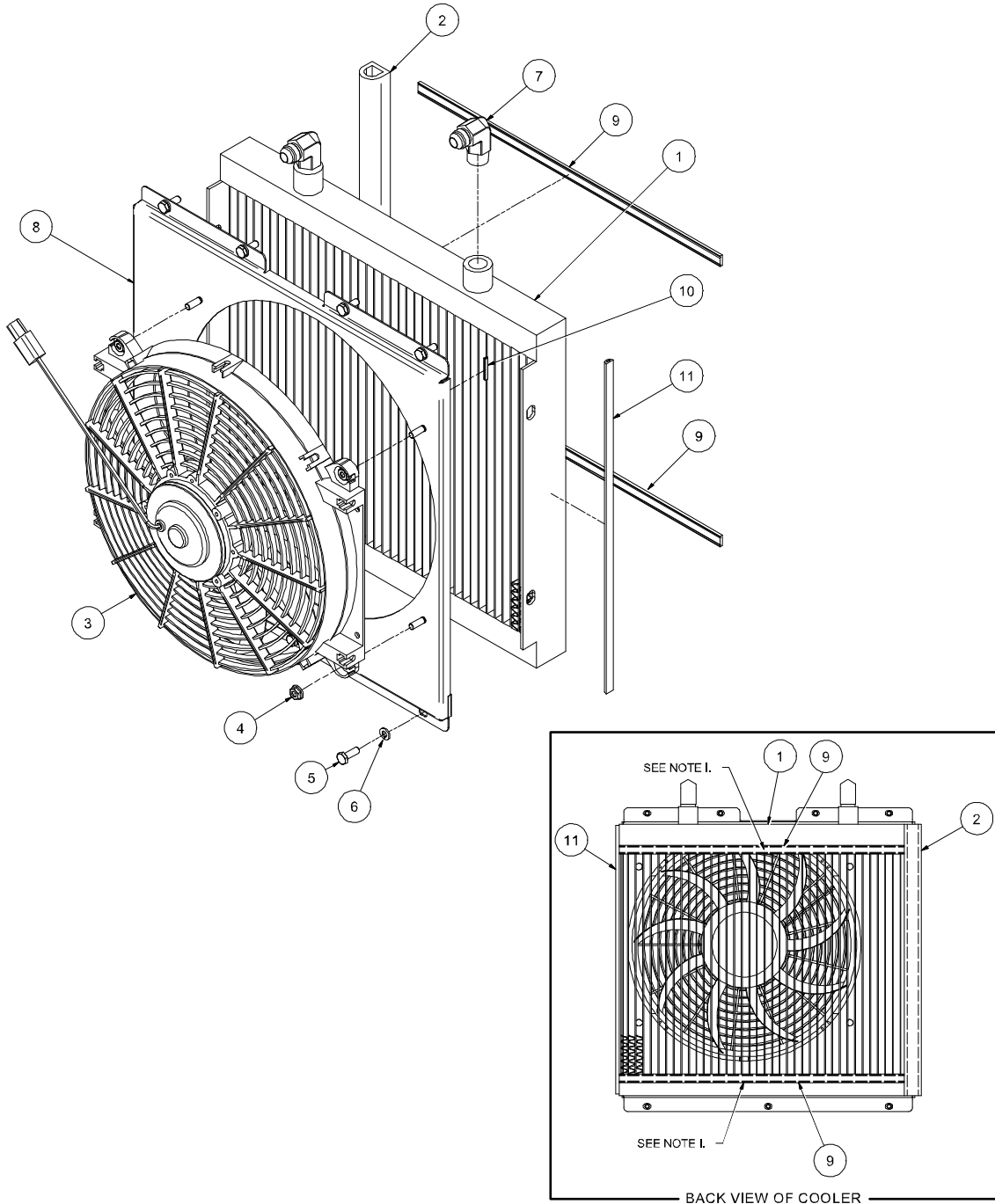

PA6020036ID_r1

9.5 COOLING SYSTEM - COMPRESSOR

ITEM	DESCRIPTION	PART NUMBER	QTY
1	COOLER, OIL NK40	264121	1
2	SEAL, RUBBER "D" TRIM-LOK 1" x 1"	264138	1.3 FT
3	FAN & MOTOR ASSY. 13" PUSH 12V	271446	1
4	NUT, HEX FLANGE 1/4-20	825304-236	4
5	CAPSCREW, HEX GR5 1/4-20 x 0.75	829104-075	7
6	WASHER, LOCK 1/4	838504-062	7
7	ELBOW, 37FL/90M #08 x 1/2	860208-050	2
8	SHROUD, COOLER	A1269742	1
9	GASKET, SEAL AND TRIM, 16-1/2" LG.	PR35734	2
10	TRIM, VINYL COVERED STEEL, BLACK X 1.0 LG.	PR45785	4
11	GASKET, ADHESIVE BACK, D SHAPE	PR81501	1.3 FT

¹Align weather strip with weld seam on cooler.

9.6 FRAME AND CANOPY ASSEMBLY

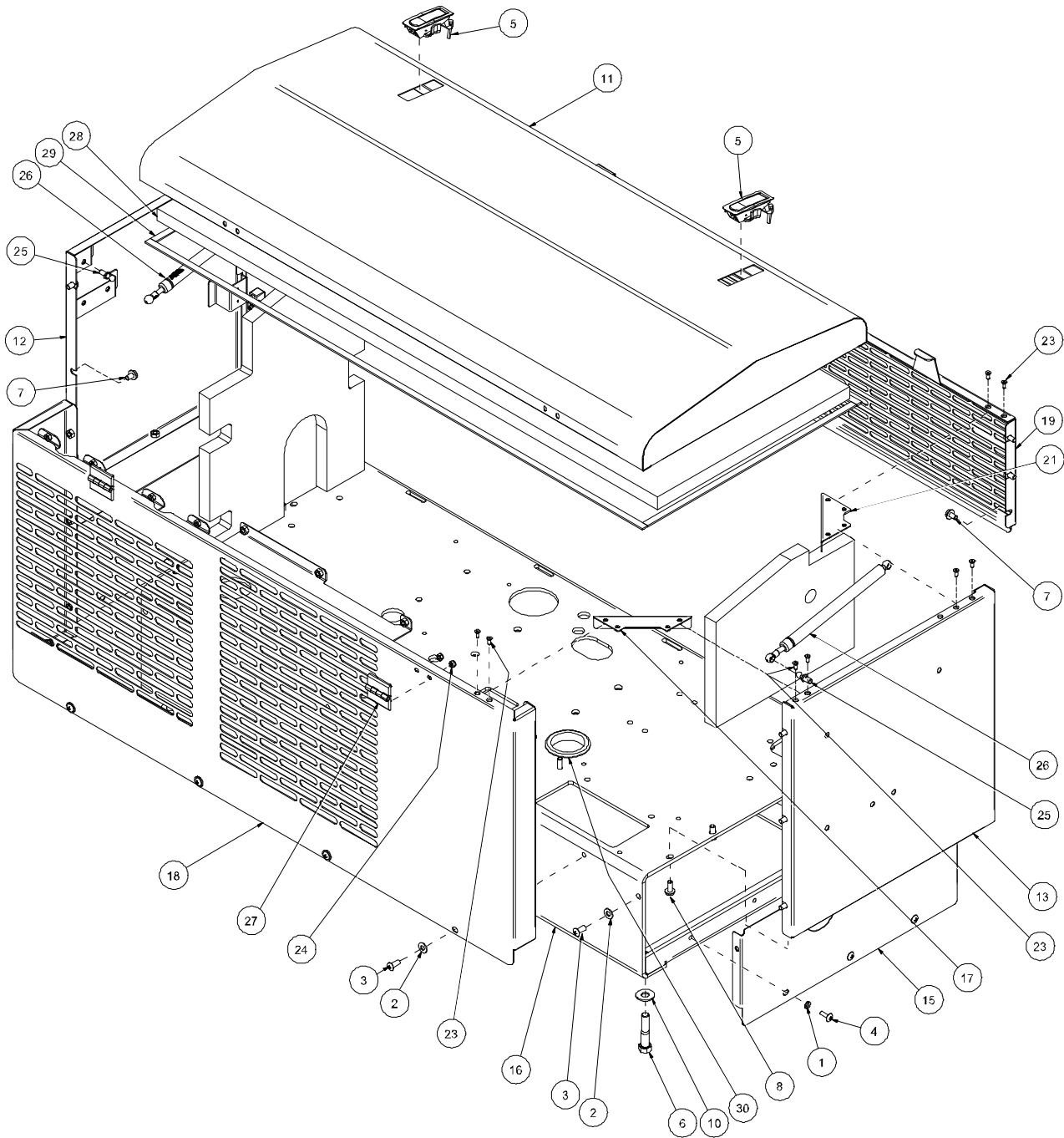

PA6U30031ID_RU

9.6 FRAME AND CANOPY ASSEMBLY

ITEM	DESCRIPTION	PART NUMBER	QTY
1	WASHER, NYLON FLAT 1/4	262704	6
2	WASHER, NYLON 5/16-18	262943	8
3	SCREW, TRUSS HD 5/16-18 x 3/4 SS	262945	8
4	SCREW, TRUSS HD 1/4-20 x 3/4	262953	6
5	LATCH, SENTRY PANEL	267124	4
6	CAPSCREW, HEX GR8 1/2-13 x 2.5	829408-250	4
7	SCREW, SER WASH 5/16-18 x 0.5	829705-050	12
8	SCREW, SER WASH 5/16-18 x 0.75	829705-075	8
9	SCREW, MACHINE #6-32 x 1	831600-100	2
10	WASHER, FLAT 1/2	838208-112	4
11	CANOPY, HOOD	A1269763	1
12	CANOPY, SIDE, LH	A1269765	1
13	CANOPY, SIDE, RH	A1269766	1
14	COVER, BASE	A1269769	1
15	COVER, BASE WITH CUTOUT	A1269980	1
16	PLATFORM	A1270359	1
17	SUPPORT, CROSS BRACE	A1270459	2
18	CANOPY, REAR	A1271301	1
19	CANOPY, FRONT UPPER	A1271302	1
20	CANOPY, FRONT LOWER	A1271383	1
21	SUPPORT, CROSS BRACE LESS FUEL	A1271451	1
22	SWITCH, HOOD SAFETY NO/NC 15A-125V. AC	CO81774	1
23	CAPSCREW, S.H.FLAT #10-24 x 1/2	FA269805	12
24	NUT, LOCK, M6 x 1.0 PITCH	FA55272	9
25	STUD, BALL, .39 DIA. x .55LG.	FA58724	4
26	GAS SPRING, 6 STROKE, 20#	HA72205	2
27	HINGE, 2" x 2", BLACK	HA88014	2
28	KIT, 1" ACOUSTICAL FOAM INSULATION	PR271526	1
29	GASKET, SEAL AND TRIM (16 FT TOTAL)	PR35734	1
30	GROMMET, BLACK RUBBER, 2.25ID	PR74492	1

9.7 INSTRUMENT PANEL (1 OF 2)

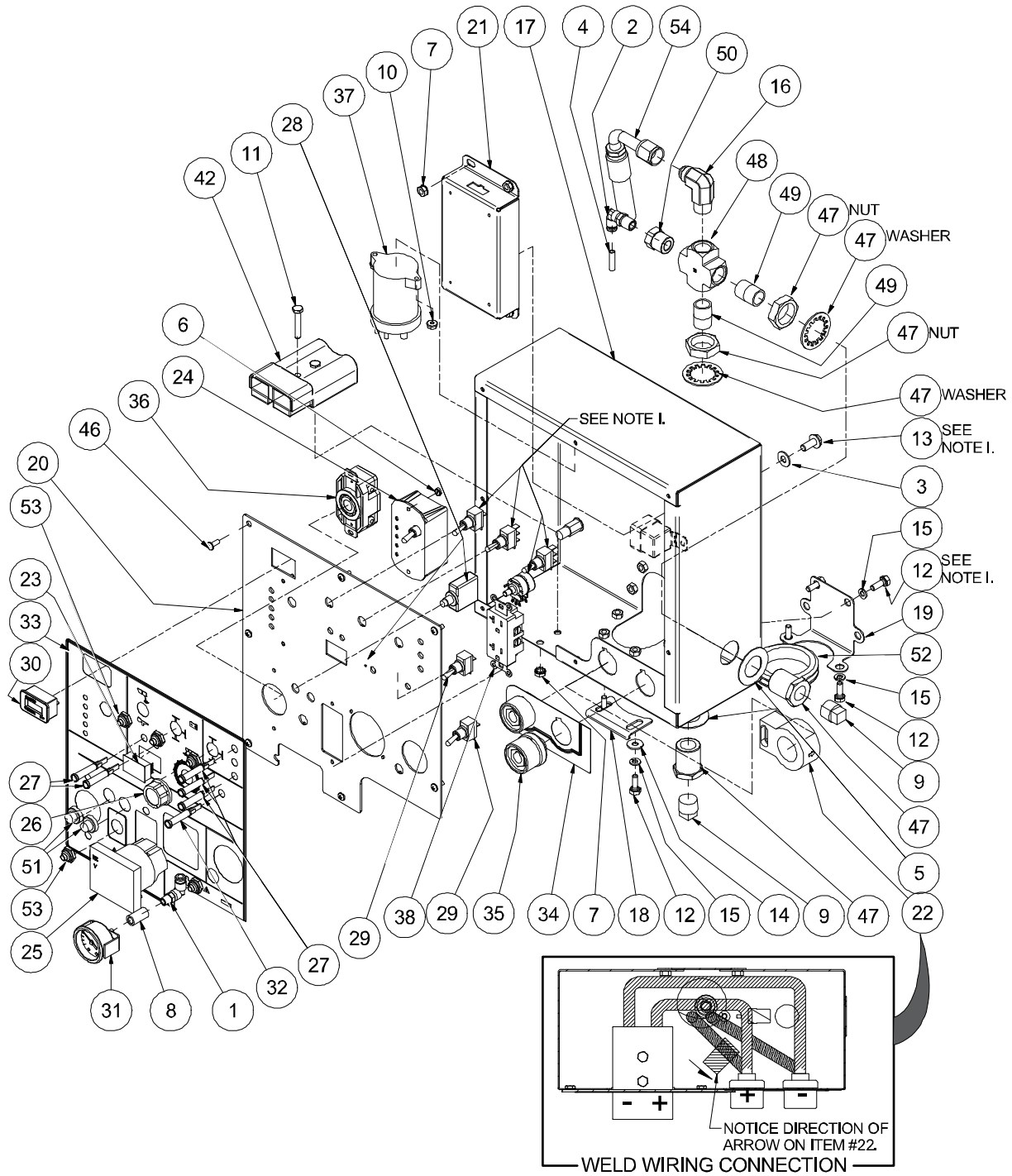

PA6040027ID_r1

9.7 INSTRUMENT PANEL (1 OF 2)

ITEM	DESCRIPTION	PART NUMBER	QTY
1	ELBOW, 1/4T x 1/8P PUSH-ON	261309	1
2	ELBOW, 90 DEG. PUSH ON 1/4T x 1/4P	261310	1
3	WASHER, NYLON 5/16-18	262943	2
4	TUBING, 1/4 DIA., NYLON, 230 PSI X 1.25 FT	264480	1
5	WASHER, FLAT REDUCING 3/4 x 1 ELECT.	267994	2
6	NUT, HEX 6-32 W/ TOOTHWASHER	269202	2
7	NUT, LOCK W/TOOTH LOCKWASHER, 1/4-20	270970	6
8	COUPLING, PIPE 1/8	806230-005	1
9	PLUG, PIPE 1/2	807800-020	2
10	NUT, HEX LOCKING #10-24	825502-083	2
11	CAPSCREW, HEX GR5 1/4-20 X 1 1/2 LG.	829104-150	2
12	CAPSCREW, HEX GR8 1/4-20 X 3/4 LG	829404-075	6
13	SCREW, SER WASH 5/16-18 x 0.75	829705-075	2
14	WASHER, FLAT 1/4	838204-071	2
15	WASHER, LOCK 1/4	838504-062	6
16	ELBOW, 37FL/90M #08 x 1/2	860208-050	1
17	PANEL, CONTROL BACK	A1269489	1
18	CLAMP, CONTROL PANEL CABLE	A1269491	1
19	COVER, CONTROL PANEL CABLES	A1269492	1
20	FACEPLATE, CONTROL PANEL	A1271379	1
21	MODULE, WELD CONTROL SYS ASSY	CO269598	1
22	SENSOR, HALL EFFECT WELD CONTROLS	CO269900	1
23	PANELMETER, VOLTAGE, LED	CO270314	1
24	MODULE, SYSTEM SHUTDOWN W/LIGHT	CO271474	1
25	METER, FREQUENCY AC DIGITAL	CO271552	1
26	KNOB, PLASTIC, 1.3 DIA., 1/4 SHAFT	CO59489	1
27	LAMP, INDICATOR, LED, GREEN	CO59966	5
28	CIRCUIT BREAKER, 20 AMP	CO62617	2
29	SWITCH, TOGGLE, SPST, ON/OFF	CO78077	2
30	TACHOMETER, HOUR, 12V SINGLE	CO79106	1
31	GAUGE, AIR, DRY, 0-200 PSI	CO89649	1

Continued on page 131

9.7 INSTRUMENT PANEL (2 OF 2)

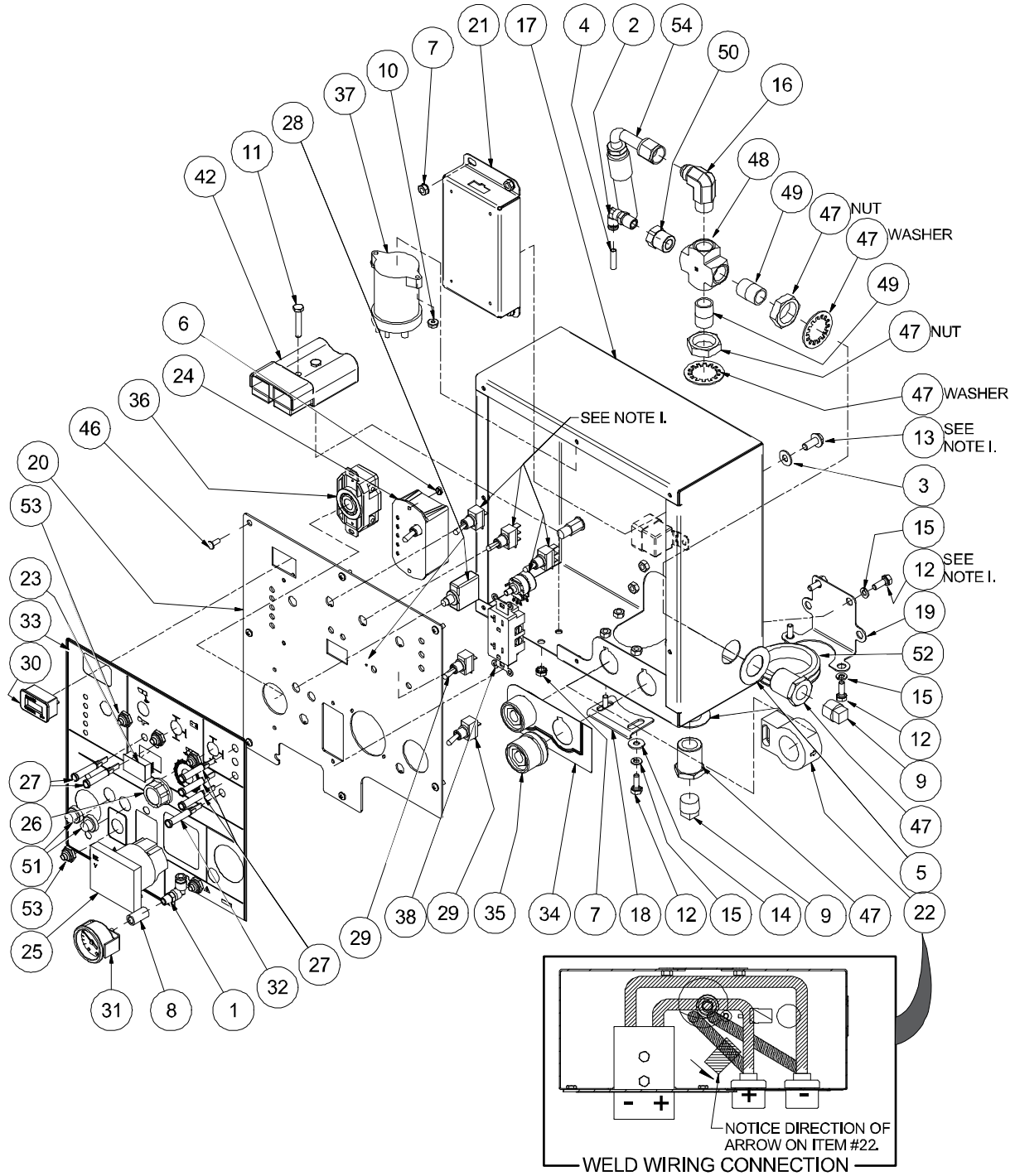

PA6040027ID_r1

9.7 INSTRUMENT PANEL (2 OF 2)

ITEM	DESCRIPTION	PART NUMBER	QTY
32	LAMP, INDICATOR, LED, RED	CO89659	1
33	DECAL, FACEPLATE	DL271380	1
34	DECAL, CONTROL PANEL, WELDER	DL271380-002	1
35	RECEPTACLE, PANEL 350 AMP	EL269932	2
36	RECEPTACLE, 240V/30A TURNLOC	EL270148	1
37	RELAY, 500 AMP 12V COIL NO	EL270483	1
38	RECEPTACLE, DUPLEX, 20AMP-125V	EL55121	1
39	HARNESS, WIRE INST PNL LIGHTS	EP269871	1
40	HARNESS, WIRE INST PNL SWITCH	EP269872	1
41	HARNESS, WELD CABLE MACH	EP270170	1
42	HARNESS, WELD CABLE JUMPER	EP270171	1
43	HARNESS, A/C PANEL TO MACHINE	EP270230	1
44	HARNESS, WIRE INST. PNL DISPLAY	EP270315	1
45	HARNESS, WIRE INST PNL	EP271381	1
46	SCREW, PHILLIPS PAN HEAD #10-32 x 1/2" LG. SS	FA33542	7
47	PIPE BRASS, BULKHEAD 1/2 NPT	FI23542	2
48	PIPE BRASS, CROSS, 1/2 NPT.	FI25405	1
49	NIPPLE, PIPE XS CLOSE 1/2, BRASS	FI34220	2
50	BUSHING, PIPE BRASS 1/4 x 1/2	FI75068	1
51	BOOT, CIRCUIT BREAKER 3/8	PR270548	2
52	GROMMET, BLACK RUBBER, 2.25ID	PR74492	1
53	SWITCH BOOT, TOGGLE, WEATHER PROOF	PR77230	5
54	HOSE, AIR TANK TO PANEL	TU271455-002	1

¹Toggle switches and potentiometer are included with harness #EP269872; wiring inst. pnl. switches.

9.8 GENERATOR AND PARTS

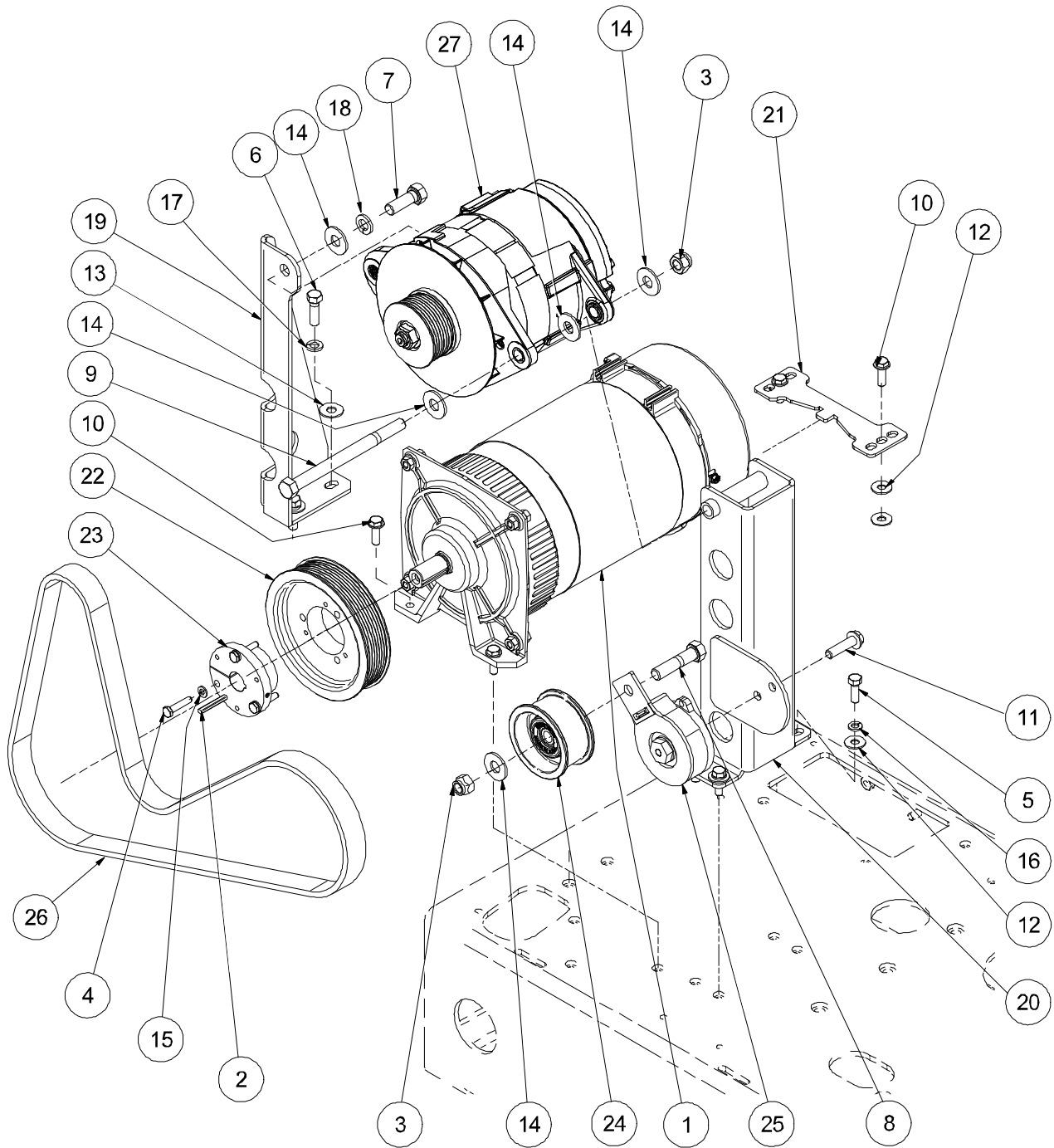

PA6050012ID_r1

9.8 GENERATOR AND PARTS

ITEM	DESCRIPTION	PART NUMBER	QTY
1	GENERATOR, AC, 6.8KW	269530	1
2	KEY, SQUARE 3/16 x 3/16 x 1.5	821103-150	1
3	NUT, HEX LOCKING 1/2-13	825508-262	2
4	CAPSCREW, HEX GR5 1/4-20 x 1 1/4	829104-125	3
5	CAPSCREW, HEX GR8 5/16-18 x 1.0 LG.	829405-100	4
6	CAPSCREW, HEX GR8 3/8-16 x 1 1/4	829406-125	2
7	CAPSCREW, HEX GR8 1/2-1 x 11/2	829408-150	1
8	CAPSCREW, HEX GR8 1/2-13 x 2.25	829408-225	1
9	CAPSCREW, HEX GR8 1/2-13 x 6.5	829408-650	1
10	SCREW, SER WASH 5/16-18 x 1	829705-100	4
11	SCREW, SER WASH 3/8-16 x 1.5	829706-150	1
12	WASHER, FLAT 5/16	838205-071	8
13	WASHER, FLAT 3/8	838206-071	2
14	WASHER, FLAT 1/2	838208-112	5
15	WASHER, LOCK 1/4	838504-062	3
16	WASHER, LOCK 5/16	838505-078	4
17	WASHER, LOCK 3/8	838506-094	2
18	WASHER, LOCK 1/2	838508-125	1
19	BRACKET, WELD GENERATOR	A1269734	1
20	BRACKET, WELD GENERATOR SUPPORT	A1270388	1
21	MOUNT, REAR GENERATOR	A15865P	1
22	SHEAVE, SERPENTINE, 8 GROOVE	A15891Z	1
23	BUSHING, SDS, QD, 7/8 DIA.	DR41395Z	1
24	IDLER, 1.375 WIDTH, 3 3/8 DIA	DR46584	1
25	TENSIONER, ROTARY, LARGE, 42#	DR61391	1
26	BELT, SERPENTINE, 8 RIB x 62.0", BLACK RUBBER	DR62184	1
27	WELDER, GENERATOR 300 AMP	GE270045	1

9.9 MOTOR ASSEMBLY

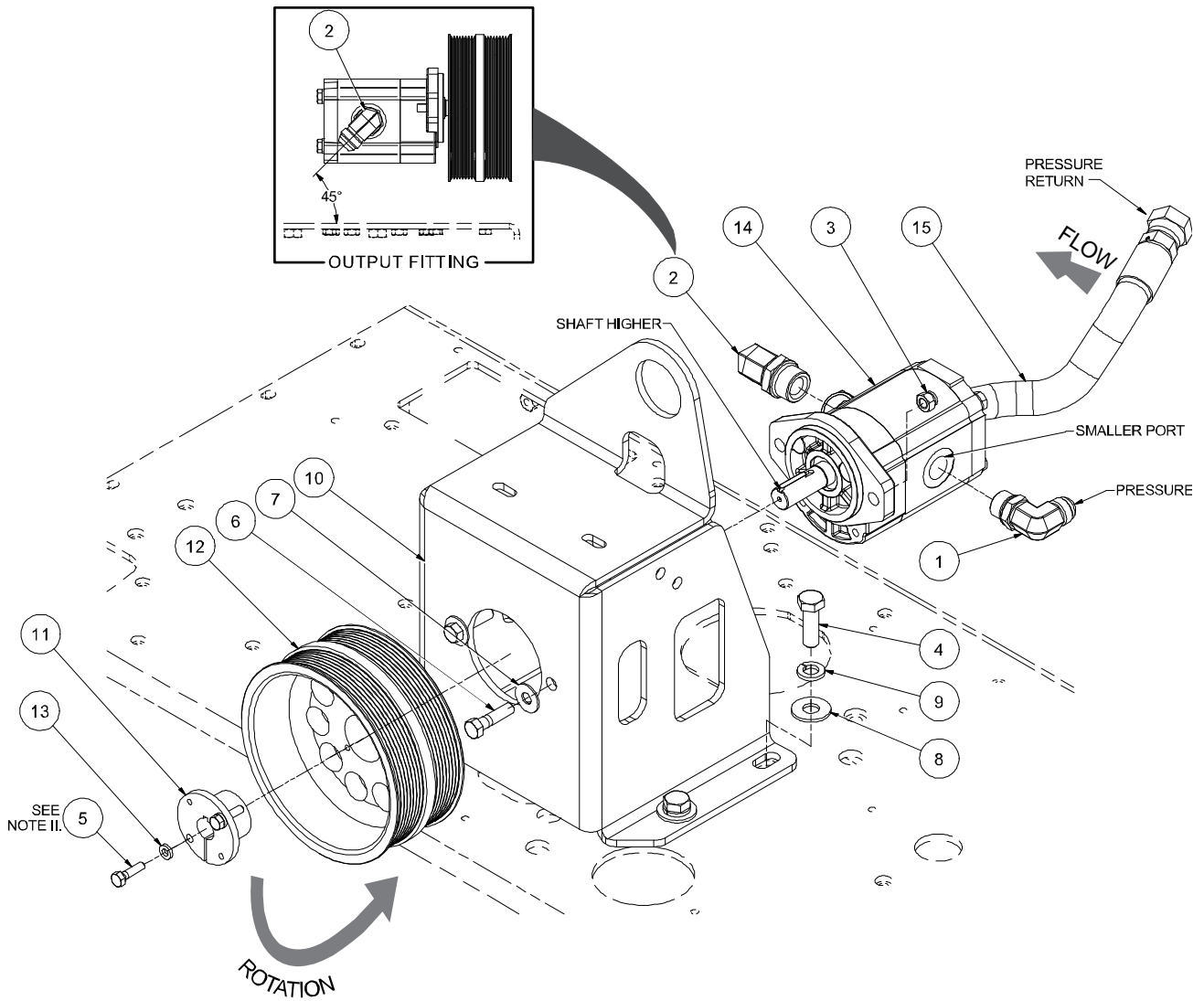

PA6100027ID_r2

9.9 MOTOR ASSEMBLY

ITEM	DESCRIPTION	PART NUMBER	QTY
1	ELBOW, 90 DEG #10 MJIC x #10 MSAE	260403-106	1
2	ELBOW, 90 DEG #12 MJIC x #12 MSAE	260403-107	1
3	NUT, HEX LOCKING 3/8-16	825506-198	2
4	CAPSCREW, HEX GR5 1/2-13 x 1.5	829108-150	4
5	CAPSCREW, HEX GR8 1/4-20 x 1	829404-100	2
6	CAPSCREW, HEX GR8 3/8-16 x 1 1/2	829406-150	2
7	WASHER, FLAT 3/8	838206-071	2
8	WASHER, FLAT 1/2	838208-112	4
9	WASHER, LOCK 1/2	838508-125	4
10	MOUNT, MOTOR	A1271414	1
11	BUSHING, QD STYLE QT 3/4" BORE PLATED	DR268487Z	1
12	SHEAVE, COMP / GEN	DR271303	1
13	WASHER, 1/4ID x 1/2OD, 2 PIECE LOCKING	FA67466	2
14	MTR, HYDRAULIC 2-BOLT W/OUTBOARD BRG	HY271406	1
15	HOSE, MOTOR RETURN TO COOLER	TU271455-012	1

^INotice port sizes and motor orientation. Motor must be installed correctly for proper rotation (counter-clockwise).

^{II}Torque to 120 in-lbs

9.10 AIR STORAGE TANK

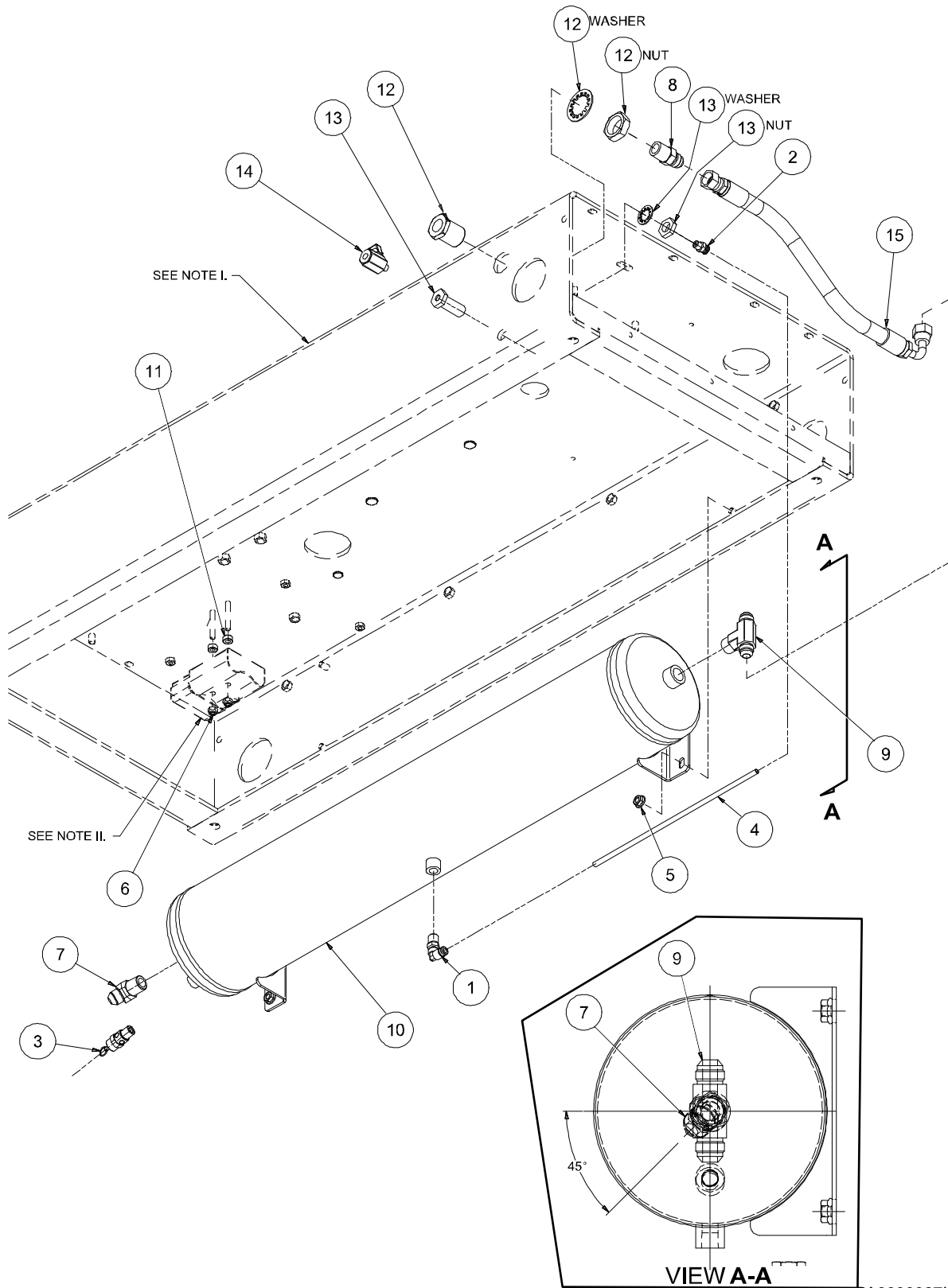

PA6000027ID_r4

9.10 AIR STORAGE TANK

ITEM	DESCRIPTION	PART NUMBER	QTY
1	ELBOW, 90 DEG. PUSH ON 1/4T x 1/4P	261310	1
2	CONNECTOR, 1/8P x 1/4T PUSH ON	261316	1
3	VALVE, RELIEF 200 PSI 1/4 NPT MALE	264232	1
4	TUBING, 1/4 DIA., NYLON, 230 PSI x 3.5 FT	264480	1
5	NUT, HEX FLANGE 5/16-18	825305-283	4
6	NUT, HEX LOCKING 1/4-20	825504-145	2
7	ELBOW, 45 DEG. 1/2 MPT x #8 MJIC	860008-050	1
8	CONNECTOR, 37FL/MPT #08 x 1/2	860108-050	1
9	TEE, 37FL/M BR #8 x 1/2	861708-050	1
10	TANK, AIR ACCUMULATOR 4 GAL	A1269633	1
11	SPACER, NYLON, 1/2 OD x 1/4 ID	FA29036	2
12	PIPE BRASS, BULKHEAD 1/2 NPT	FI23542	1
13	PIPE BRASS, BULKHEAD 1/8 NPT	FI54337	1
14	VALVE, BALL MINI, 1/8NPT M/F,	FI95272	1
15	HOSE, AIR TANK TO S.P.	TU271455-003	1

^IRef. A1269476; platform ANA 300

^{II}Ref. EL52049

^{III}Install electrical connector prior to installing air tank.

9.11 ASSEMBLY FLOW CONTROL (1 OF 2)

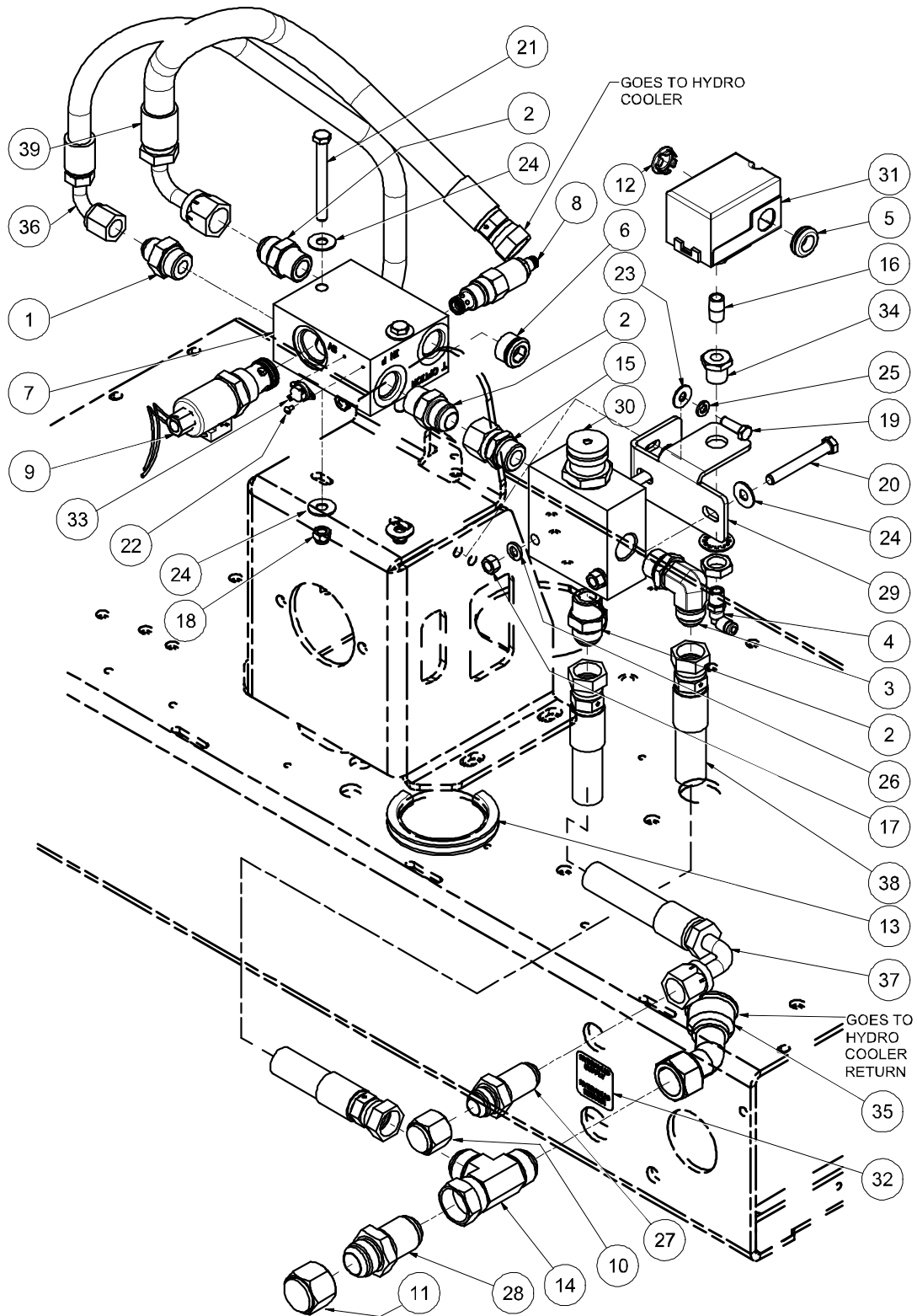

PA6120097ID_r4

9.11 ASSEMBLY FLOW CONTROL (1 OF 2)

ITEM	DESCRIPTION	PART NUMBER	QTY
1	CONNECTOR, O-RING 7/8 x 1-1/16JIC	260387-110	1
2	CONNECTOR, O-RING 3/4 x 3/4 JIC	260387-112	3
3	ELBOW, 90 DEG. #12 MJIC x #12 MSAE	260403-107	1
4	ELBOW, 90 DEG. PUSH ON 1/4T x 1/4P	261310	1
5	GROMMET, RUBBER 5/8 x 7/8 x 1/8	262905	1
6 *	PLUG, MALE O-RING 3/4"	263740	1
7	MANIFOLD, HYDRAULIC SOLENOID	263878	1
8	VALVE, PRESSURE RELIEF	263878-003	1
9	VALVE, SOLENOID WITH 12V. COIL	263878-004	1
10	CAP, FEMALE JIC 1 1/16-12 #12	264322-005	1
11	CAP, FEMALE JIC 1 5/16-12 #16	264322-006	1
12	SEAL, KNOCKOUT 1/2"	264443	1
13	TRIM-LOK, 1/4 GROOVE x 7.5" LONG	268080	1
14	TEE, RUN SWIVEL #16	268769-008	1
15	ADAPTER, 3/4 FJIC SWIVEL X #12 MSAE	270440-013	1
16	NIPPLE, PIPE XS CLOSE 1/4	822204-000	1
17	NUT, HEX 3/8-16	825206-337	2
18	NUT, HEX LOCKING 3/8-16	825506-198	2
19	CAPSCREW, HEX GR5 5/16-18 x 1	829105-100	2
20	CAPSCREW, HEX GR5 3/8-16 x 3	829106-300	2
21	CAPSCREW, HEX GR5 3/8-16 x 3.5	829106-350	2
22	SCREW, MACH #6-32 x 1/4"	831600-025	2
23	WASHER, FLAT 5/16	838205-071	2
24	WASHER, FLAT 3/8	838206-071	6
25	WASHER, LOCK 5/16	838505-078	2
26	WASHER, LOCK 3/8	838506-094	2
27	BULKHEAD, MJIC x MJIC #12	862112-075	1
28	BULKHEAD, MJIC x MJIC #16	862116-100	1
29	BRACKET, FLOW CONTROL	A1271453	1
30	CONTROL, FLOW	CO271444	1
31	SWITCH, PRESSURE ADJUSTABLE 50-175 PSI	CO271659	1

Continued on page 141

9.11 ASSEMBLY FLOW CONTROL (2 OF 2)

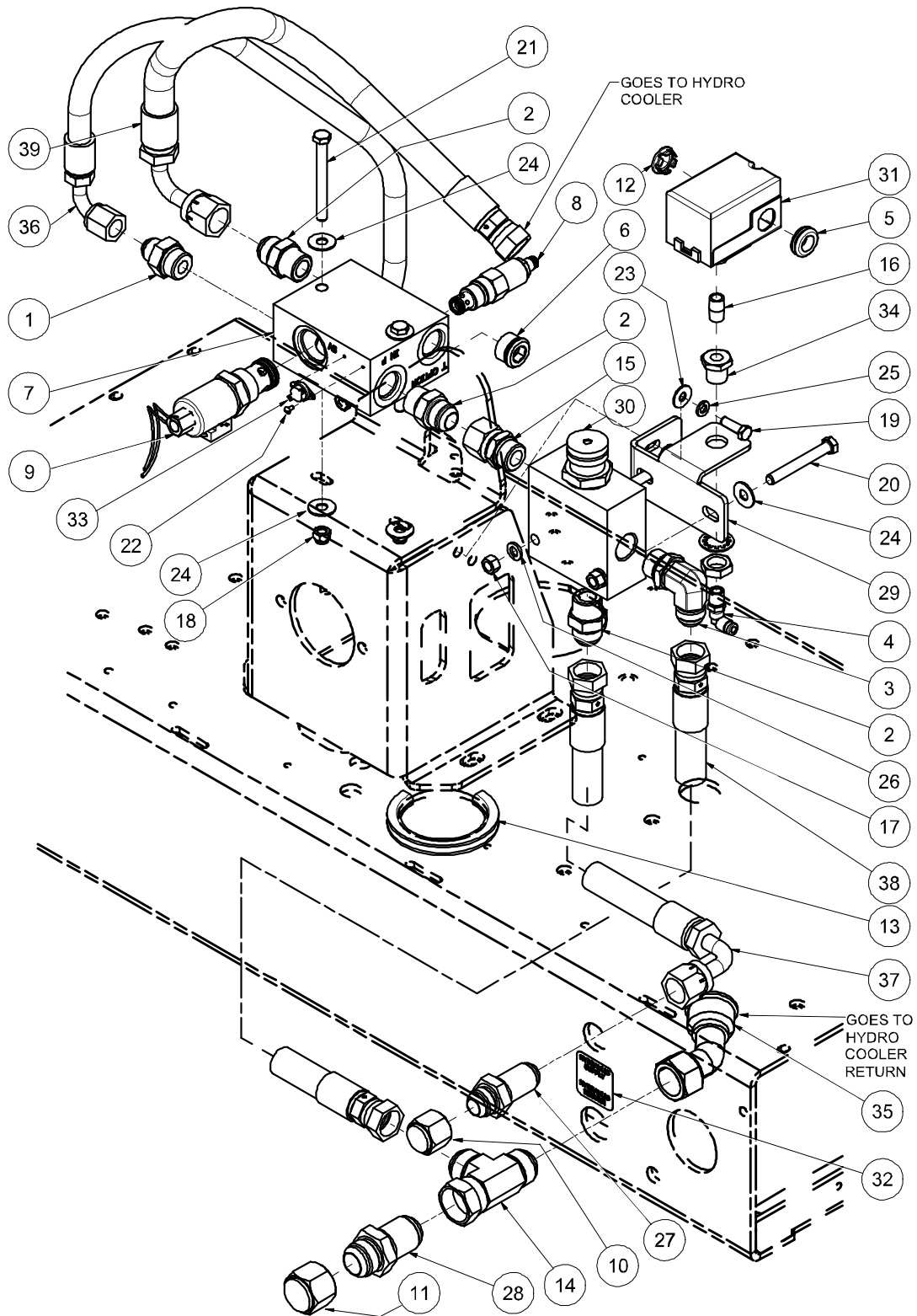

PA612009/ID_r4

9.11 ASSEMBLY FLOW CONTROL (2 OF 2)

ITEM	DESCRIPTION	PART NUMBER	QTY
32	DECAL, HYDRAULIC LABEL	DL271919	1
33	THERMOSTAT, DISC CLOSE ON RISE 100 F	EL270040	1
34	PIPE BRASS, BULKHEAD 1/4 NPT	FI45068	1
35	HOSE, COOLER TO RETURN	TU271455-007	1
36	HOSE, HYDRAULIC BLOCK TO MOTOR	TU271455-008	1
37	HOSE, PRESSURE IN	TU271455-009	1
38	HOSE, EXCESS FLOW TO RETURN	TU271455-010	1
39	HOSE, SOLENOID TO COOLER	TU271455-011	1

[†]Items marked with "*" are included with P/N 363878.

9.12 DECAL LOCATIONS (1 OF 3)

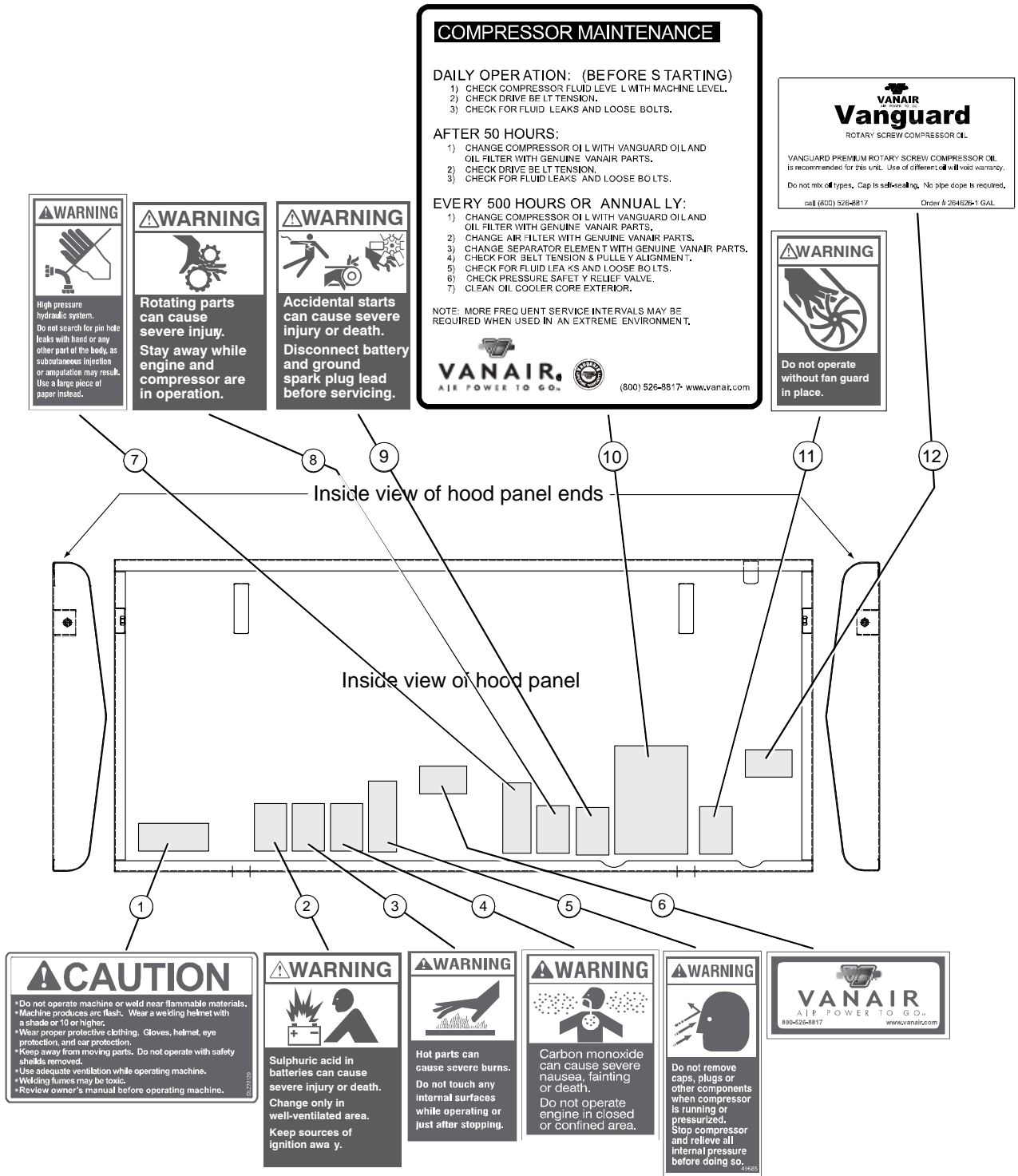

9.12 DECAL LOCATIONS (1 OF 3)

ITEM	DESCRIPTION	PART NUMBER	QTY
1	DECAL, CAUTION	DL270120	1
2	DECAL, SULPHURIC ACID	264375	1
3	DECAL, HOT PARTS	264372	1
4	DECAL, CARBON MONOXIDE	264376	1
5	DECAL, CAP REMOVAL	049685	1
6	DECAL, VANAIR INFORMATION	ɿ	1
7	DECAL, HIGH PRESSURE HYDRAULIC SYSTEM	264380	1
8	DECAL, ROTATING PARTS	264374	1
9	DECAL, ACCIDENTAL STARTS	264373	1
10	DECAL, COMPRESSOR MAINTENANCE	ɿ	1
11	DECAL, FAN GUARD	264383	1
12	DECAL, VANGUARD	63533-2	1

^ɿThis decal is included with decal sheet no. 263452

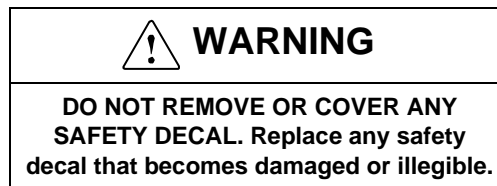

9.12 DECAL LOCATIONS (2 OF 3)

FRONT VIEW

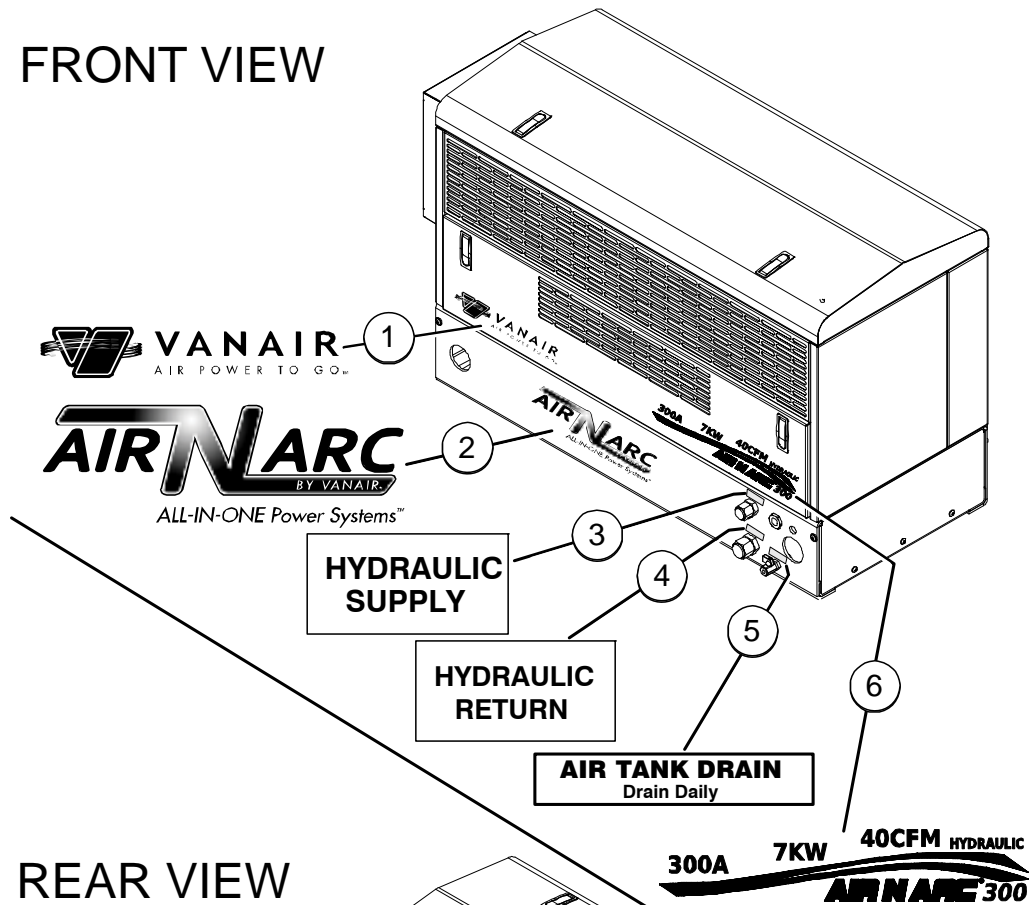

REAR VIEW

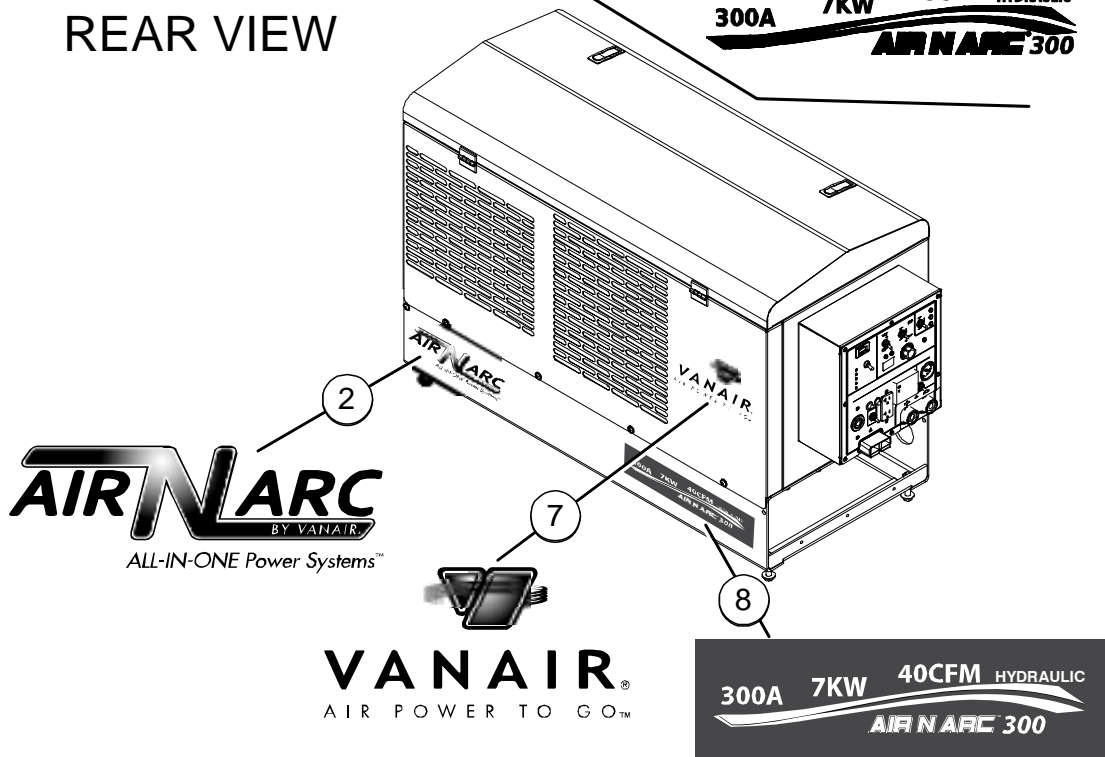

9.12 DECAL LOCATIONS (2 OF 3)

ITEM	DESCRIPTION	PART NUMBER	QTY
1	DECAL, ANA 300 VANAIR LOGO 16.5"	DL269707	1
2	DECAL, ANA BY VANAIR, WHT.	269706	2
3	DECAL, HYDRAULIC SUPPLY	ɿ	1
4	DECAL, HYDRAULIC RETURN	ɿ	1
5	DECAL, AIR TANK DRAIN	DL269676	1
6	DECAL, PERF, BLACK	DL271389	1
7	DECAL, VANAIR	DL269707	1
8	DECAL, ANA HYDRAULIC	DL271388	1

^ɿThis decal is included with decal sheet no. 263452.

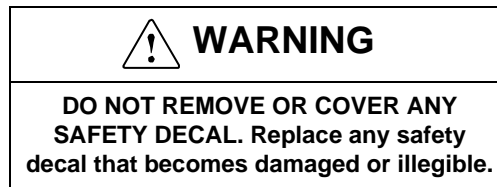

9.12 DECAL LOCATIONS (3 OF 3)

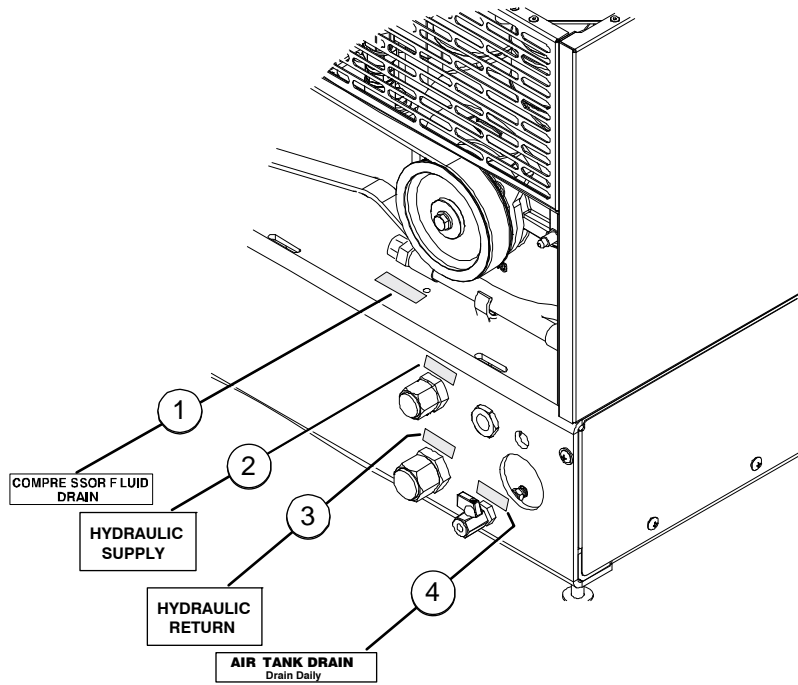

9.12 DECAL LOCATIONS (3 OF 3)

ITEM	DESCRIPTION	PART NUMBER	QTY
1	DECAL, COMPRESSOR FLUID DRAIN		1
2	DECAL, HYDRAULIC SUPPLY	I	1
3	DECAL, HYDRAULIC RETURN	I	1
4	DECAL, AIR TANK DRAIN		1

^IThis decal is included with decal sheet no. 263452.



WARNING

DO NOT REMOVE OR COVER ANY SAFETY DECAL. Replace any safety decal that becomes damaged or illegible.

APPENDIX A: ADDITIONAL INFORMATION

A.1 ELECTRIC MOTOR CHART - STARTING WATTS^I

NOTE

For pumps, air compressors, air conditioners, inverters add at least 25% to starting current.

HORSEPOWER	RUNNING WATTS	UNIVERSAL MOTOR (sm. appliance)	INDUCTION MOTOR	CAPACITOR MOTOR	SPLIT PHASE MOTOR
1/6	275	400	600	850	1200
1/4	400	500	850	1050	1700
1/3	450	600	950	1350	1950
1/2	600	750	1300	1800	2600
3/4	850	1000	1900	2600	X
1	1000	1250	2300	3000	X
1 1/2	1600	1750	3200	4200	X
2	2000	2350	3900	5100	X
3	3000	X	5200	6800	X
5	4800	X	7500	9800	X

^IApproximate current requirements.

A.2 EXTENSION CORD CHART

CONTINUOUS LOAD (use either Amps or Watts below)			MINIMUM GAUGE (AWG)		
AMPS	@ 120 volts	@240 volts	0-50 feet	50-100 feet	100-150 f
2	240	480	22	20	18
3	360	720	22	18	16
4	480	960	20	16	16
5	600	1200	18	16	14
6	720	1440	18	16	14
8	960	1920	16	14	12
10	1200	2400	16	12	12
12	1440	2880	16	12	10
14	1680	3660	14	12	10
16	1920	3840	14	10	10
18	2160	4320	14	10	8
20	2400	4800	12	10	8
22	2640	5280	12	10	8
25	3000	6000	12	10	6
30	3600	7200	10	8	6
35	4200	8400	10	8	4
40	4800	9600	8	6	2
50	6000	12000	6	4	2
60	7200	14400	4	2	

A.3 WATTAGE REQUIREMENTS FOR COMMON RECEPTACLE UNITS

COMMON RECEPTACLE UNIT		WATTAGE	
		STARTING	RUNNING
Battery charger, 10 amps		-	200
Drill	- 1/4"	400	300
	- 3/8"	650	475
	- 1/2"	900	750
	- 1"	1250	1000
Welder 100 amps DC		-	3600
Floodlight		--	1000
Grain cleaner, 1/4 HP		1000	650
Grain elevator, 3/4 HP		3000	1400
Grinders (by motor size)			
Heater radiant portable		--	1300
Heater portable liquid fuel	- 50,000 btu	675	225
	- 100,000 btu	1260	420
	- 150,000 btu	1875	625
Impact wrench	- 1/2"	750	600
	- 3/4"	900	750
	- 1"	1400	1200
Milk cooler		1800	1100
Mixer, 3 ½ cubic feet		2300	1000
Motors			
Belt sander		2600	1200
Disc sander		2600	1200
Orbital sander		2600	1200
Chain saw			
6" circular saw		2200	950
7 ¼" circular saw		2600	1200
8 ½" circular saw		3000	1500
10" circular saw		3900	2000
Sump pump		1300	400
Water pump submersible	- 3000 gph	1750	500
	- 5000 gph	2500	650
	- 10000 gph	3750	1000
	- 15000 gph	5000	1500
Water pump non-submersible	- 3000 gph	2250	600
	- 5000 gph	2850	750
	- 10000 gph	4100	1100
	- 15000 gph	5250	1600

A.4 AIR TOOL AIR CONSUMPTION CHART	
TOOL	AIR REQUIRED CFM @ 90 PSI
Dual Action (DA) Sanders	4-6 CFM
5" High Speed Sanders	4-6 CFM
Jitterbug Sanders	4 CFM
Straight Line Sanders	4 CFM
Air Belt Sanders	5.5 CFM
Air Belt Sanders	4 CFM
Gasket Scrapers	6 CFM
Air Punch and Flange Tool	4 CFM
3/8" Drill	4 CFM
1/2 " Drill	4 CFM
Screw Driver	2.5 CFM
Impact Screw Driver	4 CFM
Speed Saw	5-6 CFM
Body Saw	8 CFM
Jig Saw	6 CFM
16 Gauge Nibbler	4 CFM
Cut Off Tool	4 CFM
150 mm Air Hammer	4 CFM
190 mm Air Hammer	4.2 CFM
High Speed Grinder	8 CFM
Mini Air Grinder	3 CFM
Mini Angle Head Grinder	3 CFM
1/4" Angle Head Grinder	8 CFM
Tire Buffer	4 CFM
1/4" Ratchet Wrench	3 CFM
3/8" Ratchet Wrench	4 CFM
3/8" Butterfly Impact Wrench	3 CFM
1/2" Impact Wrench	4 CFM
1/2" Heavy Duty Impact Wrench	5.5 CFM
3/4" Impact Wrench	7.5 CFM
3/4" Impact Wrench with 6" anvil	7.5 CFM
30 lbs Pavement Breaker	37 CFM
<i>Continued on next page</i>	

A.4 AIR TOOL AIR CONSUMPTION CHART (CONTINUED)

TOOL	AIR REQUIRED CFM @ 90 PSI
60 lb Pavement Breaker	48 CFM
90 lb Pavement Breaker	68-85 CFM
4" Piercing Tool	60 CFM
60 lb 1650 BPM Rock Drill	95 CFM
50 lb 1800 BPM Rock Drill	123 CFM
40 lb 1800 BPM Rock Drill	82 CFM
30 lb 2300 BPM Rock Drill	55 CFM
Chipping Hammers	26-33 CFM

A.5 AIR N ARC 300 SERIES ALL-IN-ONE POWER SYSTEM AVAILABLE OPTIONS LIST

KEY NO.	OPTION ITEM	DESCRIPTION	PART ORDER NUMBER	QTY
1	COMPRESSOR UNLOAD SOLENOID HEATER BLANKET	This heater component is integrated with the electronic fan system so that anytime that compressor switch is on, the blanket is on if the fan is not running. For cold conditions: <ul style="list-style-type: none"> Let the machine warm up with all switches off After the machine has warmed up the compressor can be turned on. 	265870	1
2	BATTERY BOOST CABLES	These cables are 25 feet in length, with quick-connect ends	MA269938	1 set
3	AIR TANK AUTO DRAIN KIT	Automatically drains moisture from the air reservoir	MA66434	1
4	30 GALLON REMOTE AIR TANK ASSEMBLY	This remote-mounted air option allows for an additional capacity for air storage, in addition to the standard four gallon air tank on the machine.	OA49645	1
5	DUAL 14 GALLON (28 GALLON TOTAL) AIR TANK ASSEMBLY	This remote-mounted air option allows for an additional capacity for air storage, in addition to the standard four gallon air tank on the machine.	032708	1
6	SINGLE 14 GALLON AIR TANK ASSEMBLY	This remote-mounted air option allows for an additional capacity for air storage, in addition to the standard four gallon air tank on the machine.	032707	1
7	EXTENSION SEGMENT FOR WELD CABLE	50 feet in length, 1/0 cable with connectors	MA269942	1

Continued on next page

***A.5 AIR N ARC 300 SERIES ALL-IN-ONE POWER SYSTEM AVAILABLE OPTIONS LIST
(CONTINUED)***

KEY NO.	OPTION ITEM	DESCRIPTION	PART ORDER NUMBER	QTY
8	WELD HELMET	2 x 4 auto-darkening lens, solid color (blue)	MA269903	1
9	WELD HELMET LENSE	Replacement lense for welding shield	MA270500	
10	WELD LEAD	25 feet in length, 1/0 cable with electrode holder and connector - 330 amp	MA269814-25	1
11	WELD LEAD	50 feet in length, 1/0 cable with electrode holder and connector - 330 amp	MA269814-50	1
12	WELD LEAD	25 feet in length, 1/0 cable with ground clamp, and connector - 330 amp	MA269815-25	1
13	WELD LEAD	50 feet in length, 1/0 cable with ground clamp, and connector - 330 amp	MA269815-50	1
14	WELDING ROD	LaGrange 100 KSI 1/8" blue	MA98018	per pound
15	WELDING ROD	LaGrange 100 KSI 3/32" blue	MA44890	per pound
16	WELDING ROD	LaGrange 100 KSI 5/32" blue	MA99727	per pound
17	ISOLATOR (BOLT DOWN)	Used to dampen vibration transferred from direct mounting of package. One per mounting bolt (x 4) needed.	PR93969	4
18	AIR GOUGE TORCH	Torch, air gouge	MA269933	1
19	CARBON ARC ELECTRODES	Cabons, pointed arc gouging 3/16" x 12"	MA269935	50 / box

A.6 HOSE INSTALLATION GUIDE

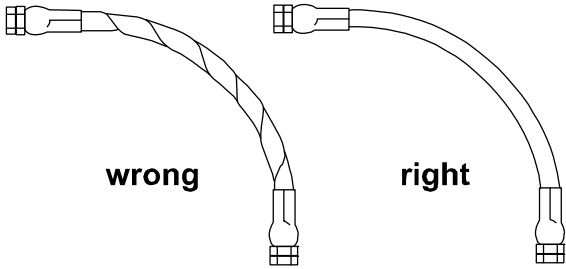
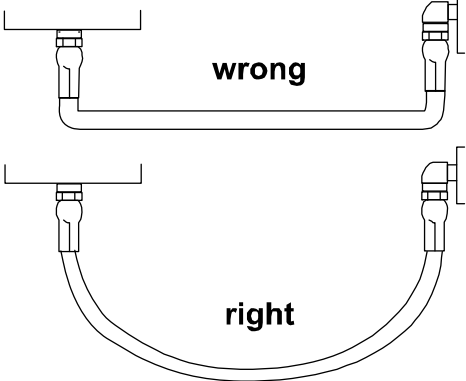
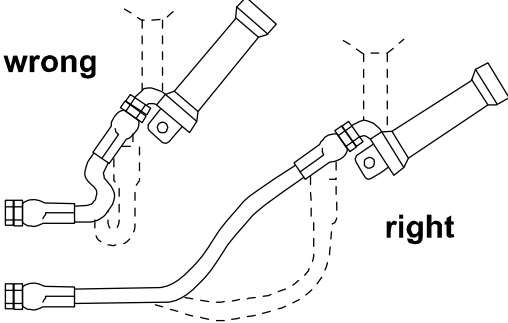
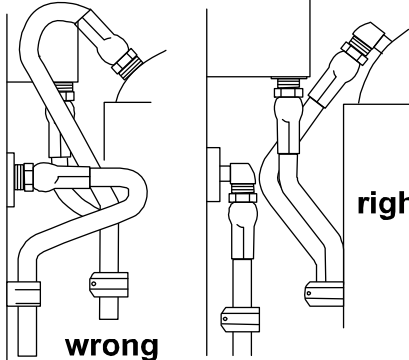
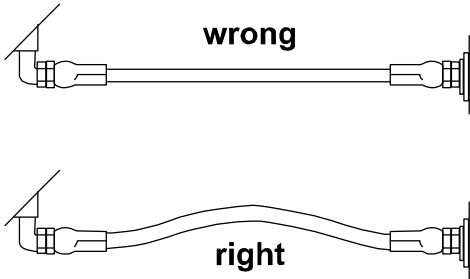
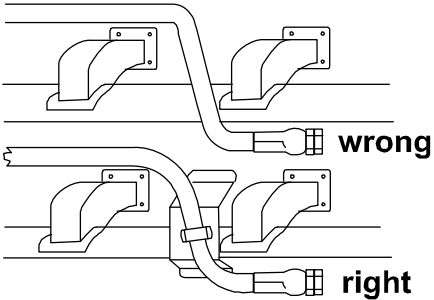
 <p>wrong right</p> <p>1. Hose is weakened when installed in twisted position. Pressure in twisted hose tends to loosen fitting connections. Design so that machine motion produces bending rather than twisting.</p>	 <p>wrong right</p> <p>2. Ample bend radius should be provided to avoid collapsing of line and restriction of flow.</p>
 <p>wrong right</p> <p>3. Exceeding minimum bend radius will greatly reduce hose assembly life.</p>	 <p>wrong right</p> <p>4. Use elbows or other adapters as necessary to eliminate excess hose length and to insure neater installation for easier maintenance.</p>
 <p>wrong right</p> <p>5. When hose assembly is installed in a flexing application, remember that metal hose fittings are not part of the flexible portion. Allow ample free length for flexing.</p>	 <p>wrong right</p> <p>6. When properly routing, use clamps to secure the hose in its proper position.</p>

BLANK PAGE

APPENDIX B: MAINTENANCE AND SERVICE LOG

B.1 GENERAL DESCRIPTION

The maintenance and service log given in this appendix can be used to track and keep a record of the maintenance intervals of the machine, as well as any non-routine repairs or changes made, throughout the productive life of the machine package.

Keeping such a record is extremely beneficial when considering a solution to any troubleshooting problem that might occur. For additional assistance in setting up a routine and orderly schedule to track machine maintenance and repair, refer to **Section 6, Maintenance**, and particularly **Section 6.3, Maintenance Schedule Table**.

For procedure on ordering parts, consult **Section 9, Parts Ordering Procedure, Table 9A - Recommended Spare Parts List**, and **Appendix A, Section A.5, Air N Arc 300 Series All-In-One Power System Available Options List**.

If a part needs to be replaced, but is not listed in any of the above sections, it can readily be identified visually by scanning through the various parts list sections. The various parts list sections identify each part by its individual part number, which in turn can be used to order any part that needs to be replaced.

B.2 MAINTENANCE AND SERVICE LOG

Date of Purchase: _____

BREAK-IN PERIOD SERVICE POINTS

Date Completed: _____

50 HOURS OR TWO MONTHS SERVICE POINTS

Dates Completed: _____

100 HOURS OR FOUR MONTHS SERVICE POINTS

Dates Completed & Parts Replaced: _____

200 HOURS OR EIGHT MONTHS SERVICE POINTS

Dates Completed & Parts Replaced: _____

300 HOURS OR ONE YEAR SERVICE POINTS

Dates Completed & Parts Replaced: _____

600 HOURS OR TWO YEARS SERVICE POINTS

Dates Completed & Parts Replaced: _____

OTHER SERVICE NOTES

B.2 MAINTENANCE AND SERVICE LOG

Date of Purchase: _____

BREAK-IN PERIOD SERVICE POINTS

Date Completed: _____

50 HOURS OR TWO MONTHS SERVICE POINTS

Dates Completed: _____

100 HOURS OR FOUR MONTHS SERVICE POINTS

Dates Completed & Parts Replaced: _____

200 HOURS OR EIGHT MONTHS SERVICE POINTS

Dates Completed & Parts Replaced: _____

300 HOURS OR ONE YEAR SERVICE POINTS

Dates Completed & Parts Replaced: _____

600 HOURS OR TWO YEARS SERVICE POINTS

Dates Completed & Parts Replaced: _____

OTHER SERVICE NOTES

BLANK PAGE

BLANK PAGE



VANAIR®

AIR POWER TO GO™

Vanair Manufacturing, Inc.

10896 West 300 North

Michigan City, IN 46360

Phone: (219) 879-5100

(800) 526-8817

Service Fax: (219) 879-5335

Parts Fax: (219) 879-5340

Sales Fax: (219) 879-5800

www.vanair.com

Printed in the U.S.A.

Specifications Subject to Change
Without Prior Notice